



# HEALTH-CODE

Real operation pem fuel cell HEALTH-state monitoring  
and diagnosis based on DC/DC Converter embedded EIS  
(671486)

Cesare Pianese, Pierpaolo Polverino  
University of Salerno

[pemfc.health-code.eu](http://pemfc.health-code.eu)  
[pianese@unisa.it](mailto:pianese@unisa.it)

*Programme Review Days 2016*  
*Brussels, 21-22 November*

# PROJECT OVERVIEW



## PROJECT INFORMATION

Call topic	FCH-02.3-2014
Topic title	Stationary fuel cell system diagnostics: development of online monitoring and diagnostics systems for reliable and durable fuel cell system operation
G.A. #	671486
Pillar	Energy
Start/End	01/09/15 - 31/12/18
Budget (€)	2,358,736 (100% FCH2JU)
Completion	35% @ M14

## PARTNERS

1. Università degli Studi di Salerno (I);
2. Aalborg Universitet (DK);
3. Ballar Power Europe AS\* (DK);
4. European Institute for Energy Res. (D);
5. Electro Power System S.p.A. (I);
6. Bitron Industrie S.p.A. (I);
7. Université de Franche-Comté (F);
8. Absiskey SAS (F).

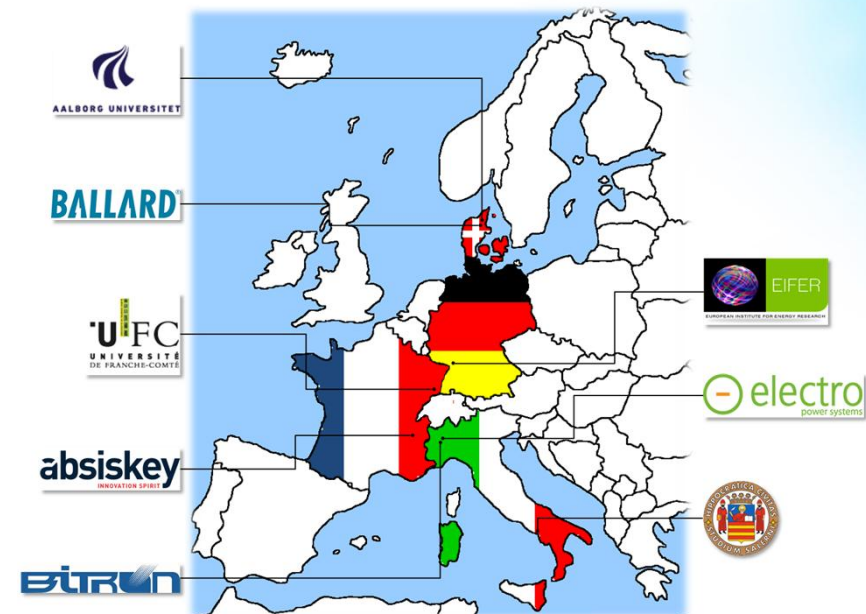

\*Former Dantherm Power A/S.

# PROJECT SUMMARY



HEALTH-CODE aims at implementing an advanced monitoring and diagnostic tool based on Electrochemical Impedance Spectroscopy for air/reformate-fed  $\mu$ -CHP and oxygen/hydrogen-fed backup PEMFCS.

The tool is able to determine FC status (condition monitoring) to support stack failures detection and to infer on the remaining lifetime.

## Embedded low cost on-line EIS



Fault Diagnosis  
&  
Lifetime inference

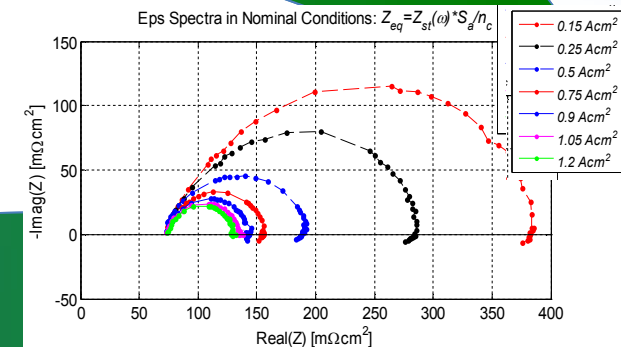
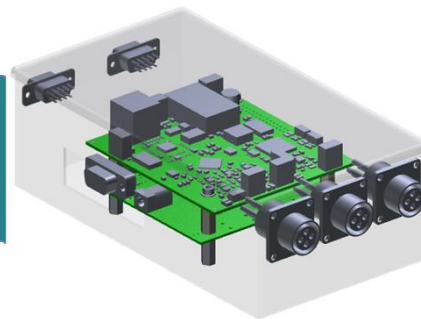

# PROJECT OBJECTIVES



1. Enhancement of **EIS-based diagnosis** for embedded on-line applications;
2. Development of a monitoring and diagnostic tool for **state-of-health assessment, fault detection and isolation** as well as degradation level analysis for **lifetime inference**;
3. EIS-oriented experimental analysis for **5 failure modes**: i) fuel composition, ii) air starvation, iii) fuel starvation, iv) sulphur poisoning, v) flooding & dehydration;
4. **EIS scaling-up** algorithm to reduce **time and costs** of experimental campaign for tool development.

**Performance, Durability, Availability**



**Reduce OPEX**



# D-CODE LEGACY TO HIGHER TRL



## EIS board TRL: 4 → 5/6

The EIS board from D-CODE is re-engineered for high quality measurements and embedded applications, thus moving from lab-scale to system on-line.

## DC/DC converters TRL: 4 → 6

Conventional HW is modified/re-engineered to allow flexibility and multiple market choice for manufacturer strategies.

## Monitoring & diagnostic algorithm TRL: 3 → 4/5

Enhancement for proper isolation of 5 faults and reliability (attention to air-fed and oxygen-fed differences).

## EIS - lab equipment vs. board

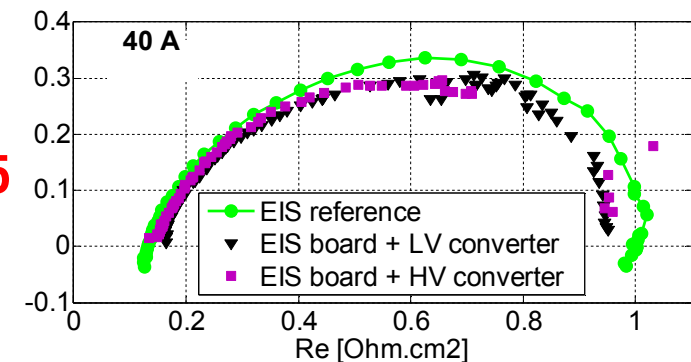
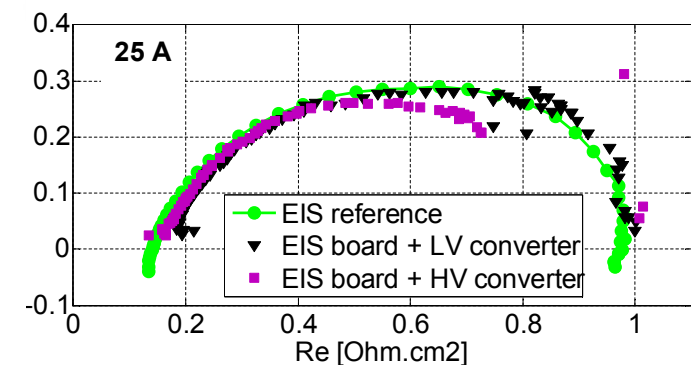

## Ballard Europe $\mu$ -CHP system

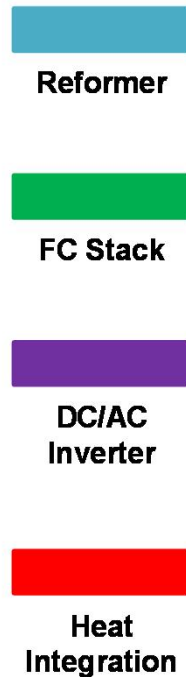
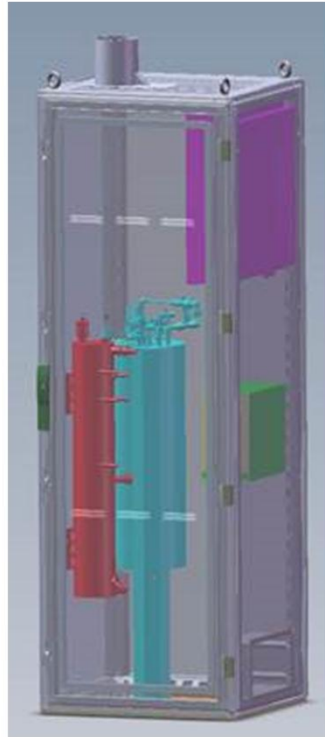

Rated power:

Cooling system:

Reactants:

Applications:

1.3 kW;

Water cooled;

**Air & Reformate;**

Residential heat and electric power production.

## EPS backup system

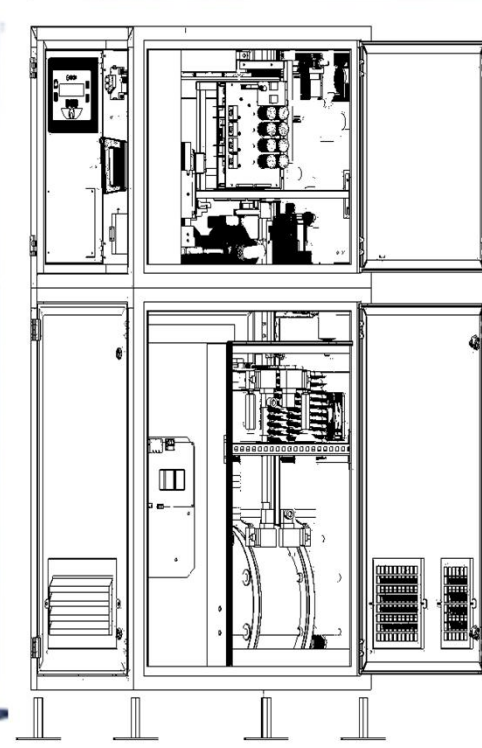

Rated power:

Cooling system:

Reactants:

Applications:

3 kW;

Water cooled;

**Pure Oxygen & Hydrogen;**

Backup/grid-connected electric power production with H<sub>2</sub> as energy buffer.

# ON-LINE EIS

## MONITORING, DIAGNOSTICS, LIFETIME

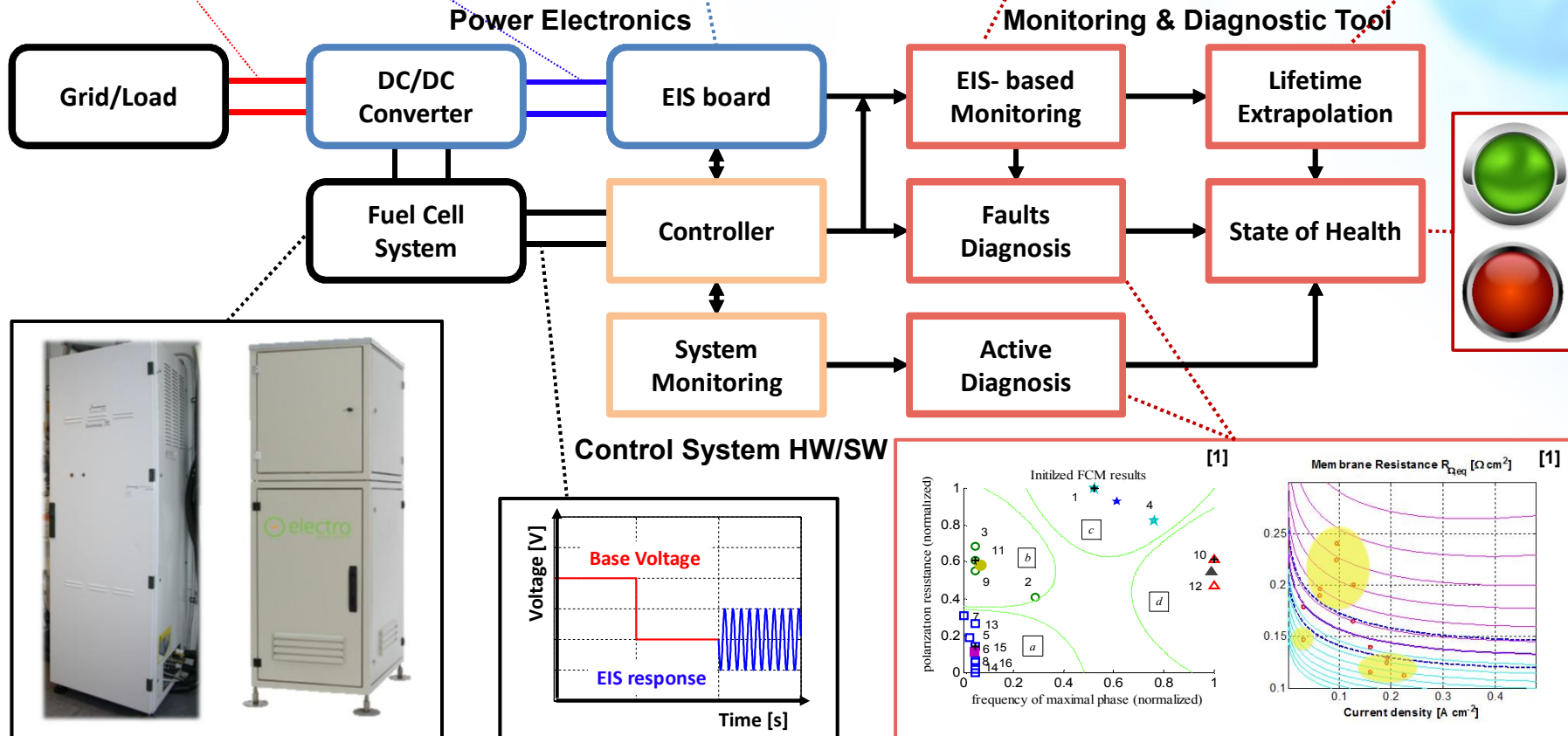
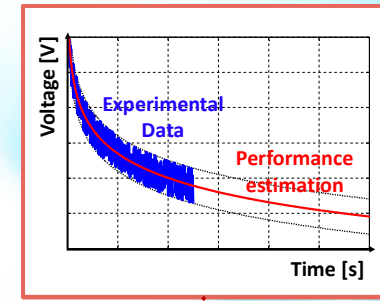
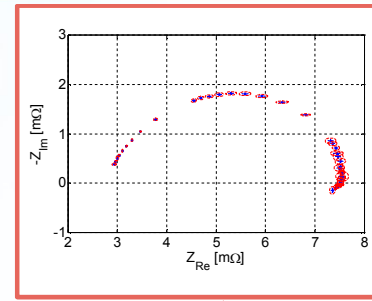
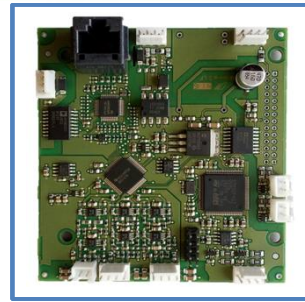
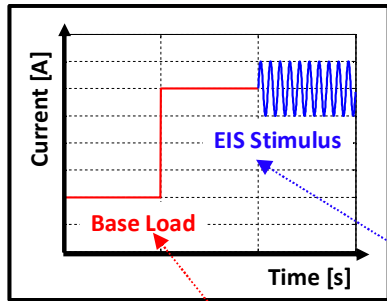

[1] D-CODE Project final report: [www.d-code-jti.eu](http://www.d-code-jti.eu)

# PROJECT FRAMEWORK

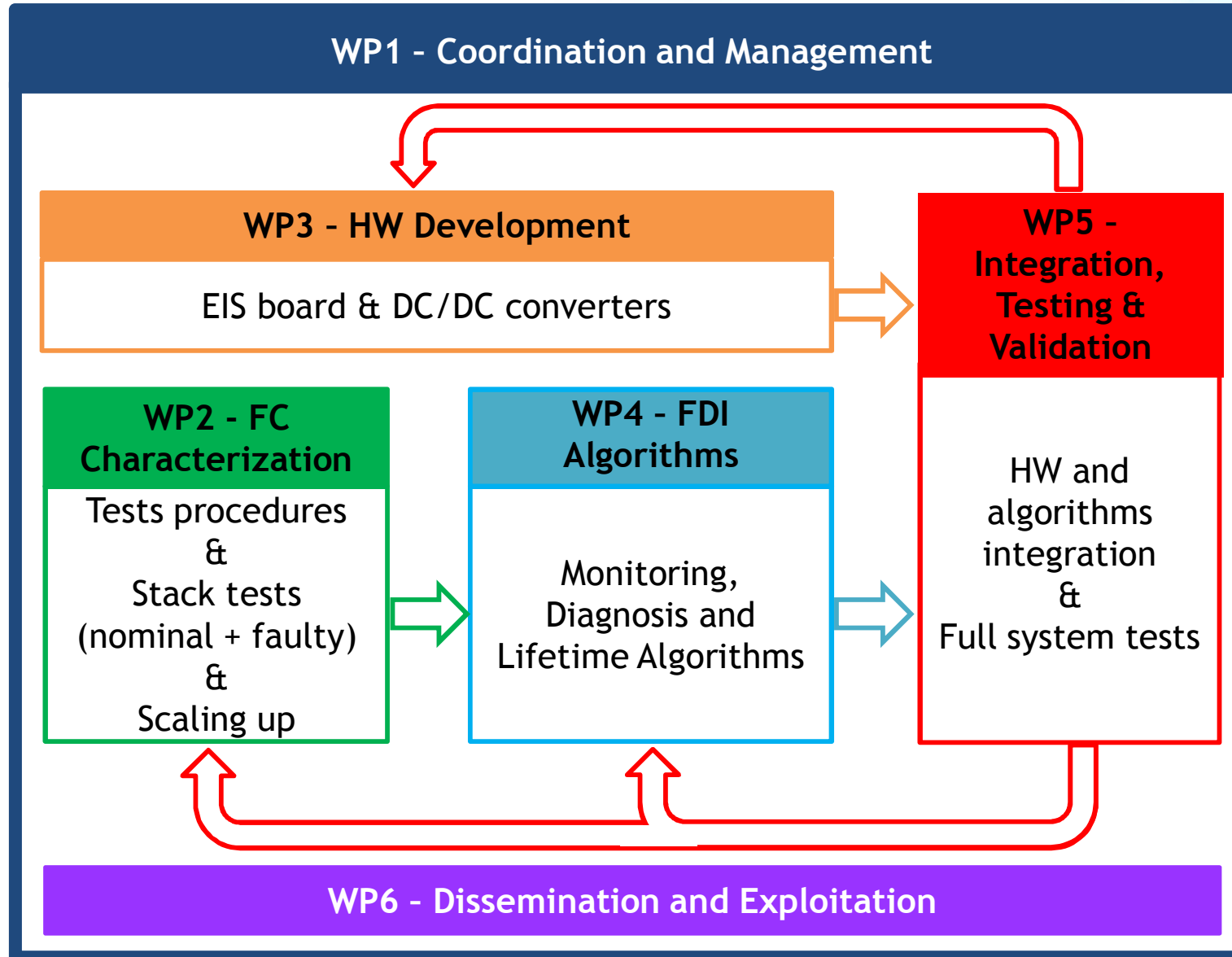

# EIS BOARD

FROM D-CODE  
(slave)



TO HEALTH-CODE

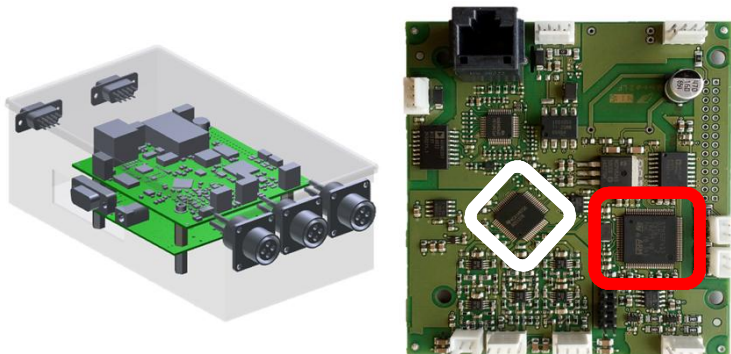

BOARD FUNCTIONS	D-CODE	HEALTH-CODE
Voltage input	✓	✓
Current sensor input	✓	✓
Current shunt input	✗	✓
Analog filtering	✗	✓
ADC 24 bit	✓	✓
PWM from Beagle Board	✓	✓
Real Time microprocessor	✗	✓
Aux SRAM	✗	✓
PWM from RT micro	✗	✓
ISO CAN interface	✗	✓
ISO COM interface	✗	✓
100Tbase ETH interface	✗	✓
ADC clock tunable	✗	✓
ADC SW configurable	✗	✓

- One DC/DC power for each tested FC system is considered (i.e. Ballard Power EU  $\mu$ -CHP system and EPS backup system);
- This work will lead to **useful guidelines** for any company who would like to **implement the EIS board** on its own FC system:
  1. design a new new DC/DC converter for EIS board interfacing;
  2. modify an available one to allow the communication with the EIS board.

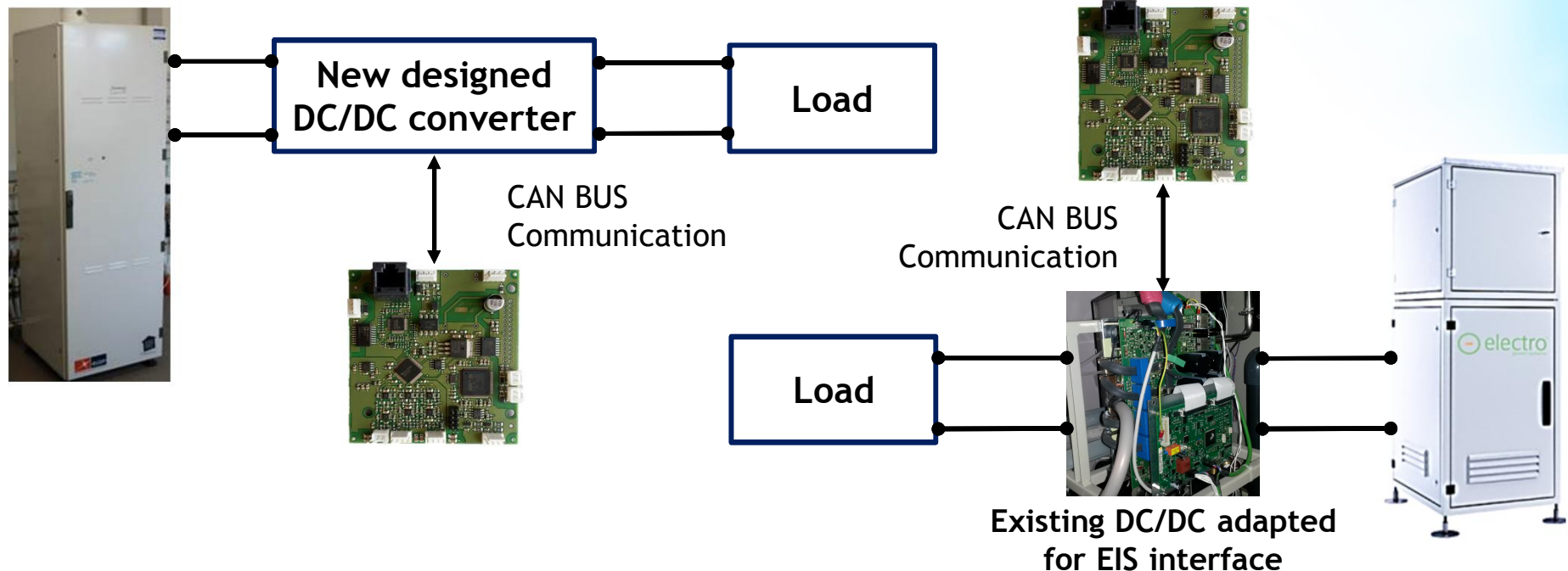

# EXPERIMENTS



EPS short stack @ UFC

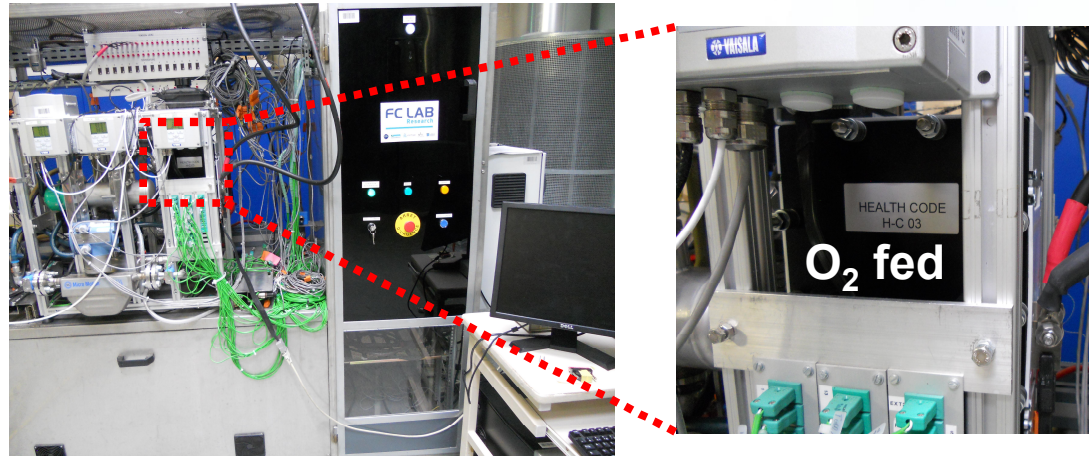

Overall expected number of EIS spectra between **1000** and **1500** Under nominal and faulty operations

Ballard stack @ AAU

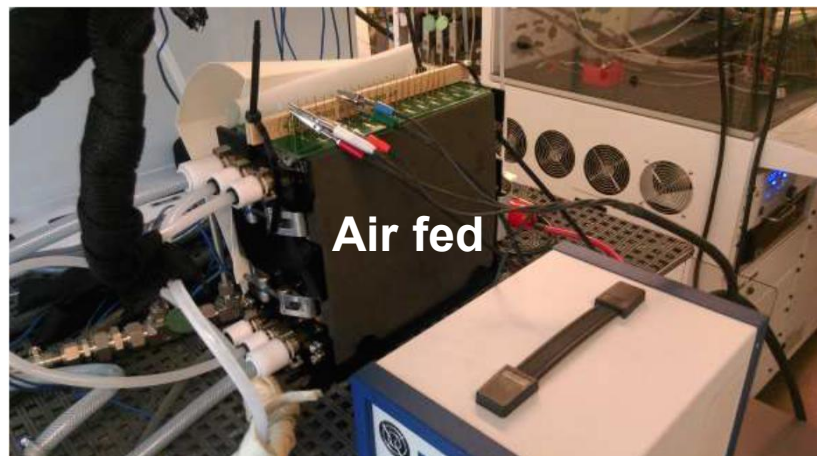

Ballard stack @ EIFER

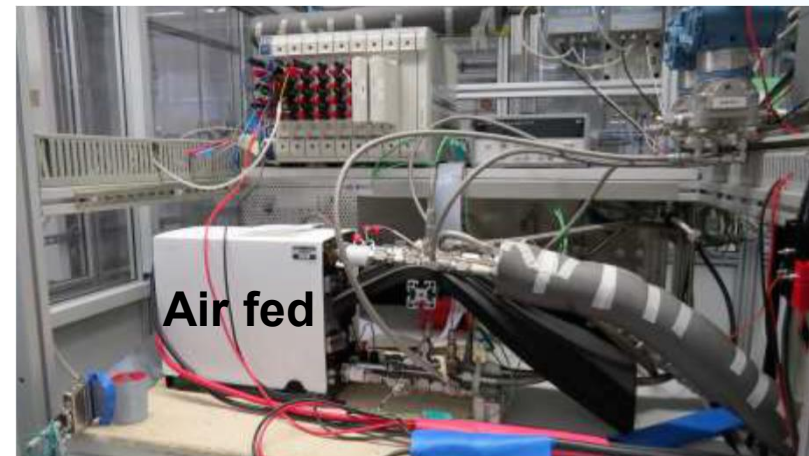

# EIS CHARACTERIZATION

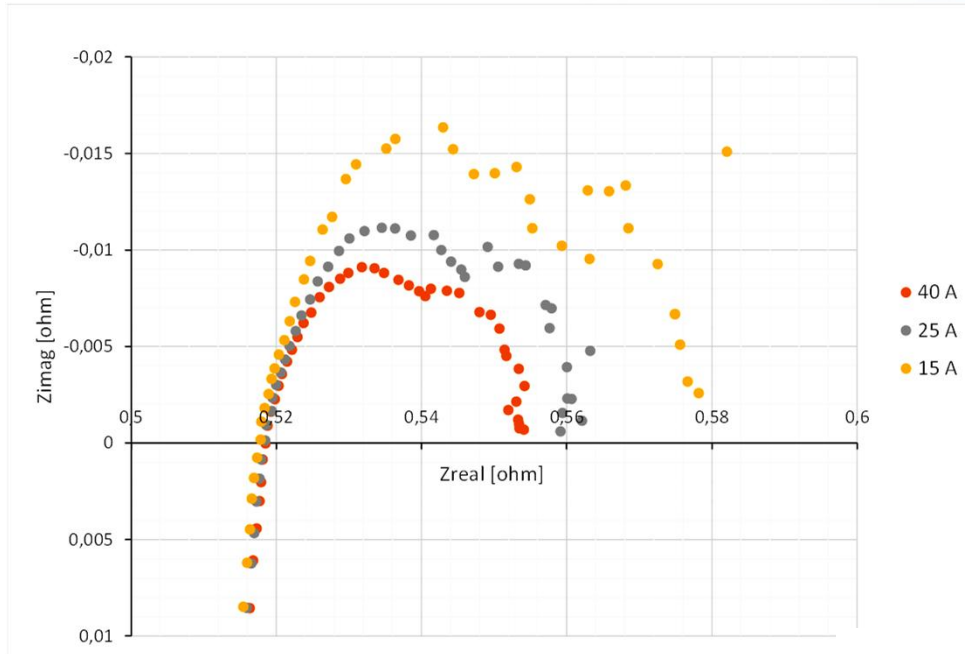

**Preliminary EIS results @ AAU**  
 Tests done on **air/reformed-fed** stack in nominal conditions @ 15 A, 25 A and 40 A.

**About 160 spectra measured to date, 110 of which in faulty conditions.**

**Preliminary EIS results @ UFC**  
 Tests done on **oxygen/hydrogen-fed** short stack in nominal conditions.

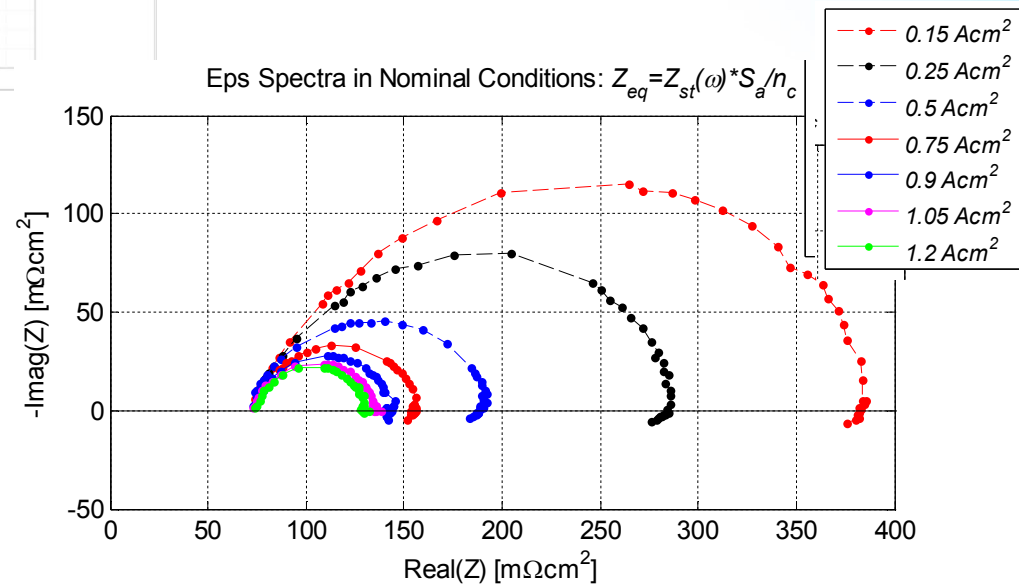

- Reduce fuel cells (FCs) testing costs providing a scaling-up algorithm able to extrapolate full stack performance and impedance behavior from single cell and/or short stack (i.e. single repeated unit - SRU) data;
- Derive **stack faulty behavior** from single cell tests performed under faulty conditions to improve FC systems lifetime.

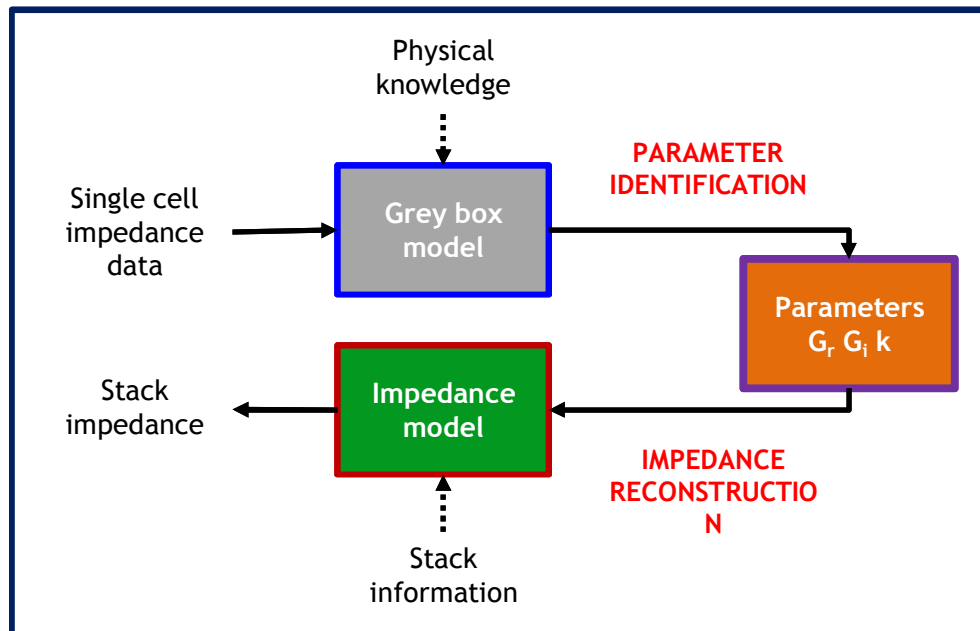

## PRELIMINARY TEST ON D-CODE DATA

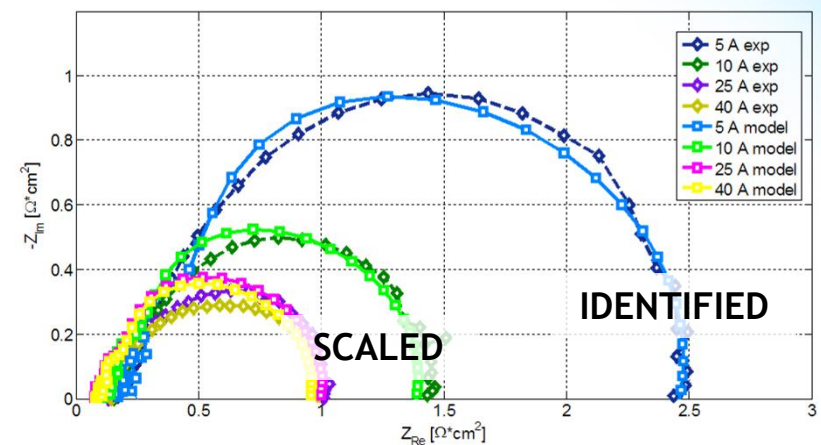

# DIAGNOSTIC ALGORITHMS



## FRAMEWORK FROM D-CODE

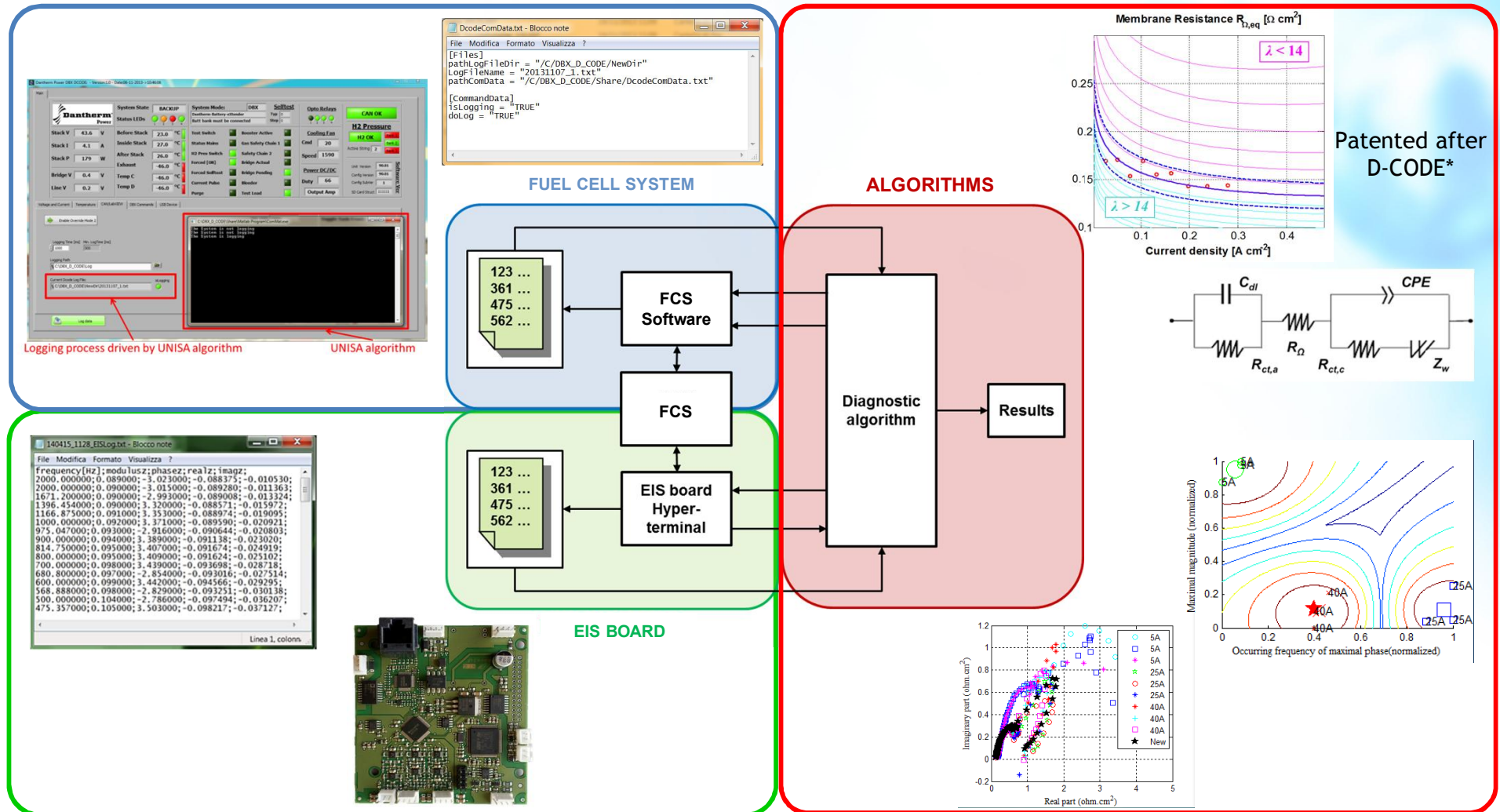

\*Patent, No. PCT/IB2015/058258; Authors: Petrone R., Polverino P., Pianese C., Sorrentino M.; Title: Method For Monitoring And Diagnosing Electrochemical Devices Based On Automatic Electrochemical Impedance Identification.

## MAIN OBJECTIVE

Upon analysis of experimental data, **EIS parameters** not changing with faulty conditions at different currents **are identified**: their variation can thus be only related to **ageing phenomena**.

## EXAMPLE

**Phase shift** of the Bode Plot **at high frequencies**:

- small double standard deviation for all experiments, minor influence of faulty conditions;
- phase shift over time may be related to ageing.

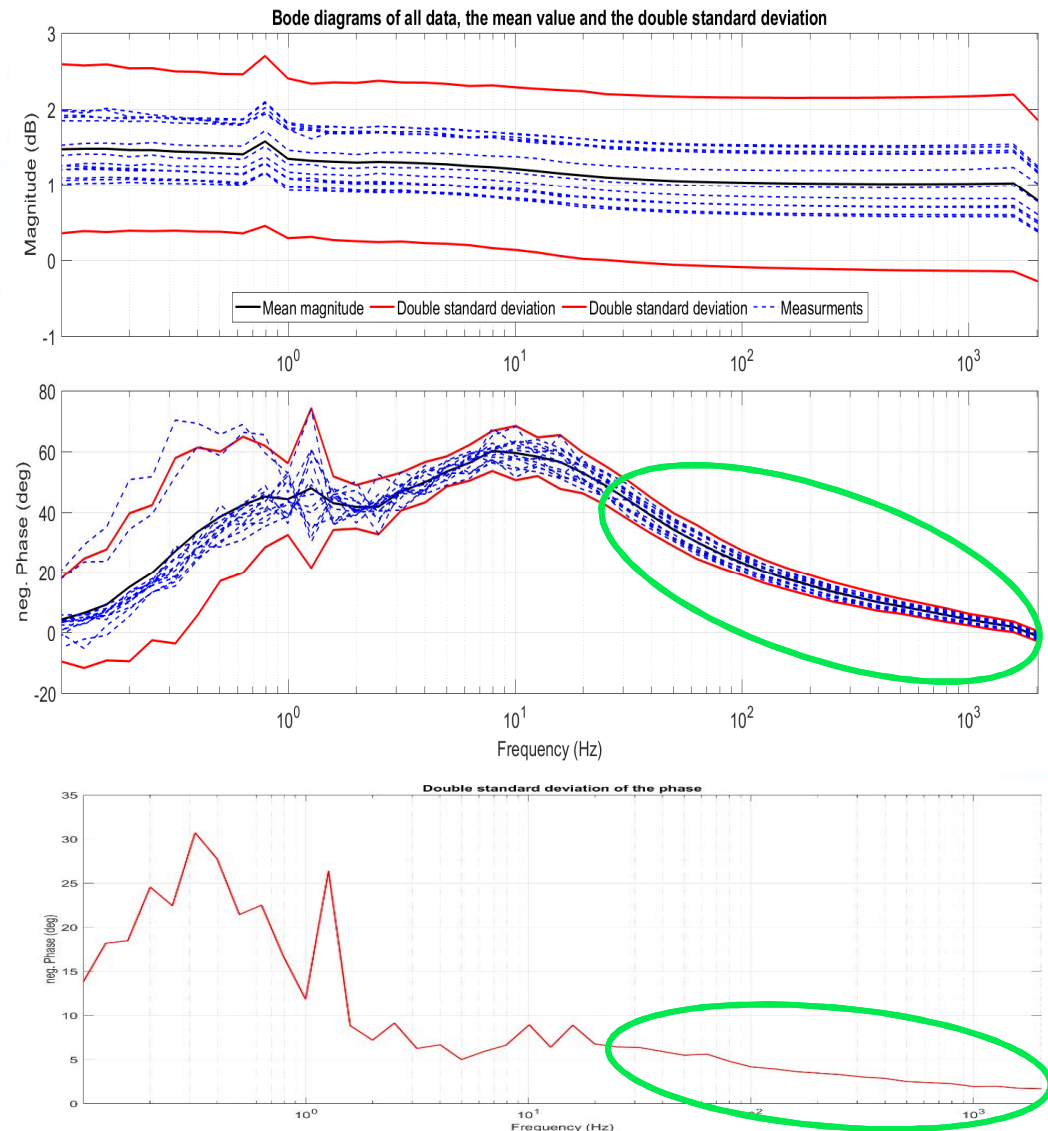

# SYNERGIES WITH OTHER PROJECTS



## Interactions with projects funded under EU programmes (FP7)

<i>D-CODE</i>	Leverage of EIS board and power electronics hardware, as well as monitoring and diagnostic algorithms.
<i>GENIUS</i>	Application of Design of Experiment (DoE) approach, monitoring and diagnostic algorithms and Fault Tree Analysis.
<i>FITUP</i>	On-field tests of UPS systems to improve backup system reliability.
<i>STACK-TEST</i>	Harmonized test procedures for PEMFC stack under normal and faulty conditions.
<i>DIAMOND</i>	Modelling for control and diagnosis, fault tree analysis, advanced control, experiments.
<i>SAPPHIRE</i>	Control, diagnosis and prognosis of CHP PEM fuel cell systems.

## Interactions with national and international-level projects and initiatives

<i>PROCIPE (F)</i>	Prognosis of automotive and stationary PEM FC.
<i>DIAPASON 1&amp;2 (F)</i>	Diagnostic methodologies, experiment in abnormal conditions, degradation mechanisms.
<i>EXC-CELL (DK)</i>	New generation of control algorithm with built-in diagnostics capabilities to improve operation.

# PROJECT PROGRESS



- Experiments
- EIS Board
- DC/DC converters
- Diagnostic algorithms
- Scaling-up algorithm

Start M0



End M40

## Activities completion

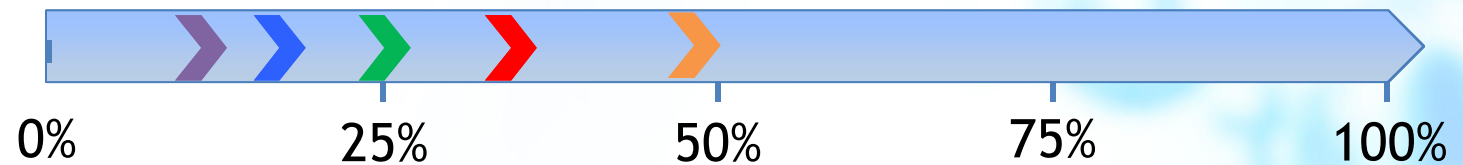

## Future steps towards Mid-Term (M20):

**Experiments:** 1<sup>st</sup> experimental campaign in unfaulty and faulty conditions is ongoing (data available @ M16); 2<sup>nd</sup> experimental campaign is scheduled (to be closed @ M24).

**EIS board:** first EIS board new generation prototype (available @ M14); preliminary tests are scheduled before M18.

**DC/DC converters:** EPS converter modifications ongoing (available @ M17); Ballard new converter designed, to be commissioned (prototype available @ M21).

**Diagnostic algorithms:** will be tested on the EIS measurements once first campaign is completed (after M16).

**Scaling-up algorithm:** characterized on literature data (M12) to be finalized and validated on project data (after M16).

## Exploitation

- Enhance **educational** activities in FCH (introduce control and diagnostic topics at BS & MS levels; strengthen PhD programs).
- Secure potentially **patentable** findings.
- Apply EIS-based monitoring for **control** of FCs
- Extend the methods to related fields (**other FCs** or technologies).
- Possible **spin-off** activities supported by national and EU programs.

## Impact

- **Lifetime** from B10-5 to B10-10\*.
- **Efficiency** from 32 to 36%;
- **Availability** from 99.6% to 99.9% and warranty condition from 15000 h/1000 cycles to 20000 h/1500 cycles.
- Establish structured research activities focusing on applied research topics.
- Build new collaboration with other industrial suppliers/partners.
- Increase know-how and potentially patent portfolio.

# DISSEMINATION ACTIVITIES



## Public deliverables OGY(F)26

- D5.1 System Testing Procedure
- D5.3 Diagnostic Tool Final Validation
- D6.1 Project Website
- D6.6 Workshop N.1
- D6.7 Final Demonstration Workshop N.2

## Conferences/Workshops MC(F)80

- Upcoming workshop to be organised jointly with DIAMOND project @ M23 (Summer 2017)

## Social media MC(F)64

[pemfc.health-code.eu](http://pemfc.health-code.eu)



## Next publications: MC(F)67

- 2 papers on fault analysis and diagnostic algorithms based on electrochemical impedance spectroscopy (EIS) are currently under preparation.
- 1 paper on scaling-up approach under preparation.

MC(F)63

## Patents:

- Algorithms and hardware development may lead to IP protection actions.

## Slide 19

---

- OGY(F)26** Indicate the full name of up to 5 public deliverables  
ORTEGA GARCIA Yanaris ( FCH ), 16/02/2016
- MC(F)63** Specify the number of patents and give reference to up to 2  
MARENCO Claudia ( FCH ), 16/02/2016
- MC(F)67** Specify the number of publications and give reference up to 2 most relevant ones  
MARENCO Claudia ( FCH ), 22/02/2016
- MC(F)64** Project presence on social media:  
Create a hyperlink to the relevant project page (Youtube, LinkedIn, Facebook, Twitter, Instagram). Delete the icons that are irrelevant because the project is not present on the social media concerned.  
To create a hyperlink: right click on the icon, select "hyperlink" and paste the url in the "address" field  
MARENCO Claudia ( FCH ), 08/09/2016
- MC(F)80** Indicate the number of conferences/workshops organised by the project and that the project has attended  
MARENCO Claudia ( FCH ), 08/09/2016

# Thank You!

Coordinator: Cesare Pianese  
pianese@unisa.it  
pemfc.health-code.eu