



***"Next Generation PEM Electrolyser for Sustainable
Hydrogen Production"***

Contract no. 245262

*Dr. Magnus S Thomassen
SINTEF Materials and Chemistry
Trondheim, Norway*

*FCH Review day 2011
Brussels, 22 November*

NEXPEL main objectives:

- Develop and demonstrate a PEM water electrolyser integrated with Renewable Energy Sources (RES):
- 75% Efficiency (LHV), H₂ production cost ~ €5,000 / Nm³h⁻¹, target lifetime of 40,000 h

Jan 2010 - Dec 2012

Total Budget: € 3,353,549

www.nexpel.eu



Overview NEXPEL consortium



Approach

WP2 New membrane materials

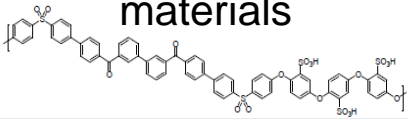

WP3 New catalysts

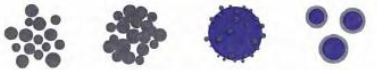

WP7 Improved DC-DC converter

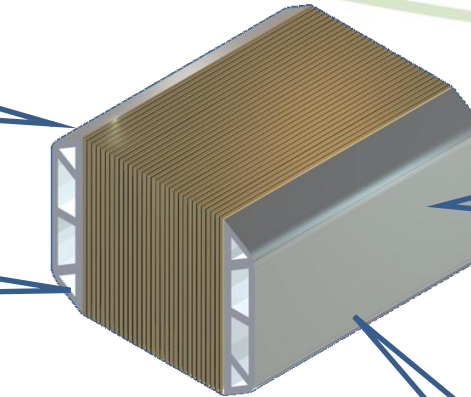
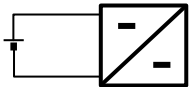

WP4 Improved MEAs

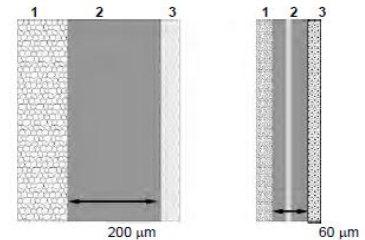

WP7 Integration with RES



WP5&6 Novel stack design and new construction materials

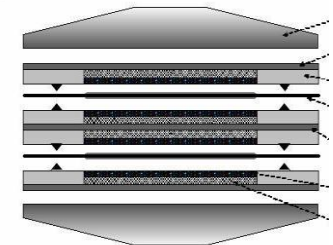

Approach NEXPEL milestones

Month/Year	Milestone	Status
Mar-2010	Milestone 1: Kick-off meeting	Achieved
Dec-2010	Milestone 2: Key parameters for design and operation of NEXPEL stack determined.	Achieved
Aug-2011	Milestone 3: Novel MEA demonstrated using low cost membrane and reduced noble metal loadings	Delayed
Feb-2012	Milestone 4: PEM electrolysis short stack assembled and function tested	
Jun-2012	Milestones 5&6: PEM stack and DC/DC converter integrated in test site for demonstration with RES	

Novel membrane and catalyst materials

- A series of polyaromatic materials has been prepared
 - Proton conductivity of $> 40 \text{ mS cm}^{-2}$ (Nafion $\sim 100 \text{ mS cm}^{-2}$)
 - High mechanical stability ($> 120 \text{ }^\circ\text{C}$)
 - 10g scale of ionomers produced
 - 5.5 m^2 membrane cast on continuous production line.
- Highly active oxygen evolution catalysts developed
 - 2 nm Ir particles on Antimony Tin Oxide support (20wt% Ir)
 - 0.94 Acm^{-2} at 1.65 V and $80 \text{ }^\circ\text{C}$
(250% mass activity vs. state of the art)
 - Scaled up synthesis (8g catalyst batch size)

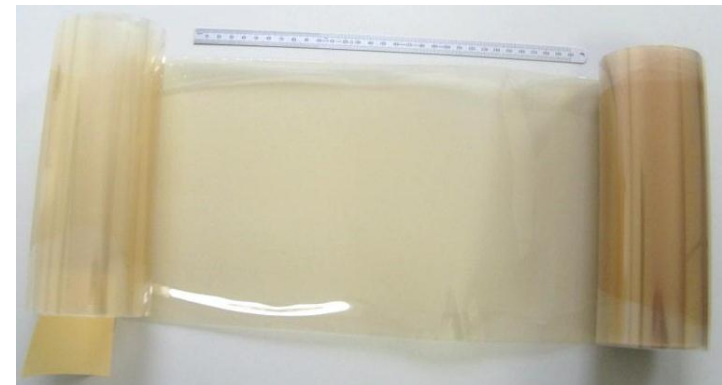
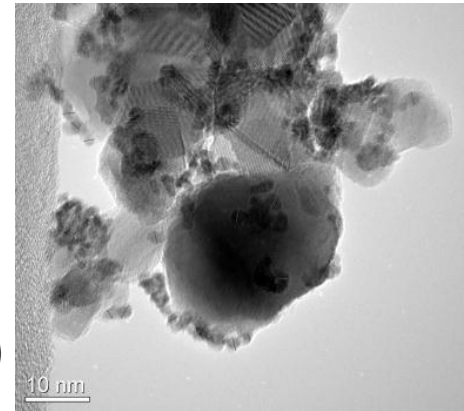

MEAs, bipolar plates and current collectors

- MEA/CCM development using novel membranes and catalysts on-going
 - Optimisation of electrode composition and morphology
 - Evaluation of production methods
- Bipolar plates
 - Wide bibliographic review performed
 - Several Ti grades and stainless steels evaluated in PEMWE representative conditions (several 100h)
- Current collectors
 - Several porous Ti-materials have been tested as current collectors
 - First generation prototype constructed in June 2011.
 - Significant potential for cost reduction identified

Stack & system design, market analysis and cost studies

- A stack design for high pressure operation established
 - New sealing concepts
 - Optimisation of fluid pressure drop and thermal management
 - First 2-cell short stack under construction
- Initial system design studies completed
 - Detailed flow-sheets of PEM electrolysis plants of 10 and 100 Nm³ h⁻¹
 - Cost and performance studies as a function of electrolyser pressure
 - Risk assessments and safety analysis
- Cost and market analysis
 - NEXPEL stack can reach target costs with production volumes > 100 units.

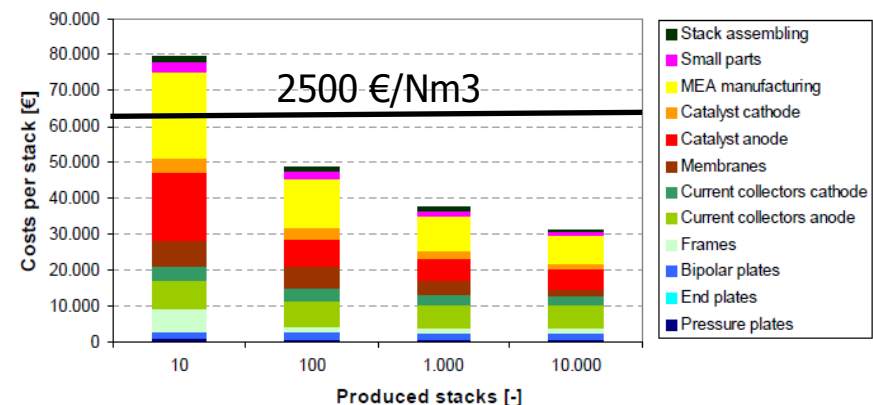

2. Alignment to MAIP

- Strategic targets
- Technical targets addressed
- Technical targets not addressed

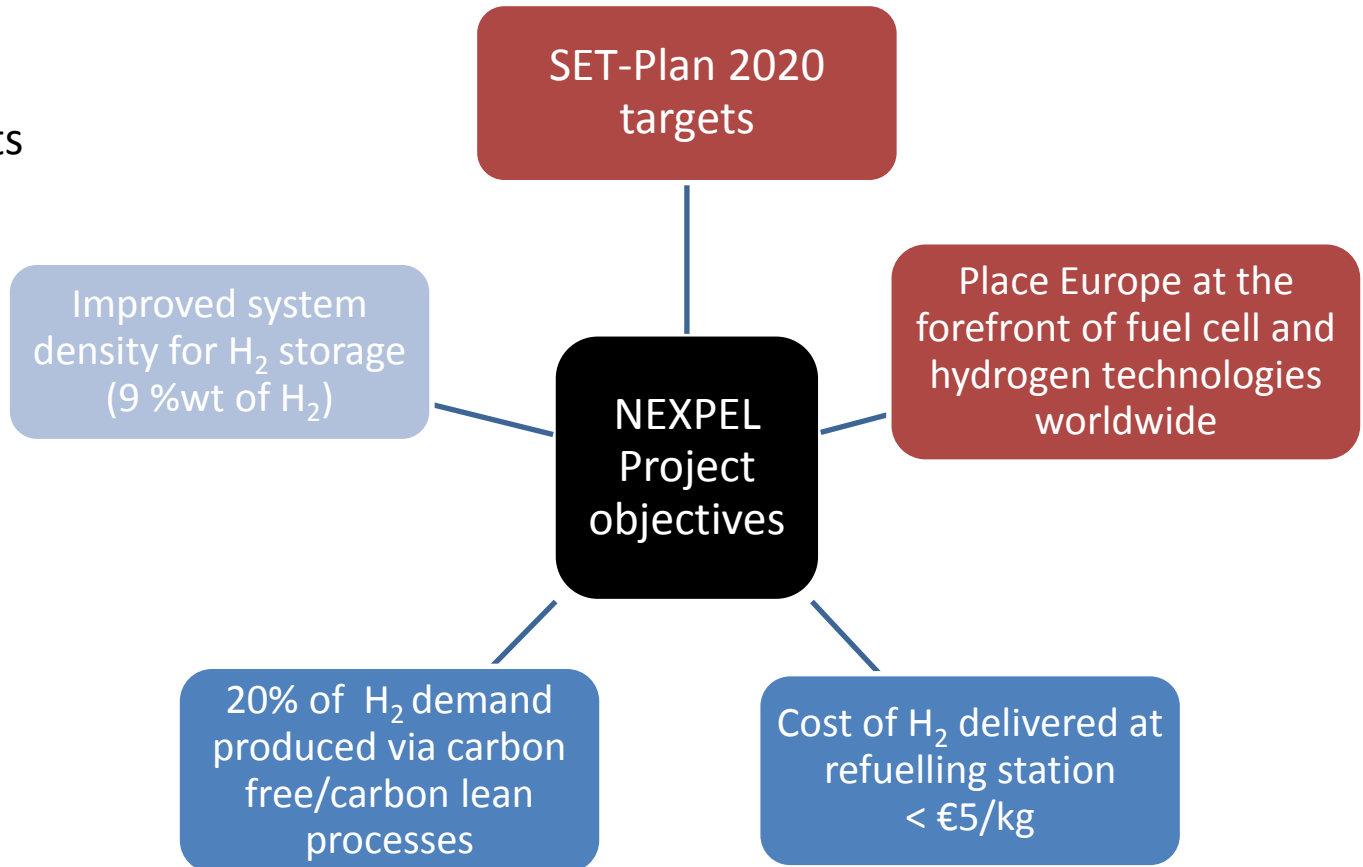

2. Alignment to MAIP

Hydrogen production and distribution

"Accordingly, the main emphasis of this application area will be on **research and development of mature production and storage technologies and on breakthrough orientated research of longer term, fully sustainable hydrogen production and supply pathways**. The mature production technologies include (i) reforming (and gas purification) based on bio-fuels as well as conventional fuels; **(ii) cost-efficient low-temperature electrolysers adapted for the large-scale use of carbon free electricity** and (iii) biomass to hydrogen (BTH) thermal conversion.

2. Alignment to AIP2008: Project activities and results

Theme 2.1: Efficient PEM electrolyzers

Theme 2.1 project objectives	NEXPEL activities/results match
Research to increase electrode stability and efficiency, development of new catalyst and materials for lowering costs and improved performance;	Yes , improved catalysts with 250% mass activity vs. state of the art demonstrated
Research and development on advanced power electronics	Yes , DC/DC converter with 98% efficiency under construction
Research to improve materials/components/systems durability/reliability, robustness in order to reduce costs while optimizing production technologies through design optimization	Yes , Materials research on catalysts and membranes. Stack design for reduced production costs
Development of low cost, high efficient electrolyser system operating at high pressure (10MPa = 100bar)	Yes , Stack design for reduced costs and high pressure operation (50 bar)
Setting up of field demonstration projects and trials on integration of electrolyser with RES. The work needs to include evaluation of system integration with RES through improvements in modelling tools	Yes , Electrolyser will be integrated with wind and solar power. Modelling of RES integration.

3. Cross-cutting issues

NEXPEL contributes to

- Training and Education
 - At least 5 Master students have received training within the project
- Safety, Regulations, Codes and Standards
 - Comprehensive Risk assesment and safety analysis of system and stack design performed as part of NEXPEL project .
 - Field test of NEXPEL electrolyser respect safety regulations on hydrogen filling station site
- Dissemination & public awareness
 - Project achievements will be disseminated by publication in international journals , conferences & workshops, press releases, and via www.nexpel.eu
 - 4 Oral Presentations at international conferences and 1 peer-reviewed paper published.

3. Cross-cutting issues

Dissemination & public awareness

- An international electrolysis workshop will be organized on May 10-11, 2012 in Copenhagen

Content:

- *Technical overview – International Initiatives*
- *The challenge: Stationary energy storage and energy for transportation*
- *The solution: Hydrogen production by electrolysis*
- *Technical poster presentations*

Organized by:

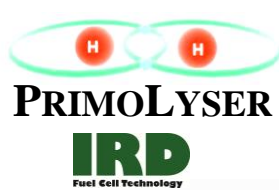

National Danish funded projects:
Medlys (FI 10-093906)
HyProvide the PEM track (EUDP)
Next Generation Alkaline Electrolysis (HT)

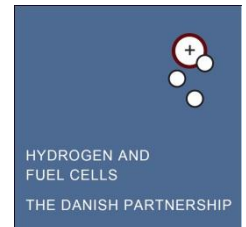

4. Enhancing cooperation and future perspectives

- Technology Transfer / Collaborations
 - NEXPEL interacts with several national projects where NEXPEL consortium partners are contributing.
 - Transfer of generic competence (e.g. component testing protocols, safety considerations, etc.)
 - Interfacing with organisations
 - National hydrogen associations; Norwegian Hydrogen Association and NOW
 - IEA Hydrogen Implementation Agreement – Task 24
 - Wind Energy and Hydrogen Integration

4. Enhancing cooperation and future perspectives

- Project Future Perspectives
 - Proposed a continuation of the project in FCH-JU 2011 call.
 - Further development of most promising results
 - Degradation and lifetime issues of PEM electrolyzers
 - Two patent applications are being considered
 - Securing IPR for further development / commercialisation
- Need/opportunity for increased cooperation/research
 - Demonstration of cost reduction potential
 - Large scale manufacturing / up-scaling of novel material synthesis
 - Degradation and lifetime issues

Thank you for your attention



www.nexpel.eu