



JRC VALIDATED METHODS, REFERENCE METHODS AND MEASUREMENTS REPORT

EU harmonised accelerated stress testing protocols for low-temperature water electrolyser

A proposal for assessing performance degradation in water electrolyser stacks

Malkow, T., Pilenga, A.

2024



This publication is a Validated Methods, Reference Methods and Measurements report by the Joint Research Centre (JRC), the European Commission's science and knowledge service. It aims to provide evidence-based scientific support to the European policymaking process. The contents of this publication do not necessarily reflect the position or opinion of the European Commission. Neither the European Commission nor any person acting on behalf of the Commission is responsible for the use that might be made of this publication. For information on the methodology and quality underlying the data used in this publication for which the source is neither Eurostat nor other Commission services, users should contact the referenced source. The designations employed and the presentation of material on the maps do not imply the expression of any opinion whatsoever on the part of the European Union concerning the legal status of any country, territory, city or area or of its authorities, or concerning the delimitation of its frontiers or boundaries.

Contact information

Name: Thomas Malkow

Address: European Commission, Joint Research Centre, Westerduinweg 3, 1755 LE Petten, The Netherlands

Email: Thomas.Malkow@ec.europa.eu

Tel.: +31 224 56 56 56

EU Science Hub

<https://joint-research-centre.ec.europa.eu>

JRC133726

EUR 31748 EN

PDF	ISBN 978-92-68-09646-8	ISSN 1831-9424	doi:10.2760/988717	KJ-NA-31-748-EN-N
Print	ISBN 978-92-68-09647-5	ISSN 1018-5593	doi:10.2760/79843	KJ-NA-31-748-EN-C

Luxembourg: Publications Office of the European Union, 2024

© European Union, 2024



The reuse policy of the European Commission documents is implemented by the Commission Decision 2011/833/EU of 12 December 2011 on the reuse of Commission documents (OJ L 330, 14.12.2011, p. 39). Unless otherwise noted, the reuse of this document is authorised under the Creative Commons Attribution 4.0 International (CC BY 4.0) licence (<https://creativecommons.org/licenses/by/4.0/>). This means that reuse is allowed provided appropriate credit is given and any changes are indicated.

For any use or reproduction of photos or other material that is not owned by the European Union, permission must be sought directly from the copyright holders. The European Union does not own the copyright in relation to the following elements:

- page 3, accelera by Cummins logo, source: <https://www.accelerazero.com>,
- page 3, CEA logo, source: <https://www.cea.fr>,
- page 3, Chemours logo, source: <https://www.chemours.com>,
- page 3, CNR logo, source: <https://www.cnr.it>,
- page 3, DLR logo, source: <https://www.dlr.de>,
- page 4, Elogen logo, source: <https://elogenh2.com>,
- page 4, Fraunhofer ICT logo, source: <https://www.ict.fraunhofer.de>,
- page 4, FHa logo, source: <https://hidrogenoaragon.org>,
- page 4, ITM Power logo, source: <https://itm-power.com>,
- page 4, Johnson Matthey logo, source: <https://matthey.com>,
- page 4, ProPuls logo, source: <https://www.propuls.de>,
- page 4, Schaeffler logo, source: <https://www.schaffler.com>
- page 4, Shell logo, source: <https://www.shell.com>,
- page 4, SINTEF logo, source: <https://www.sintef.no>,
- page 4, TNO logo, source: <https://www.tno.nl>,
- page 4, TU/e logo, source: <https://www.tue.nl> and
- page 4, TUG logo, source: <https://www.tugraz.at>.

How to cite this report: Malkow, T., Pilenga, A.; *EU harmonised accelerated stress testing protocols for low-temperature water electrolyser*; Publications Office of the European Union, Luxembourg, 2024; doi:10.2760/988717; JRC133726.

Contents

1		
2	Abstract.....	1
3	Foreword.....	2
4	Acknowledgements.....	3
5	1 Introduction.....	5
6	2 Objective and scope of this document.....	7
7	3 Overview of low-temperature water electrolysis technologies.....	9
8	3.1 WEL electrode reactions.....	9
9	3.2 Materials, operating conditions and technology readiness levels.....	10
10	3.3 Stack operation modes.....	10
11	3.4 Advantages, disadvantages and challenges.....	11
12	4 Terminology.....	13
13	4.1 General.....	13
14	4.2 Terms and definitions.....	13
15	4.3 Abbreviations and acronyms used.....	21
16	4.4 Symbols used.....	21
17	5 Description of test items.....	22
18	5.1 AWE stack.....	22
19	5.2 AEMWE stack.....	23
20	5.3 PEMWE stack.....	24
21	6 Proposal for AST protocols.....	26
22	6.1 General.....	26
23	6.2 Measurement techniques.....	27
24	6.3 Test conditions.....	27
25	6.4 Reference test conditions.....	27
26	6.5 Stressing operating conditions.....	28
27	6.6 Test plan.....	29
28	6.7 Performance tests.....	30
29	6.7.1 Input electric power.....	30
30	6.7.2 Input direct current.....	30
31	6.7.3 Input DC voltage.....	30
32	6.7.4 Input thermal power.....	30
33	6.7.5 Input power of compression.....	30
34	6.7.6 Response time and ramp energy.....	30
35	6.7.7 Measurements of fluid feeds.....	31
36	6.7.8 Hydrogen output rate and quality.....	31
37	6.7.9 Oxygen output rate and concentration.....	31
38	6.7.10 Water quality measurements.....	31
39	6.7.11 Polarisation curve measurements.....	32
40	6.7.12 EIS measurements.....	34

41	6.7.13 Efficiency determination	37
42	6.8 Operation profiles	38
43	6.8.1 General.....	38
44	6.8.2 Graphical representation.....	38
45	6.9 Durability tests.....	47
46	6.9.1 General.....	47
47	6.9.2 Constant stack operation.....	47
48	6.9.3 Variable stack operation.....	47
49	6.10 Determination of KPIs.....	47
50	7 Presentation of test results	51
51	8 Conclusions with final remarks.....	53
52	References.....	54
53	List of Abbreviations and Acronyms	65
54	List of Symbols	69
55	List of Figures.....	74
56	List of Tables.....	75
57	Annexes.....	76
58	Annex A Test safety.....	76
59	Annex B Test report.....	77
60	B.1 General.....	77
61	B.2 Title page	77
62	B.3 Summary.....	77

63 **Abstract**

64 This document proposes accelerated stress testing (AST) protocols for assessing the performance degradation
65 of low-temperature water electrolyser (LTWE) stacks. Water electrolyser (WE) stacks generate bulk amount of
66 clean hydrogen by the electrolysis of water using electricity mainly from renewable energy sources (RESs).

67 By applying these protocols, it is generally possible to evaluate the performance degradation of different
68 stacks. It is then possible to adequately compare the three low-temperature water electrolysis (LTWEL) technolo-
69 gies, namely alkaline water electrolysis (AEL) in an alkaline water electrolyser (AWE), anion exchange membrane
70 water electrolysis (AEMEL) in an anion exchange polymer membrane water electrolyser (AEMWE) and proton
71 exchange membrane water electrolysis (PEMEL) in a proton exchange polymer membrane water electrolyser
72 (PEMWE).

73 These protocols are to be used by the research community and industry alike. For example, to evaluate
74 research and development (R&D) progress, set research and innovation (R&I) priorities with the inclusion of cost
75 targets, development milestones, and technological benchmarks while also making informed decisions regarding
76 technology selection.

77 Foreword

78 This report was prepared under the framework contract between the Directorate-General JRC of the European
79 Commission (EC) and the Clean Hydrogen Joint Undertaking (Clean H₂ JU), the successor to the Fuel Cells and
80 Hydrogen second Joint Undertaking (FCH2JU) ⁽¹⁾. The JRC contractual activities are stated in the strategic re-
81 search and innovation agenda 2021-2027 of the Clean Hydrogen Partnership for Europe (SRIA) ⁽²⁾. This report
82 constitutes part two of the deliverable B.1 entitled "Report summarising the workshop findings on electrolyser
83 lifetime degradation phenomena SoA and a preliminary proposal for setting up harmonised protocols for ac-
84 celerated stress testing of low temperature electrolysers" of the Rolling Plan 2023 contained in the Clean H₂
85 JU work programme 2023 ⁽³⁾. It is the result of a collaborative effort between partners from research and
86 technology organisations (RTOs) in industry and academia participating to European Union (EU) funded R&D
87 projects ⁽⁴⁾ in power-to-hydrogen (P-to-H₂) and hydrogen-to-industry (H₂-to-I) applications involving LTWE for
88 demonstration and eventually, industrial deployment.
89



90

⁽¹⁾ According to Article 3(1)(c) of Council Regulation (EU) No 2021/2085 of 19/11/2021 (EU OJ L 427, 30.11.2021, p. 17), the Clean H₂ JU succeeds the FCH2JU as of 30 November 2021.

⁽²⁾ See p. 103 at https://www.clean-hydrogen.europa.eu/about-us/key-documents/strategic-research-and-innovation-agenda_en

⁽³⁾ See p. 163 at https://www.clean-hydrogen.europa.eu/about-us/key-documents/annual-work-programmes_en





⁽⁴⁾ For a list of projects, see online at https://www.clean-hydrogen.europa.eu/projects-repository_en. More comprehensive information is searchable at the Community Research and Development Information Service (CORDIS) under <https://cordis.europa.eu>.

91 Acknowledgements

92 We are grateful to all participants and their respective organisations (see below) for valuable contributions in
 93 developing this report. It includes those who participated in the discussion held at the workshop on 29 September
 94 2023 in Brussels. In addition, we appreciate the opportunity to consult existent testing protocols developed in
 95 the EU funded research projects ELECTROHYPEM⁽⁵⁾, H2FUTURE⁽⁶⁾, HPEM2GAS⁽⁷⁾, NEPTUNE⁽⁸⁾, PRETZEL⁽⁹⁾,
 96 PROMETH2⁽¹⁰⁾, NEWELY⁽¹¹⁾ and ANIONE⁽¹²⁾. We acknowledge the availability and use of electricity grid data
 97 by Elia Transmission Belgium SA under the Creative Commons Public License (CC BY 4.0). We also thank Marc
 98 Steen for reviewing an earlier draft, the Clean H₂ JU for financial support and Nikolaos Lymperopoulos for the
 99 encouragement received.

100 **Authors:** Malkow, T., Pilenga, A.

102 *Note:* Contributors are listed in alphabetical order according to the name of their participating organisation.
 103

	Organisation	Contributor(s)
	accelera by Cummins	Sebastian Herregods
	Commissariat à l'énergie atomique et aux énergies alternatives	Julie Mougin Frédéric Fouda-Onana
	The Chemours Company	Patrick Redon
	Consiglio Nazionale delle Ricerche	Antonino Salvatore Aricò Stefania Siracusano
	Deutsches Zentrum für Luft- und Raumfahrt e. V.	Aldo Saul Gago Rodriguez

⁽⁵⁾ Enhanced performance and cost-effective materials for long-term operation of PEM water electrolyzers coupled to renewable power sources (ELECTROHYPEM) was coordinated by Consiglio Nazionale delle Ricerche (CNR) with JRC, Centre national de la recherche scientifique (CNRS), Solvay Speciality Polymers Italy SpA, ITM Power (Trading) Limited and TRE SpA TOZZI Renewable Energy as partners (CNR, 2012).

⁽⁶⁾ Hydrogen meeting FUTURE needs of low carbon manufacturing value chains (H2FUTURE) was coordinated by VERBUND Energy4Business GmbH with voestalpine Stahl GmbH, K1-MET GmbH, Siemens AG, Austrian Power Grid AG, Stichting Energieonderzoek Centrum Nederland (ECN), Nederlandse Organisatie voor Toegepast Natuurwetenschappelijk Onderzoek (TNO) and Siemens Energy Global GmbH & Co. KG as partners as well as Siemens AG Österreich and Siemens Energy Austria GmbH as associates (VERBUND Energy4Business GmbH, 2017).

⁽⁷⁾ High Performance PEM Electrolyzer for Cost-effective Grid Balancing Applications (HPEM2GAS) was coordinated by CNR with ITM Power (Trading) Limited, Solvay Speciality Polymers Italy SpA, IRD Fuel Cells A/S, Stadtwerke Emden GmbH, Hochschule Emden/Leer and Uniresearch BV as partners (CNR, 2016).

⁽⁸⁾ Next Generation PEM Electrolyser under New Extremes (NEPTUNE) was coordinated by ITM Power (Trading) Limited with Engie, Solvay Speciality Polymers Italy SpA, CNR, IRD Fuel Cells A/S and PRETEXO as partners (ITM Power plc, 2018).

⁽⁹⁾ Novel modular stack design for high pressure PEM water electrolyzer technology with wide operation range and reduced cost (PRETZEL) was coordinated by Deutsches Zentrum für Luft- und Raumfahrt e. V. (DLR) with Westfälische Hochschule, Association pour la Recherche et le Développement des Méthodes et Processus Industriels (ARMINES), Universitatea Politehnica Timișoara, Adamant Aerodiastimikies Efarmoges EIIE, GKN Sinter Metals Filters GmbH, Centre for Research & Technology, Hellas (CERTH), Soluciones Catalíticas IBERCAT S.L. and iGas Energy GmbH as partners as well as École nationale supérieure des mines de Paris (ENSMP) and GKN Powder Metallurgy Engineering GmbH as associates (DLR, 2018).

⁽¹⁰⁾ Cost-effective PROton Exchange MEmbrane WaTer Electrolyser for Efficient and Sustainable Power-to-H₂ Technology (PROMETH2) was coordinated by DLR with CNR, iGas Energy GmbH, Consejo Superior de Investigaciones Científicas (CSIC), ProPuls GmbH, Fundación para el Desarrollo de las Tecnologías del Hidrógeno en Aragón (FHa), AIR LIQUIDE Forschung und Entwicklung GmbH, Chemours Belgium BVBA, Monolithos Catalysts EIIE, Cutting-Edge Nanomaterials UG (haftungsbeschränkt), New nel Hydrogen AS and Forschungszentrum Jülich GmbH (FZJ) as partners (DLR, 2020a).

⁽¹¹⁾ Next Generation Alkaline Membrane Water Electrolyzers with Improved Components and Materials (NEWELY) was coordinated by DLR with Westfälische Hochschule, Commissariat à l'énergie atomique et aux énergies alternatives (CEA), ProPuls GmbH, Air Liquide SA, Fondazione Bruno Kessler (FBK), Cutting-Edge Nanomaterials CenMat UG (haftungsbeschränkt), membrasenz SARRL, Vysoká škola chemicko-technologická v Praze (VSCHT), Ústav makromolekulární chemie AV ČR, v. v. i. and Korea Institute of Science and Technology (KIST) as partners as well as AIR LIQUIDE Forschung und Entwicklung GmbH as associate (DLR, 2020b).

⁽¹²⁾ Anion Exchange Membrane Electrolysis for Renewable Hydrogen Production on a Wide-Scale (ANIONE) was coordinated by CNR with CNRS, HYDROLITE Ltd, TFP Hydrogen Products Ltd, IRD Fuel Cells A/S, Hydrogenics Europe NV and Uniresearch BV as partners as well as Université de Montpellier as associate (CNR, 2020).

	Elogen SAS	Pierre Millet ^(a)
	Forschungszentrum Jülich GmbH	Felix Lohmann-Richters
	Fraunhofer Institut für Chemische Technologie	Felix Dittmar Carsten Cremers Julia Melke
	Fundación para el Desarrollo de las Tecnologías del Hidrógeno en Aragón	Lidia Martínez Izquierdo
	ITM Power plc	Daniel A Greenhalgh
	Johnson Matthey plc	Colleen Jackson Chris Zalis
	ProPuls GmbH	Ulrich Wilhelm Rost
	Schaeffler AG	Peter Bouwman
	Shell Global Solutions International BV	Jeffrey (Jeff) B Martin
	Stiftelsen for industriell og teknisk forskning	Luis Colmenares-Rausseo
	Nederlandse Organisatie voor Toegepast Natuurwetenschappelijk Onderzoek	Johan Buurma Jordi Creus Casanovas Eduardo Da Rosa Silva
	Technische Universiteit Eindhoven	Matheus T (Thijs) de Groot
	Technische Universität Graz	Merit Bodner

104 ^(a) co-affiliated to Université Paris-Saclay

1 Introduction

Water electrolyser (WE) stacks (4.2.78)⁽¹³⁾ used in water electrolyser systems (WE systems) (4.2.79) are at the core of generating clean hydrogen (H₂) in bulk amounts in addition to oxygen (O₂) by the electrolysis (4.2.35) of water (H₂O) using fluctuating electricity particularly from sources of variable renewable energy (VRE). Most industrial WE systems (Figure 1.1) employing commercial WE stacks use low-temperature water electrolysis (LTWEL) technologies, namely alkaline water electrolysis (AEL) (4.2.7) in an alkaline water electrolyser (AWE) (4.2.6) and proton exchange membrane water electrolysis (PEMEL) (4.2.63) in a proton exchange polymer membrane water electrolyser (PEMWE) (4.2.62) (Chatenet *et al.*, 2022, Shih *et al.*, 2022).

Figure 1.1: Schematic of a WE system comprising one or more WE stacks (WE 1 to WE *N*), common balance of plant (BoP) and instrumentation & control devices including safety sensors and software.

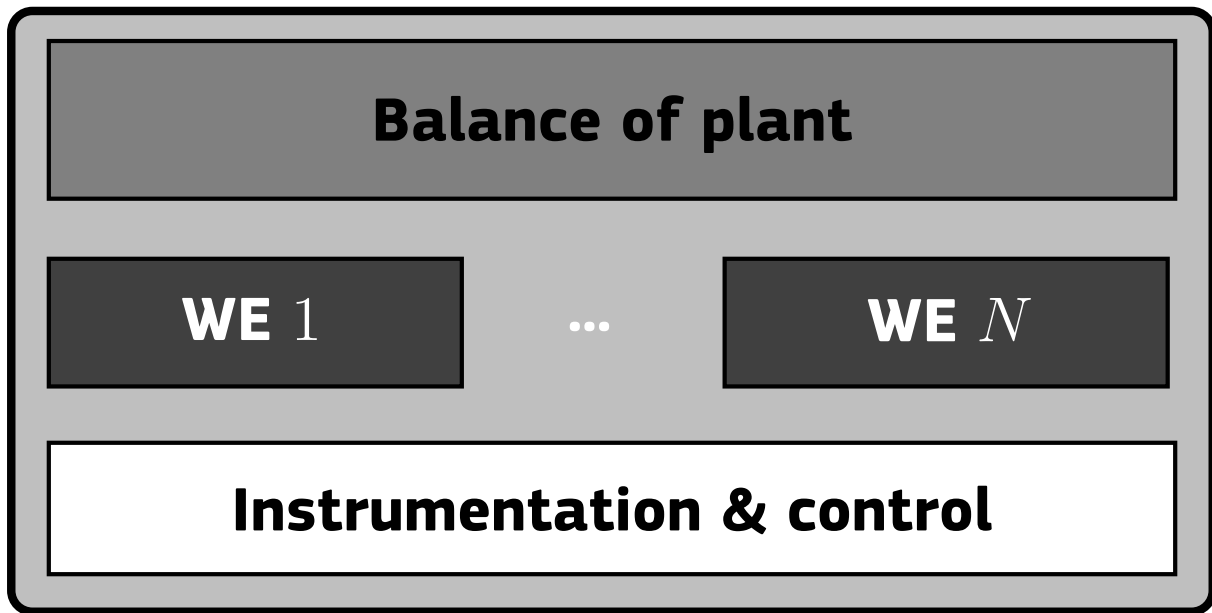

Source: JRC, 2023.

AWE have the advantage of being least reliant on the use of critical raw materials (CRM) (4.2.21). CRM are a serious concern for the European Union (EU) with regard to up-scaling and large-scale deployment of low-temperature water electrolyser (LTWE) technologies (Carrara *et al.*, 2023). PEMWE use CRM in catalysts (4.2.15), namely platinum (Pt) at the cathode (negative electrode) and platinum-group metals (PGM) (4.2.60) oxides such as iridium oxide (IrO_x) or iridium-ruthenium oxide (IrO_x-RuO_y) at the anode (positive electrode) to facilitate the water electrolysis (WEL) reactions in the electrodes of the proton exchange polymer membrane water electrolysis cells (PEMECs), see equation (3.1.4).

PEMWE have the benefits of high hydrogen output pressure and of more flexible operation especially relevant for delivering grid balancing services (Allidières *et al.*, 2019). Note, electricity grids (4.2.29) will exceedingly rely on balancing services in the future compared to the present situation with increasing use of diverse sources of VRE (solar, tidal, wave, wind, etc) in the grid.

Today, WE stacks using anion exchange membrane water electrolysis (AEMEL) (4.2.10) in an anion exchange polymer membrane water electrolyser (AEMWE) (4.2.9) are less common. AEMWE potentially combine the advantages of AEL and PEMEL (see Table 3.1) in a single device (Du *et al.*, 2022, Santoro *et al.*, 2022). In the future, they use de-mineralised liquid water (4.2.24) as in PEMWE while a current variant, namely an alkaline anion exchange polymer membrane water electrolyser (AAEMWE) uses dilute alkaline solution similar to AWE.

Commonly, the manufacturer of the WE system specifies the system boundaries while considering the BoP components (4.2.12) which form part of the system⁽¹⁴⁾. Besides common hardware (piping, valves, actuators, sensors, wiring/cabling, etc), BoP usually consists of

⁽¹³⁾ This number refers to the term defined in section 4.2.

⁽¹⁴⁾ The immediate use of the hydrogen generated may require compression equipment (Sdanghi *et al.*, 2020, Durmuş *et al.*, 2021, Tahan, 2022, Marciuš *et al.*, 2022) as part of the BoP especially in power-to-gas (P-to-G) applications and in industrial processes requiring high pressure hydrogen. In applications of energy storage (ES) (4.2.39) including hydrogen-to-power (H₂-to-P) with hydrogen stored as compressed gaseous hydrogen (CGH₂) (4.2.18) in vessels or large (seasonal) underground storage facilities, compression equipment may be part of the BoP of a particular WE system (Ausfelder *et al.*, 2017). In power-to-mobility (P-to-M) applications with hydrogen stored either as CGH₂ or as liquid hydrogen (LH₂) (4.2.46) in vessels, liquefaction equipment may be part of the BoP of a particular WE system in the latter case.

- 137 • **electric power supply (4.2.30)** such as AC-to-DC (AC/DC) converter when grid-connected, or DC-to-
138 DC (DC/DC) converter when directly coupled (off-grid) to one or another renewable energy source (RES)
139 (**4.2.66**), for example, photovoltaic (PV) array (**4.2.58**) and/or wind turbine (**4.2.81**),
- 140 • **conditioning unit** including pumps, ion exchanger and heat exchanger for feeding de-mineralised water
141 to PEMWE and AEMWE stack(s) and alkaline solution to AWE and AAEMWE stack(s) and
- 142 • **hydrogen purifier (4.2.42)** including liquid/gas separators, cooler(s), dryer(s) and de-oxidiser.

143 Where systems jointly use points of connection (PoCs) for electricity and/or fluid supply and for conveying exiting
144 hydrogen and oxygen as part of a plant, the system boundary as the delineation between system interior and
145 system exterior is to be defined by the manufacturer with the user's agreement.

146 Before their wider deployment in significantly large numbers and at scales ranging from a few hundred
147 megawatts to several tens of gigawatt in capacity for use in ES and industrial applications across the EU and
148 worldwide, stacks used in WE systems have to overcome a number of serious challenges (see section 3.4)
149 by research and development (R&D) efforts and exceedingly, in real-world demonstrations accompanied with
150 capital investment in the said LTWE technologies ⁽¹⁵⁾.

⁽¹⁵⁾ For EU policy measures taken, see, for example, at https://energy.ec.europa.eu/topics/energy-systems-integration/hydrogen_en.

2 Objective and scope of this document

The objective of this document is to propose accelerated stress testing (AST) (4.2.2) protocols (4.2.3) for establishing the performance degradation (4.2.56) of WE stacks used for generating bulk amounts of hydrogen by LTWEL at temperatures usually below 100 °C (373,15 K). Note, seawater electrolysis (Khan *et al.*, 2021), wastewater electrolysis (Cartaxo *et al.*, 2022) and bipolar polymer membrane water electrolysis (BPMEL) (Mayröhöfer *et al.*, 2020) are not considered herein ⁽¹⁶⁾. This also applies to hybrid redox flow batteries (HRFBs) where in addition to their use as ordinary redox flow batteries (RFBs), electrolysis to generate hydrogen is intended (Schmucker *et al.*, 2021).

WE stacks which can be rectangular, square or circular in geometry, use electricity preferably from least dispatchable sources of VRE. A WE stack used in a WE system can be deployed in various applications where hydrogen is used as an energy carrier (4.2.37) (fuel or commodity) among others in ES such as P-to-G, P-to-M (road, rail, maritime) and power-to-X (P-to-X) including power-to-chemical (P-to-C), power-to-liquid (P-to-L) and power-to-fuel (P-to-F), as well as for direct use as feedstock or reducing agent in hydrogen-to-industry (H₂-to-I) processes. By applying the AST protocols (section 6) along with a test plan (4.2.76) to execute a test programme in a test campaign, the performance degradation of WE stacks are established under given test conditions (section 6.3), for example,

- To evaluate R&D progress made,
- To set research and innovation (R&I) priorities for development milestones and technological benchmarks to improve technology and assess impact on cost and
- To make well-informed business decisions regarding the selection of a particular WE stack technology.

The test methods suggested are mainly those contained in standards of the International Organization for Standardization (ISO) and the International Electrotechnical Commission (IEC). Readers are advised to sufficiently familiarise with the referred standards and the test methods described or cited therein ⁽¹⁷⁾.

In addition, we also consider testing procedures previously developed as part of the EU water electrolysis harmonisation activities (Malkow *et al.*, 2018b, Malkow *et al.*, 2018a, Malkow and Pilenga, 2023a). Note, it is not intended to exclude any other suitable testing procedure or test method. The operation profiles (4.2.51) presented (section 6.8.2) serve as examples to establish the durability (4.2.27) of WE stacks by performing accelerated lifetime testing (ALT) (4.2.1) under reference test and operating conditions (section 6.4) as well as AST under stressing operating conditions (4.2.70) (section 6.5). They can be complemented by duty cycles, for example, to reflect realistic RES power generation profiles (section 6.8.2) for on-demand stack operation including the performance of services especially to balance variable loads of renewable energy (4.2.65) on the electricity grid known as balancing services ⁽¹⁸⁾.

The use of RES-derived power profiles for stack testing distinguish these test protocols (4.2.72) from those developed in EU-funded research projects (Enhanced performance and cost-effective materials for long-term operation of PEM water electrolyzers coupled to renewable power sources (ELECTROHYPEM), Hydrogen meeting FUTURE needs of low carbon manufacturing value chains (H2FUTURE), High Performance PEM Electrolyzer for Cost-effective Grid Balancing Applications (HPeM2GAS), Next Generation PEM Electrolyzer under New Extremes (NEPTUNE), Novel modular stack design for high pressure PEM water electrolyzer technology with wide operation range and reduced cost (PRETZEL), Cost-effective PROton Exchange MEmbrane WaTer Electrolyser for Efficient and Sustainable Power-to-H₂ Technology (PROMETH2), Next Generation Alkaline Membrane Water Electrolyzers with Improved Components and Materials (NEWELY) and Anion Exchange Membrane Electrolysis for Renewable Hydrogen Production on a Wide-Scale (ANIONE)) (Aricò *et al.*, 2013, Aricò *et al.*, 2016, Aricò *et al.*, 2018, Strataki, 2018, Stiber *et al.*, 2020, Fouda-Onana, 2020, Aricò *et al.*, 2020).

These protocols constitute testing guidance including mandatory requirements and agreed reference operating conditions for WE stacks to establish their performance degradation in a given power-to-hydrogen (P-to-H₂) application. They allow for sufficient flexibility when the test plan (section 6.6) of a scheduled test campaign is drawn up for a specific test programme addressing the use of the test item (4.2.74) in the target application. Thus, the test plan is to provide further details on

- test execution including
 - setting of test input parameters (TIPs) (4.2.73) with permissible variations,

⁽¹⁶⁾ Bipolar polymer membrane water electrolyser (BPMWE) composed of bipolar polymer membrane water electrolysis cells (BPMWECs) perform BPMEL without gas evolution at the AEM-PEM bipolar junction.

⁽¹⁷⁾ Standards, Technical Specification (TS) and Technical Reports (TRs) are not open access but they can be purchased from ISO and IEC directly or their constituting national committees (NCs).

⁽¹⁸⁾ Currently, working group (WG) 32 of ISO Technical Committee (TC) 197 prepares the approved working item (AWI) entitled "ISO 22734-2 Hydrogen generators using water electrolysis - Industrial, commercial, and residential applications - Part 2: Testing guidance for performing electricity grid service".

- 201 - test criteria for acceptance, failure and emergency stop, and
202 - operation profiles (section 6.8)
- 203 based on the stated purpose(s) and objective(s) of the tests and
- 204 ● where necessary, provide more specific details on
- 205 - test set-up (*e.g.* sensor positions, stack compression, etc) including specification and requirements
206 of test equipments,
 - 207 - testing procedures including start-up and shut-down including emergency stop,
 - 208 - instrumentation, test and measurement methods (section 6.2),
 - 209 - data acquisition (DAQ) (**4.2.23**) and post-processing of test results including an agreed set of test
210 output parameters (TOPs) (**4.2.75**).
- 211 Importantly, the application of these AST protocols to WE stacks does not require the specification of the type and
212 characteristics of the tested stack. Also users may selectively execute tests that are suitable for the objective(s)
213 and purpose(s) of their test campaign from among those described herein.

3 Overview of low-temperature water electrolysis technologies

3.1 WEL electrode reactions

The generation of one mole of gaseous hydrogen, $\text{H}_2(\text{g})$ (subscript (g) denotes gaseous phase), along with half a mole of gaseous oxygen, $\text{O}_2(\text{g})$, by the electrolysis of one mole of liquid water, $\text{H}_2\text{O}(\text{l})$ (subscript (l) denotes liquid phase), as shown in the overall reaction



is performed in a water electrolyser. The three LTWEL technologies considered are

• **Alkaline water electrolysis:** Gaseous oxygen is formed by oxidising hydroxide ions (OH^-) in the aqueous phase (denoted by subscript (aq)) of the alkaline solution, typically 20-40 wt-% KOH (potassium hydroxide or lye), as electrolyte (**4.2.36**) at the anode or oxygen electrode in the oxygen evolution reaction (OER):

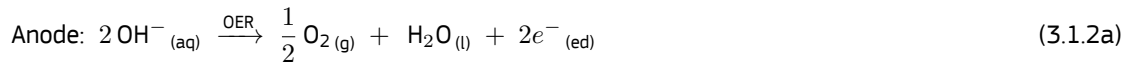

under an applied positive difference in potential (voltage) in excess of the open circuit potential (OCP) (U_{OCP}) sometimes called open circuit voltage (OCV) (U_{OCV}) resulting from the supplied direct current (DC) (I_{dc}). Simultaneously, at the cathode or hydrogen electrode, gaseous hydrogen is formed by reducing liquid water in the hydrogen evolution reaction (HER):

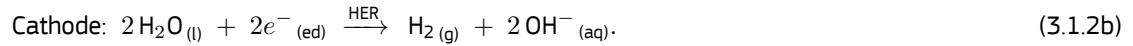

The electrons (e^-) are conducted via the electrodes (subscript (ed) denotes electrode) connected to an external circuit (DC power supply) entailing an ohmic resistance. The hydroxide ions diffuse along the potential-induced concentration gradient within the electrolyte of the alkaline water electrolysis cell (AEC) in the AWE stack from cathode to anode via a diaphragm.

• **Anion exchange membrane water electrolysis:** Gaseous oxygen is formed by oxidising hydroxide ions at the anode in the OER:

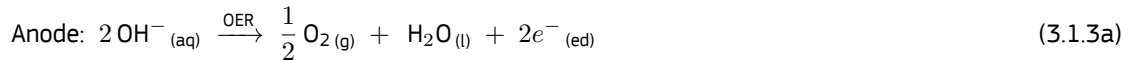

under an applied potential in excess of OCV. Gaseous hydrogen is formed simultaneously by reducing liquid water at the cathode in the HER:

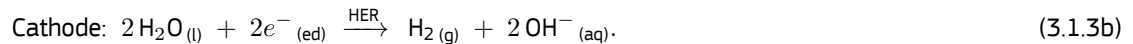

Whereas electrons are conducted via the electrodes connected to an external circuit, hydrated hydroxide ions are conducted by the vehicular mechanism (standard diffusion) and the Grotthuss (proton hopping) mechanism (Dong *et al.*, 2018, Chen *et al.*, 2016) through the anion exchange polymer membrane (AEM) electrolyte of the anion exchange polymer membrane water electrolysis cell (AEMEC) in the AEMWE stack. In the case of an alkaline anion exchange polymer membrane electrolysis cell (AAEMEC), water is substituted by a dilute lye solution. Note, the identical electrode reactions (3.1.2) and (3.1.3) proceed in different media, namely alkaline solution in AWE according to reactions (3.1.2) and liquid water in AEMWE according to reactions (3.1.3).

• **Proton exchange membrane water electrolysis:** Gaseous oxygen is formed by oxidising water at the anode in the OER:

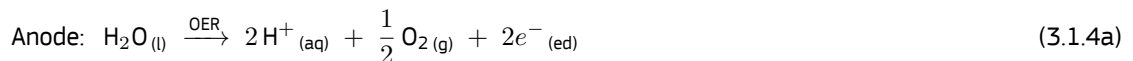

under an applied potential in excess of OCV. Gaseous hydrogen is formed simultaneously by reducing protons (H^+) at the cathode in the HER:



Whereas electrons are conducted via the electrodes connected to an external circuit, hydrated protons (H_3O^+) are conducted by the vehicular and Grotthuss mechanisms through the proton exchange polymer membrane (PEM) electrolyte of the PEMEC in the PEMWE stack. That is, water is also yielded on the cathode due to electro-osmosis (**4.2.31**).

3.2 Materials, operating conditions and technology readiness levels

Whereas AWEs with technology readiness level (TRL) 9 at the MW scale are mature as they benefit from many decades of operational experience in the chlor-alkali electrolysis process, PEMWEs with PEMECs as constituting units having TRL 8 to 9 at the kW to MW scale are most mature among the polymer membrane based WEs. The least mature with TRL 6 at the kW scale are AEMWEs using AEMECs as constituting units employing dilute alkaline solution. In the future, AEMWEs may be fed by pure water.

Most common in AWEs are Zirfon[®], a porous composite made of zirconia-polysulfone coated open mesh polyphenylene sulfide (PPS) polymer fabric, as porous separator membrane, nickel (Ni) or Ni/NiFe alloys (on steel core) as anode and nickel or Ni alloy coated stainless steel as cathode. Current collectors (4.2.22) are made of nickel plates or Ni-coated steel. Typically, AWEs operate at temperatures between 60 to 90 °C (333,15 K to 363,15 K), current densities of between 0,2 A/cm² and 0,9 A/cm² and atmospheric pressure or pressures up to 30 bar (3 MPa) (Ehlers *et al.*, 2023, Brauns and Turek, 2020).

AEMWEs often use permeable fluorine-free hydrocarbon polymers as electrolyte membranes, non-PGM especially Co, Ni or Fe, their alloys and (mixed) oxides as anodes and Ni and its alloys as cathodes besides Pt. Typically, AEMWEs operate at temperatures between 40 to 80 °C (313,15 K to 353,15 K), current densities of between 0,5 A/cm² and 2 A/cm² and atmospheric pressure or at pressure from 8 to 35 bar (800 kPa to 3,5 MPa). The gas diffusion layer (GDL) (4.2.40) are made of carbon paper or cloth, titanium sheets, stainless steel felts or Ni foam (Miller *et al.*, 2020, Du *et al.*, 2022). They provide for electronic conductivity between the catalyst layer (CL) (4.2.16) and the bipolar plates (biPs) (4.2.13) and remove gaseous products (hydrogen and oxygen).

Most often, PEMWEs use perfluoro sulfonic acid (PFSA) (4.2.54) as electrolyte membrane, PGM oxides such as IrO_x and IrO_x-RuO_y as anode catalysts and PGM such as Pt as cathode catalyst. Typically, PEMWEs operate at temperatures between 50 to 90 °C (323,15 K to 363,15 K), current densities of 1 A/cm² to 4 A/cm² and atmospheric pressure or at differential pressures of up to 50 bar (5 MPa). Their biPs are made of titanium (Ti) or graphite (Kumar and Lim, 2023, Carmo *et al.*, 2013).

3.3 Stack operation modes

Under galvanostatic conditions, direct current provided to a WE stack results in a DC voltage (U_{dc}) across each cell. Adding the voltage of all series-connected water electrolysis cells (WECs) results in the stack voltage. Under potentiostatic conditions, a DC voltage applied to a WE stack results in a current flowing through the stack perpendicular to the active electrode area (A_{act}) (4.2.5) of all in-series WECs of the stack. DC electricity is in the form of electric energy (E_{el}):

$$E_{el} \text{ (kWh)} = P_{el} \text{ (kW)} \cdot t \text{ (h)} \text{ where} \quad (3.3.1a)$$

P_{el} is electric power and t is the duration of applied electric power. Specifically, the electric power of a stack is DC power:

$$P_{el,dc} \text{ (kW)} = U_{dc} \text{ (kV)} \cdot I_{dc} \text{ (A)}. \quad (3.3.1b)$$

The electric power density of a stack ($P_{el,d,stack}$) is calculated as

$$P_{el,d,stack} \text{ (kW/cm}^2\text{)} = U_{dc} \text{ (kV)} \cdot J_{stack} \text{ (A/cm}^2\text{)} \text{ where} \quad (3.3.1c)$$

$$J_{stack} \text{ (A/cm}^2\text{)} = \frac{I_{dc} \text{ (A)}}{A_{act} \text{ (cm}^2\text{)}} \quad (3.3.1d)$$

is the stack current density. Depending on temperature (T), the three operation modes of a WE stack are

- **Endothermic operation:** The water temperature decreases from input to output of the stack with its voltage below the thermal-neutral voltage⁽¹⁹⁾ but above the reversible potential⁽²⁰⁾. Among the three modes of stack operation, this mode corresponds to the highest energy efficiency (η_e) (4.2.38) of the stack (section 6.7.13). But, it comes at the expense of a low hydrogen output rate (section 6.7.8). The heat required for the WEL reactions (3.1.2), (3.1.3) and (3.1.4) to proceed as desired stems under presumed adiabatic conditions from the supplied water rather than from Joule (ohmic) heating (4.2.44) due to an insufficient supply of electricity.

⁽¹⁹⁾ At standard ambient pressure and standard ambient temperature (4.2.69) of liquid water (pH = 0), the thermal-neutral voltage (U_{tn}) is 1,481 V while this voltage is 1,473 V at 80 °C (353,15 K). However, the thermal-neutral voltage decreases with increasing temperature and higher pH value.

⁽²⁰⁾ At standard ambient pressure and standard ambient temperature of liquid water (pH = 0), the reversible potential (U_{rev}) is 1,229 V vs SHE while this potential is 1,184 V vs SHE at 80 °C (353,15 K). However, the reversible potential decreases with increasing temperature and higher pH value while it slightly increases with increasing pressure.

- 301 • *Isothermal (thermal-neutral) operation:* The water temperature is virtually the same at both input and output
 302 of the WE stack. The stack voltage is basically the thermal-neutral voltage. The additional heat required to
 303 sustain the equilibrium of the WEL reactions (3.1.2), (3.1.3) and (3.1.4) usually stems from Joule heating due
 304 to the externally supplied electricity required to establish the reversible potential.
- 305 • *Exothermic operation:* The water temperature increases from input to output of the WE stack with its voltage
 306 above the thermal-neutral voltage. As a result, heat is formed by Joule heating due to the supplied excess
 307 electricity. In this mode, the heat generated is more than that required to sustain the WEL reactions (3.1.2),
 308 (3.1.3) and (3.1.4). An advantage of this mode is that more supplied electricity means a higher hydrogen
 309 output. It comes at the expense of high overvoltages (overpotentials) (4.2.52) or voltage gains and an
 310 increase in performance degradation upon prolonged operation at high current densities ($> 1 \text{ A/cm}^2$). Hence,
 311 voltage limits not exceeding 3,0 V for AEC, 2,0 V for AEMEC and 2,5 V for PEMEC are common (Kumar and
 312 Lim, 2022) to prevent excessive stack degradation. At WE system level, any recovered heat boosts the overall
 313 energy efficiency of the system.

314 3.4 Advantages, disadvantages and challenges

315 Table 3.1 lists common advantages, disadvantages and main challenges of the three LTWE technologies.

Table 3.1: Common advantages, disadvantages and main challenges of three major LTWEL technologies (AWE, AEMWE and PEMWE)

	AWE	AEMWE	PEMWE
Advantages	relatively high energy efficiency ^(a)	use of less expensive non-PGM catalyst ^(b)	high energy efficiency ^(c)
	use of less expensive non-PGM catalysts materials ^(d) relatively low capital expenditure (CAPEX)	low water impurity sensitivity	fast response time including rapid start-up and shut-down ^(e) small footprint, compact, light-weight and simpler BoP
Disadvantages	use of corrosive alkaline electrolyte limited tolerance to lye impurities ^(f) low current density, pressure and gas purity and limited operational flexibility	limited response time low ionic conductivity	use of expensive cell materials ^(g) limited tolerance to impurities ^(f) sensitive to feed water quality
		safety risk due to species (hydrogen and/or oxygen) crossover ^(h)	
Challenges	PTLs free of PGM coatings with integrated MPLs and catalysts operating at higher temperatures (enabling higher efficiencies)	AEM improvement in chemical and thermo-mechanical stability	reduction and eventual replacement of PGM oxide as catalysts ⁽ⁱ⁾ counteracting corrosion and low conductivity in passive layers on current collectors
	improvement of (micro-porous) membranes to reach higher ionic conductivities (enabling higher current densities) with better mechanical properties (enabling thinner membranes) and reduced gas crossover (enabling lower power operation without compromising safety)		substitution of fluoropolymers especially perfluoroalkyl and polyfluoroalkyl substances (PFAS) (4.2.53) by PEM with lower gas diffusivity ^(j)

316 *Note:* This table does not claim to present an exhaustive list of advantages and disadvantages.

317 ^(a) Typically, the energy efficiency of AWE stacks is 70-80 % (higher heating value (HHV)).

318 ^(b) for example, nickel or cobalt

319 ^(c) Typically, the energy efficiency of PEMWE stacks is above 70 % (HHV).

320 ^(d) Often, Ni and Ni alloys are used.

321 ^(e) Relevant to ensure rapid responses to fluctuating power from variable RES.

322 ^(f) Typically, these impurities are dissolved minerals and other contaminants.

323 ^(g) These include ion exchange membranes (IEMs) (4.2.43) as electrolyte, Pt-based catalysts at the cathode and iridium oxides based catalysts at the anode with high CAPEX.

324 ^(h) Crossover of hydrogen to the oxygen electrode and oxygen to the hydrogen electrode can lead to the formation of explosive atmospheres.

325 ⁽ⁱ⁾ Especially, IrO_x and IrO_x-RuO_y as OER catalysts in the anode and Pt as HER catalyst in the cathode.

326 ^(j) In PEMECs, the PEM electrolyte, ionomer, gaskets and sealants frequently use fluoropolymers.

327 *Source:* Joint Research Centre (JRC), 2023

328

329 The most mature among these three technologies is the AWE technology. AWEs are initially prime candidates
330 for reliable hydrogen generation in bulk amounts. In the midterm, they will likely be increasingly replaced or
331 complemented by more versatile PEMWEs. In the more distant future, less mature AEMWE technology could
332 become the dominant LTWE technology. Often, AEMWEs are portrayed as beneficially uniting the advantages of
333 AWEs and PEMWEs without necessarily sharing their drawbacks.

334 However, the two most demanding challenges encountered today by the three LTWE technologies are:

- 335 ● Upon completion of the ongoing REACH restriction process ⁽²¹⁾, the possibility of a future ban by the EU
336 on the use of PFAS-containing materials (EC, 2020b) in products placed on the single market ⁽²²⁾ and
- 337 ● Without realising high iridium (Ir) recycling rates, the scarcity of iridium on earth threatening the scale-up
338 of PEMEL technology to the terrawatt-scale globally (Clapp *et al.*, 2023, Kibsgaard and Chorkendorff,
339 2019, Kiemel *et al.*, 2021).

340 As a result, some WEC materials used in stacks will inevitably be different to those used presently once these
341 challenges are met progressively in the future ⁽²³⁾. Ideally, this happens without changing too many key
342 performance indicator (KPI) **(4.2.45)** targets. Also, the operating conditions of WE stacks and their mode(s) of
343 operation may require adaptation since new WEC materials may have different properties and stack design could
344 change. In addition, WEC materials and their morphologies integrated into WE stacks and interfaces within WE
345 stacks may undergo iterative optimisation, including possible modifications in configuration and design suitable
346 for high-throughput processing and mass manufacture of WE stacks.

347 Also, the generation and consumption patterns of electricity will change. Future electricity supply will be
348 more variable as more and more RES installations of increasingly larger size are connected and their type
349 and scale variety increases. Most probable, future smart grids **(4.2.68)** will exceedingly rely on autonomous
350 distributed energy resources (DER) **(4.2.26)** managed by continuously improving artificial intelligence (AI)-based
351 software. It includes automated on-demand deployment and disengaging of one or another WE system as part
352 of a grid with fluctuating electricity.

353 Further, a WE system directly coupled to a large-scale RES installation as part of solar or wind energy farm
354 will increasingly use AI-based supervisory control and data acquisition (SCADA) **(4.2.71)** software with predictive
355 energy and weather forecasting and monitoring so that the supply of electricity to such a system or WE plant
356 will not only be dependent on weather conditions and actual energy demand but also revenue considerations as
357 regards the sale of renewable electricity versus clean hydrogen.

358 As a result, the mechanisms of material degradation in individual WECs (*e.g.* iridium dissolution and re-
359 deposition, carbon catalyst support corrosion with agglomeration of platinum nano-particles, membrane thinning
360 with fluoride release, and blocking of ion exchange sites by foreign cations in lye/liquid water feed) and thus of
361 the performance degradation of WE stacks (*e.g.* passivation by titanium oxide formation on Ti-based PTL and
362 biP) as currently known are likely to differ in their significance and extent. New degradation phenomena could
363 emerge while degradation phenomena of little relevance today, could become more dominant.

364 Along with future material developments and stack optimisation, ongoing research into degradation phe-
365 nomena of WEC materials and stack components and the mechanisms for their explanation will need to address
366 the set-up of AST protocols for assessing the performance degradation of WE stacks in real-world applica-
367 tions dominated by fluctuating RES-derived electricity for the production of hydrogen. Developed AST protocols
368 therefore need to consider the mentioned challenges and must provide for the necessary user flexibility.

⁽²¹⁾ See at <https://echa.europa.eu/regulations/reach/restrictions/restriction-procedure>

⁽²²⁾ Due to risks (toxic and bio-accumulative effects) for human health, animals and the environment owing primarily to the strength of the carbon-fluorine (C-F) covalent bond in fluoropolymers, which makes them water-, oil- and grease-repellent and highly resistant to chemical and thermo-mechanical attacks, actions proposed by the European Commission (EC) aim at phasing out PFAS use in the EU unless proven essential for society (EC, 2020a); see also <https://www.eea.europa.eu/publications/emerging-chemical-risks-in-europe> and <https://echa.europa.eu/hot-topics/perfluoroalkyl-chemicals-pfas>. PFAS containing materials are also used in several BoPs components of WE systems, for example, in pumps, valves, cables, and electronics. In addition, fluoropolymers (PFAS membranes) are used in the electrolysis of potassium chloride (KCl) to create KOH, to be used in AEL technologies.

⁽²³⁾ The manufacture and use of PFAS substitute materials in stacks may pose other challenges and could have risks to human health and the environment, too.

369 4 Terminology

370 4.1 General

371 Terms and definitions used in this document are given below and in two JRC EUR reports (Tsotridis and Pilenga,
372 2018, Malkow *et al.*, 2021). In addition, ISO and IEC maintain terminological databases at the following websites:

373 - ISO Online browsing platform available at <https://www.iso.org/obp>.

374 - IEC Electropedia available at <http://www.electropedia.org>.

375 The verbal forms used have the following meaning:

- 376 • “shall” indicates a requirement,
- 377 • “should” indicates a recommendation,
- 378 • “may” indicates a permission and
- 379 • “can” indicates a possibility or a capability.

380 Reference to Système International d’Unités (SI) coherent (derived) units includes, as appropriate, metric
381 prefixes. Following clause 9.1 of ISO/IEC Directives, Part 2 (ISO and IEC, 2021), decimal fractions are denoted
382 by comma. Alongside SI units, non-SI units may be used as customary. For example, we use degree Celsius (°C)
383 as unit of temperature (T) alongside Kelvin (K) and kilo Watt hours (kWh) as unit of energy (E) instead of kilo
384 Joule (kJ).

385 4.2 Terms and definitions

386 4.2.1 accelerated lifetime testing (ALT)

387 destructive testing of a test item (**4.2.74**) by subjecting it to aggravated conditions (*e.g.* current, pres-
388 sure, temperature, voltage, etc) in excess of nominal conditions of real-life use, in an attempt to reveal
389 likely faults and modes of failure in a short amount of time by increasing their frequency of occurrence,
390 magnitude, duration, or any combination thereof and thereby, to assess the reliability of the item mainly
391 for commercial purposes

392
393 Note 1 to entry: ALT may help to predict the remaining useful life and required maintenance intervals of
394 the test item. It shall not alter the basic failure modes and mechanisms, or their relative prevalence.

395 4.2.2 accelerated stress testing (AST)

396 testing of a test item (**4.2.74**) by applying high levels of stress (*e.g.* current, pressure, temperat-
397 ure, voltage, etc) in excess of those under normal conditions of use to shorten the test duration in
398 an attempt to trigger the same performance degradation mechanism(s) as would presumably occur for
399 a longer exposure of the test item when tested under normal conditions of use mainly to advance the
400 maturity of the test item

401
402 Note 1 to entry: AST is intentionally non-destructive and mainly for identifying potentially detrimental
403 operating conditions and modes of operation as well as unsuitable designs and ineffective materials and
404 components. It may also be performed to identify and to characterise performance degradation (**4.2.56**)
405 and their mechanisms(s) occurring in the test item. Design of experiment (DoE) (**4.2.25**) along with
406 physics-based modelling and post-mortem characterisation of the test item may help to gain insight into
407 and to understand the relationship between the applied stress and performance degradation and their
408 mechanism(s).

409 4.2.3 AST protocol

410 test protocol (**4.2.72**) specific for accelerated stress testing (**4.2.2**)

411 4.2.4 activation polarisation

412 part of the electrode polarisation (**4.2.33**) arising from a charge-transfer step of the electrode reaction

413 [Source: IEV 482-03-05]

415 4.2.5 active electrode area (A_{act})

416 geometric area of the electrode perpendicular to the direction of the current flow

417
418 [Source: IEV 485-02-08]

419

420 Note 1 to entry: Active electrode area is expressed in cm².

421 **4.2.6 alkaline water electrolyser (AWE)**

422 water electrolyser using alkaline solution as electrolyte (**4.2.36**)

423

424 [Source: JRC EUR 30324 EN report, term 680 (Malkow *et al.*, 2021)]

425 **4.2.7 alkaline water electrolysis (AEL)**

426 electrolysis (**4.2.35**) that employs an alkaline solution as electrolyte (**4.2.36**)

427

428 [Source: JRC EUR 30324 EN report, term 678 (Malkow *et al.*, 2021)]

429 **4.2.8 anion exchange polymer membrane (AEM)**

430 polymer based membrane with an anion conductivity, which acts as an electrolyte (**4.2.36**) and a separator
431 between anode and cathode

432

433 [Source: JRC EUR 30324 EN report, term 681 (Malkow *et al.*, 2021)]

434 **4.2.9 anion exchange polymer membrane water electrolyser (AEMWE)**

435 electrolyser (**4.2.34**) that employs a polymer with (hydroxide) ion exchange capability as the electrolyte
436 (**4.2.36**)

437

438 [Source: JRC EUR 30324 EN report, term 684 (Malkow *et al.*, 2021)]

439 **4.2.10 anion exchange membrane water electrolysis (AEMEL)**

440 electrolysis (**4.2.35**) that employs an anion exchange polymer membrane (**4.2.8**) as electrolyte (**4.2.36**)

441

442 [Source: JRC EUR 30324 EN report, term 682 (Malkow *et al.*, 2021)]

443 **4.2.11 artificial intelligence (AI)**

444 set of methods or automated entities that together build, optimize and apply a model so that the system
445 can, for a given set of predefined tasks, compute predictions, recommendations, or decisions

446

447 [Source: ISO/TR 6026:2022, 3.3 (ISO, 2022b)]

448 **4.2.12 balance of plant (BoP)**

449 supporting and auxiliary components, associated subsystems and structures based on the source of
450 electricity and site-specific requirements and integrated into a comprehensive water electrolyser system
451 (**4.2.79**) necessary to generate hydrogen

452 **4.2.13 bipolar plate (biP)**

453 conductive plate separating individual cells in a water electrolyser stack (**4.2.78**), acting as current collector
454 (**4.2.22**) and providing mechanical support for the electrodes

455 **4.2.14 Bode plot**

456 combined graphical representation of impedance modulus (absolute value) and phase angle (argument)
457 as functions of frequency on a logarithmic scale

458

459 Note 1 to entry: This plot is named after Hendrik Wade Bode (1905-1982).

460 **4.2.15 catalyst**

461 substance that accelerates an electrochemical reaction without being consumed itself

462

463 Note 1 to entry: The catalyst lowers the activation energy of the reaction, allowing for an increase
464 in the reaction rate.

465

466 [Source: IEV 485-01-01]

467 **4.2.16 catalyst layer (CL)**

468 porous region adjacent to either side of the electrolyte (**4.2.36**), containing the electro-catalyst, typically
469 with ionic and electronic conductivity

470

471 Note 1 to entry: The catalyst layer comprises the spatial region where the electrochemical reactions
472 take place.

473
474

[Source: IEV 485-02-06]

475 **4.2.17 cold start**

476 start-up when the test item (**4.2.74**) is at ambient temperature

477 **4.2.18 compressed gaseous hydrogen (CGH₂)**

478 gaseous hydrogen which has been compressed and stored for later use

479 **4.2.19 compression factor** (f_{compr})

480 positive multiplier of less than unity used to shorten the original duration of an operation profile (**4.2.51**)

481 **4.2.20 concentration polarisation**

482 part of the electrode polarisation (**4.2.33**) arising from concentration gradients of electrode reactants and
483 products

484
485 [Source: IEV 482-03-08]

486
487 Note 1 to entry: Concentration polarisation is most relevant at high current densities. In water elec-
488 trolysis cells, concentration polarisation can result in a non-proportional increase in voltage.

489 **4.2.21 critical raw materials (CRM)**

490 materials that, according to a defined classification methodology, are economically important and have a
491 high-risk associated with their supply

492
493 [Source: ISO 14009:2020, 3.2.14 (ISO, 2020c)]

494 **4.2.22 current collector**

495 conductive material in a water electrolyser stack (**4.2.78**) that collects electrons from the anode side or
496 conducts electrons to the cathode side

497 **4.2.23 data acquisition (DAQ)**

498 process of collecting and entering data

499
500 [Source: ISO 15143-1:2010, 3.1.4 (ISO, 2010a)]

501 **4.2.24 de-mineralised water**

502 water of which the mineral matter or salts have been removed by de-ionisation

503
504 [Source: ISO 23321:2019, 3.1 (ISO, 2019b)]

505 **4.2.25 design of experiment (DoE)**

506 systematic methodology for collecting information to guide improvement of any process

507
508 Note 1 to entry: Statistical models are developed to represent the process under analysis.
509 Note 2 to entry: Simulation tools and optimisation can be applied to test and confirm specific improvements.

510
511 [Source: ISO 13053-2:2011, 2.12 (ISO, 2011a)]

512 **4.2.26 distributed energy resources (DER)**

513 generators (with their auxiliaries, protection and connection equipment), including loads having a gener-
514 ating mode (such as electrical energy storage systems), connected to a low-voltage or a medium-voltage
515 network

516
517 [Source: IEV 617-04-20]

518 **4.2.27 durability**

519 ability of a test item (**4.2.74**) to maintain its performance characteristics (**4.2.55**) as required, under given
520 conditions of use and maintenance

521 **4.2.28 durability test**

522 test intended to verify whether or to evaluate to which degree a test item (**4.2.74**) is able to maintain its
523 performance characteristics (**4.2.55**) over a period of use

- 524 **4.2.29 electricity grid**
525 public electricity network
526
527 [Source: ISO 52000-1:2017, 3.4.8 (ISO, 2017a)]
- 528 **4.2.30 electric power supply**
529 provision of electric energy from a source
530
531 [Source: IEV 151-13-75]
- 532 **4.2.31 electro-osmosis**
533 flow of water induced by a direct electric current applied across a membrane separating two electrolytes
534
535 [Source: IEV 891-02-84]
536
537 Note 1 to entry: The membrane can also be a diaphragm.
- 538 **4.2.32 electrochemical cell**
539 composite system in which the supplied electric energy mainly produces chemical reactions or, conversely,
540 in which the energy released by chemical reactions is mainly delivered by the system as electric energy
541
542 [Source: IEV 114-03-01]
543
544 Note 1 to entry: In the first case, an electrochemical cell is also known as an electrolytic cell.
- 545 **4.2.33 electrode polarisation**
546 accumulation or depletion of electric charges at an electrode, resulting in a difference between the elec-
547 trode potential with current flow, and the potential without current flow or equilibrium electrode potential
548
549 [Source: IEV 114-02-15]
- 550 **4.2.34 electrolyser**
551 device that performs electrolysis (**4.2.35**)
552
553 [Source: ISO/TR 15916:2015, 3.33 (ISO, 2015)]
- 554 **4.2.35 electrolysis**
555 method of separating and neutralising ions by an electric current in an electrolytic cell
556
557 [Source: IEV 114-04-09]
- 558 **4.2.36 electrolyte**
559 liquid or solid substance containing mobile ions that render it ionically conductive
560
561 [Source: IEV 485-03-01]
562
563 Note 1 to entry: The electrolyte is the main distinctive feature of the different LTWEL technologies.
- 564 **4.2.37 energy carrier**
565 substance or phenomenon that can be used to produce mechanical work or heat or to operate chemical
566 or physical processes
567
568 [Source: ISO 52000-1:2017, 3.4.9 (ISO, 2017a)]
- 569 **4.2.38 energy efficiency (η_e)**
570 ratio of useful energy output to the total energy input including all parasitic and auxiliary energy needed
571 to operate the system
572
573 Note 1 to entry: Energy efficiency is expressed in % on the basis either of lower heating value (LHV)
574 or higher heating value (HHV) which should be stated.
- 575 **4.2.39 energy storage (ES)**
576 action or method used to accumulate, retain and release energy for later use in an energy using system
577
578 [Source: ISO/IEC 13273-1:2015, 3.1.5 (ISO and IEC, 2015a)]

579 **4.2.40 gas diffusion layer (GDL)**

580 porous substrate placed between the catalyst layer (**4.2.16**) and the bipolar plate (**4.2.13**) to serve as an
581 electric contact and allow the access of reactants to the catalyst layer and the removal of reaction products

582
583 [Source: IEV 485-04-05]

584 **4.2.41 hot start**

585 start-up when the item test (**4.2.74**) is within its normal operating temperature range

586 **4.2.42 hydrogen purifier**

587 equipment to remove undesired constituents from the hydrogen

588
589 Note 1 to entry: Hydrogen purifiers can comprise purification vessels, dryers, filters and separators.

590
591 [Source: ISO 19880-1:2020, 3.41 (ISO, 2020d)]

592 **4.2.43 ion exchange membrane (IEM)**

593 polymer sheet that contain negatively or positively charged functional groups in its polymer matrix de-
594 signed to conduct cations or anions while blocking opposite charged ions

595
596 [Source: ISO 20468-6:2021, 3.1.18 (ISO, 2021a)]

597 **4.2.44 Joule heating (ohmic heating)**

598 heating caused by an electric current through a resistive material

599
600 [Source: IEV 815-15-41]

601
602 Note 1 to entry: It is named after James Prescott Joule (1818-1889).

603 **4.2.45 key performance indicator (KPI)**

604 quantifiable level of achieving a critical objective

605
606 Note 1 to entry: The KPIs are derived directly from, or through an aggregation function of, physical
607 measurements, data and/or other KPIs.

608
609 [Source: ISO 22400-1:2014, 2.1.5 (ISO, 2014)]

610 **4.2.46 liquid hydrogen (LH₂)**

611 hydrogen that has been liquefied, i.e. brought to a liquid state

612
613 [Source: ISO 13984:1999, 3.4 (ISO, 1999)]

614 **4.2.47 machine learning (ML)**

615 process using algorithms rather than procedural coding that enables learning from existing data in order
616 to predict future outcomes

617
618 [Source: ISO/TR 22100-5:2021, 3.2 (ISO, 2021b)]

619 **4.2.48 Nyquist plot**

620 graphical representation of the real component of impedance versus the negative of the imaginary com-
621 ponent of impedance in rectangular coordinates

622
623 Note 1 to entry: This plot is named after Harry Nyquist (1889-1976).

624 **4.2.49 ohmic polarisation**

625 polarisation caused by the resistance to the flow of ions in the electrolyte (**4.2.36**) and of electrons in the
626 electrodes, bipolar plates (**4.2.13**), and current collectors (**4.2.22**)

627
628 Note 1 to entry: The term "ohmic" refers to the fact that the voltage drop follows Ohm's law proportional to
629 the current with an ohmic resistance (called "internal resistance" of the cell) as the proportionality constant.

630
631 [Source: IEV 485-15-03]

632 **4.2.50 operating (working) point**

633 point on a characteristic performance curve representing the values of variable quantities at which usual
634 operation is expected and optimum efficiency is desired

635

636 Note 1 to entry: Characteristic performance curves of a water electrolyser stack (**4.2.78**) are direct
637 current-DC voltage curves and energy efficiency(electrical efficiency)-electric power curves.

638 **4.2.51 operation profile**

639 curve representing electric power, current or voltage against time used to illustrate the variance in electric
640 power, current or voltage during a given time interval

641 **4.2.52 overvoltage (overpotential)**

642 voltage difference between the measured electrode potential and the equilibrium potential

643

644 [Source: ISO 8044:2020, 7.1.30 (ISO, 2020a)]

645

646 Note 1 to entry: In WE stacks, overvoltage relates to a given current density under specified conditions.

647 **4.2.53 perfluoroalkyl and polyfluoroalkyl substances (PFAS)**

648 commonly used international abbreviation for organic compounds with replacement of most or all hydro-
649 gen atoms by fluorine in the aliphatic chain structure

650

651 Note 1 to entry: The term is used in the broader sense for per- and polyfluoroalkyl substances (PFAS), and
652 per- and polyfluorinated compounds (PFC) as well.

653

654 [Source: ISO 21675:2019, 3.1 (ISO, 2019c)]

655 **4.2.54 perfluoro sulfonic acid (PFSA)**

656 chemical compounds of the formula $C_nF_{(2n+1)}SO_3H$ and thus belong to the family of perfluorinated and
657 polyfluorinated alkyl compounds

658 **4.2.55 performance characteristics**

659 characteristics defining the ability of a test item (**4.2.74**) to operate as intended under given conditions
660 of use and maintenance

661 **4.2.56 performance degradation**

662 process leading to a significant change in the performance of the test item (**4.2.74**), typically characterised
663 by a change of properties, whether reversible or irreversible, or by a decay affected by environmental and
664 test conditions, proceeding over a period of time and comprising one or several steps that effect the test
665 item (**4.2.74**) to operate as intended, under given conditions of use

666 **4.2.57 performance test**

667 test intended to verify whether or to evaluate to which degree a test item (**4.2.74**) is able to accomplish
668 its performance characteristics (**4.2.55**)

669 **4.2.58 photovoltaic (PV) array**

670 two or more photovoltaic modules at one location that together provide a photovoltaic solar energy system

671

672 [Source: ISO 6707-3:2022, 3.3.7 (ISO, 2022a)]

673 **4.2.59 photovoltaic (PV) power**

674 technology that turns sunlight directly into electricity

675

676 [Source: ISO/IEC TR 15067-3-8:2020, 3.19 (ISO, 2020e)]

677 **4.2.60 platinum-group metals (PGM)**

678 group of six noble, precious metallic elements (ruthenium, rhodium, palladium, osmium, iridium, and
679 platinum) clustered together in the periodic table

680

681 Note 1 to entry: These transition metals are located in the d-block of the periodic table. They have
682 similar physical and chemical properties.

683 **4.2.61 proton exchange polymer membrane (PEM)**

684 polymer based membrane with cation (proton) conductivity which acts as an electrolyte (**4.2.36**) and a
685 separator between anode and cathode

686
687 Note 1 to entry: PEM is a cation exchange membrane exclusively in the acidic H⁺ form.

688
689 [Source: JRC EUR 30324 EN report, term 695 (Malkow *et al.*, 2021)]

690 **4.2.62 proton exchange membrane water electrolysis (PEMEL)**
691 electrolyser that employs a polymer with (proton) ion exchange capability as the electrolyte (**4.2.36**)

692
693 [Source: IEC 62282-8-102:2019, 3.1.26 (IEC, 2019b)]

694 **4.2.63 proton exchange membrane water electrolysis (PEMEL)**
695 electrolysis (**4.2.35**) that employs a proton exchange polymer membrane (**4.2.61**) as electrolyte (**4.2.36**)

696
697 [Source: JRC EUR 30324 EN report, term 696 (Malkow *et al.*, 2021)]

698 **4.2.64 principle of superposition**

699 principle that the time response to the sum of several input variables is the same as the sum of the time
700 responses caused by the individual input variables

701
702 Note 1 to entry: The principle of superposition includes the special case, that at multiplication of an
703 input variable by a constant factor the accompanying time response is multiplied by the same factor
704 (often called “principle of amplification”).

705
706 [Source: IEV 351-45-01]

707
708 Note 2 to entry: In electrochemical impedance spectroscopy (EIS) measurements, input variables are
709 current and voltage under galvanostatic conditions and potentiostatic conditions, respectively. Under
710 these conditions, the time responses are the resulting voltage and current.

711
712 Note 3 to entry: This principle is attributed to Ludwig Boltzmann (1844-1906) and John Hopkinson
713 (1849-1898).

714 **4.2.65 renewable energy**
715 energy obtained from a renewable energy source (**4.2.66**)

716
717 [Source: ISO/IEC 13273-2:2015, 3.1.6 (ISO and IEC, 2015b)]

718 **4.2.66 renewable energy source (RES)**
719 energy source not depleted by extraction as it is naturally replenished at a rate faster than it is extracted

720
721 [Source: ISO/IEC 30134-3:2016, 3.1.4 (ISO, 2016a)]

722 **4.2.67 reverse current**

723 flow of induced current in a commissioned AWE (**4.2.6**) stack during OCV operation (zero supply current)
724 given the electrical connections of a closed circuit made of the bipolar plates (**4.2.13**) with electronic
725 conduction and ionic conduction of the electrolyte (lye) solution in the manifolds of the stack

726 **4.2.68 smart grid**

727 electric power system that utilises information exchange and control technologies, distributed computing
728 and associated sensors and actuators for purposes such as:

- 729 - to integrate the behaviour and actions of the network users and other stakeholders,
730 - to efficiently deliver sustainable, economic and secure electricity supplies

731 [Source: IEV 617-04-13]

732
733 Note 1 to entry: Smart grids enable enhanced and automated monitoring and control of electricity
734 generation, transmission and distribution for added availability, reliability, efficiency, and cost-effective
735 operations.

736 **4.2.69 standard ambient temperature and pressure (SATP) conditions**

737 conditions of standard ambient pressure ($p^0 = 100$ kPa) and standard ambient temperature ($T^0 = 298,15$
738 K)

739 **4.2.70 stressing operating conditions**

740 operating conditions intentionally in excess of normal operating conditions exerted onto a test item
741 (4.2.74) which are likely to cause performance degradation (4.2.56) of the item during its operation

742 **4.2.71 supervisory control and data acquisition (SCADA)**

743 process control system generally used to control dispersed assets using centralised data acquisition
744 (4.2.23) and supervisory controls

745
746 [Source: ISO/IEC 27019:2017, 3.15 (ISO and IEC, 2017)]

747
748 Note 1 to entry: Systems operate with coded signals over communication channels with remote equipment
749 to acquire information about the status for display or recording functions and accessing process control
750 set points and current and historical online data.

751 **4.2.72 test protocol**

752 list of the steps to be followed in the test

753
754 [Source: ISO/IEC/IEEE 26513:2017, 3.141 (ISO et al., 2017)]

755
756 Note 1 to entry: Typically, test protocols describe the specific testing including TIPs (4.2.73) to be
757 set, monitored and reported in accordance with a test plan (4.2.76) which details their actual values and
758 TOPs (4.2.75) to be measured or calculated, analysed and reported as well as test cases and test profiles
759 to be executed employing test and measurement methods.

760 **4.2.73 test input parameter (TIP)**

761 parameter whose values can be set in order to define the test conditions of the test system including the
762 operating conditions of the test object

763
764 Note 1 to entry: TIPs have to be controllable and measurable. Values of TIPs are known before con-
765 ducting the test. TIPs can be either static or variable. Static TIPs stay constant and variable TIPs are
766 varied during the test.

767
768 [Source: IEC 62282-8-101, 3.1.33 (IEC, 2020c)]

769 **4.2.74 test item**

770 electrolyser (4.2.34) stack of type AWE (4.2.6), AEMWE (4.2.9) including AAEMWE, or PEMWE (4.2.62)

771 **4.2.75 test output parameter (TOP)**

772 parameter that indicates the response of the test system/test object as a result of variation of test input
773 parameters (4.2.73)

774
775 [Source: IEC 62282-8-101, 3.1.34 (IEC, 2020c)]

776
777 Note 1 to entry: Values of TOPs are unknown before conducting the test and are measured during
778 the test or calculated subsequently.

779 **4.2.76 test plan**

780 planning document detailing the principles, test methods, conditions, procedures and data quality required
781 to carry out testing and to produce test data

782
783 [Source: ISO 14050:2020, 3.4.19 (ISO, 2020b)]

784
785 Note 1 to entry: The test plan outlines the objective(s), purpose(s), requirements and strategy for testing
786 including the type of test(s), descriptions of test environments and conditions including TIP (4.2.73) set
787 point values, responsibility for the testing, the equipment and instrumentation for use in the testing as
788 well as the process for performing (work flow of testing) and documenting the test(s) (recording, analysing
789 and reporting of test results) and for handling test failure(s).

790 **4.2.77 uncertainty**

791 parameter, associated with the result of a measurement, that characterises the dispersion of the values
792 that could reasonably be attributed to the measurand

793
794 [Source: International Electrotechnical Vocabulary (IEV) 415-05-13]

795 **4.2.78 water electrolyser (WE) stack**

796 assembly of two or more electrochemical cells (**4.2.32**), separators, manifolds and a supporting structure
797 using DC electricity to generate hydrogen and heat by the electrolysis (**4.2.35**) of liquid water

798

799 Note 1 to entry: Alkaline water electrolyser (**4.2.6**) stacks and alkaline anion exchange polymer membrane
800 water electrolyser stacks employ alkaline solution rather than liquid water.

801 **4.2.79 water electrolyser (WE) system**

802 assembly of interrelated components of defined configuration with one or more water electrolyser stacks
803 (**4.2.78**) at its core, which delivers hydrogen

804

805 Note 1 to entry: A water electrolyser system can include components such as power supply terminals, fluid
806 connectors, compressors, storage vessels, piping, valves, pressure-relief devices, pumps, expansion joints,
807 gauges, cabling, and control, monitoring and safety subsystems including communication interfaces.

808 Note 2 to entry: A water electrolyser system can refer to a site, a facility at a site, or an installation at a
809 facility. A water electrolyser plant may contain multiple water electrolyser systems.

810 **4.2.80 wind power**

811 use of wind to provide mechanical power through wind turbines (**4.2.81**) to turn electric generators

812

813 [Source: ISO 6707-3:2022, 3.6.19 (ISO, 2022a)]

814 **4.2.81 wind turbine (WT)**

815 device that converts kinetic energy from the wind into electricity

816

817 [Source: ISO 6707-3:2022, 3.2.5 (ISO, 2022a)]

818 **4.3 Abbreviations and acronyms used**

819 A list of abbreviations and acronyms used in this report is appended, see page 65.

820 **4.4 Symbols used**

821 A list of symbols used in this report is appended, see page 69.

5 Description of test items

5.1 AWE stack

Figure 5.1 shows schematically the input and output streams of energy forms and substances of an AWE stack.

Figure 5.1: Schematic of the input and output streams (directional arrows) of energy forms (diamond shape) and substances (circular shape) of an AWE stack (rectangular shape); q and p represent flow rate and pressure, respectively. The thick line around the grey-shaded box denotes the stack boundary. The use of the grey colour indicates streams of secondary relevance in the context of accelerated stress testing.

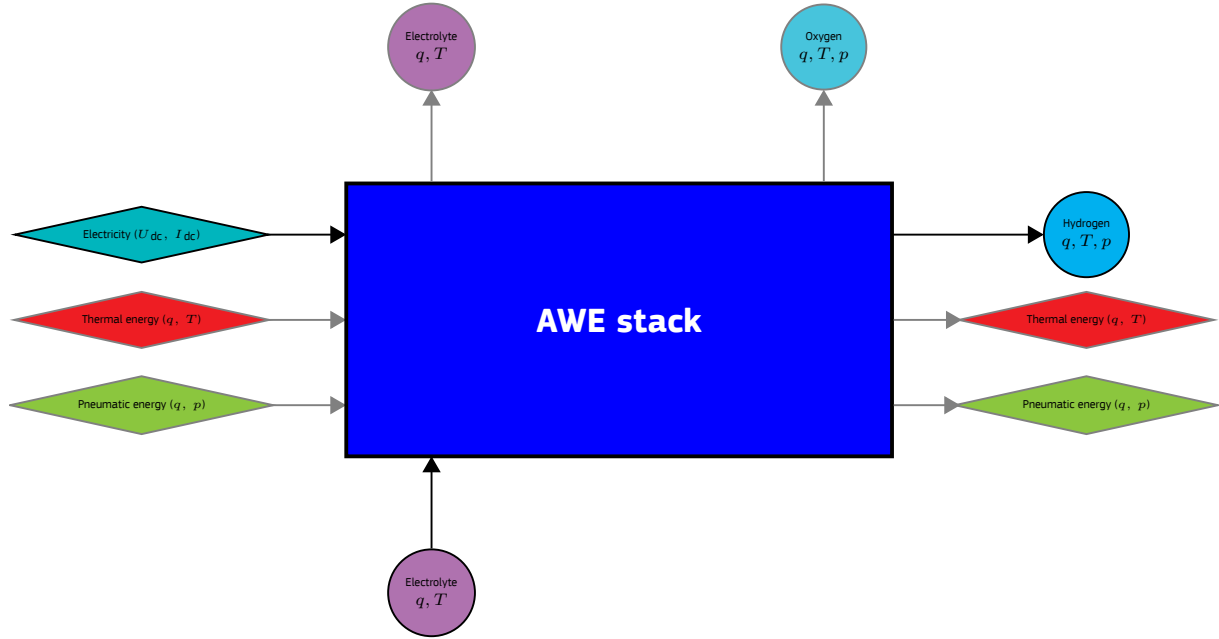

Source: JRC, 2023.

At its PoCs (current/voltage terminals and fluid inlets), the input energy streams to an AWE stack are

- **Electricity** in the form of electric energy, see equation (3.3.1a), by supplying DC power, see equation (3.3.1b),
- **Thermal energy** (E_{th}), if any, in the form of heat/cold:

$$E_{th} \text{ (kWh)} = P_{th} \text{ (kW)} \cdot t \text{ (h)} \text{ where} \quad (5.1.1a)$$

P_{th} is thermal power given by equation (5.1.1b) and t is the duration of heat/cold supply.

$$P_{th} \text{ (kW)} = \sum_i q_m^i \text{ (kg/s)} \cdot c_p^i \text{ (kJ/(kg K))} \cdot (T^i \text{ (K)} - T^0 \text{ (K)}); \quad (5.1.1b)$$

q_m^i , c_p^i and T^i are mass flow rate, specific heat capacity at constant pressure and temperature of fluid i , respectively. On input, the heat transfer fluid i (input substance stream) is the aqueous electrolyte.

- **Pneumatic energy** (E_{compr}) is only relevant for pressurised stacks:

$$E_{compr} \text{ (kWh)} = P_{compr} \text{ (kW)} \cdot t \text{ (h)} \text{ where} \quad (5.1.2a)$$

P_{compr} is the power of compression given by equation (5.1.2b) and t is the duration of pressurised stack operation.

$$P_{compr} \text{ (kW)} = \sum_j \left(\frac{\gamma^j}{\gamma^j - 1} \right) \frac{\bar{Z}^j \cdot R_g \text{ (kJ/(mol K))} \cdot T^0 \text{ (K)} \cdot q_n^j \text{ (mol/h)}}{3600 \text{ (s/h)}} \left(\left(\frac{p^j \text{ (kPa)}}{p^0 \text{ (kPa)}} \right)^{\frac{\gamma^j - 1}{\gamma^j}} - 1 \right); \quad (5.1.2b)$$

R_g , \bar{Z}^j , q_n^j and p^j are universal gas constant, average compressibility factor, molar flow rate and pressure of fluid j , respectively. The isentropic expansion factor of fluid j is calculated as follows

$$\gamma^j = \frac{c_p^j \text{ (kJ/(kg K))}}{c_v^j \text{ (kJ/(kg K))}}; \quad (5.1.2c)$$

c_p^j and c_v^j are specific heat capacity at constant pressure and constant volume of fluid j , respectively. For a pressurised stack, the pneumatic fluids j (output substance streams) are hydrogen and oxygen.

At fluid outlets, the output energy and substance streams from an AWE stack are

- Thermal energy carried by heat transfer fluids:
 - aqueous electrolyte,
 - hydrogen and
 - oxygen,
- Pneumatic energy carried by compressible fluids:
 - hydrogen and
 - oxygen,
- Hydrogen at the cathode and
- Oxygen and water at the anode.

5.2 AEMWE stack

Figure 5.2 shows schematically the input and output streams of energy forms and substances of an AEMWE stack.

Figure 5.2: Schematic of the input and output streams (directional arrows) of energy forms (diamond shape) and substances (circular shape) of an AEMWE stack (rectangular shape). The thick line around the grey-shaded box denotes the stack boundary. The use of the grey colour indicates streams of secondary relevance in the context of accelerated stress testing.

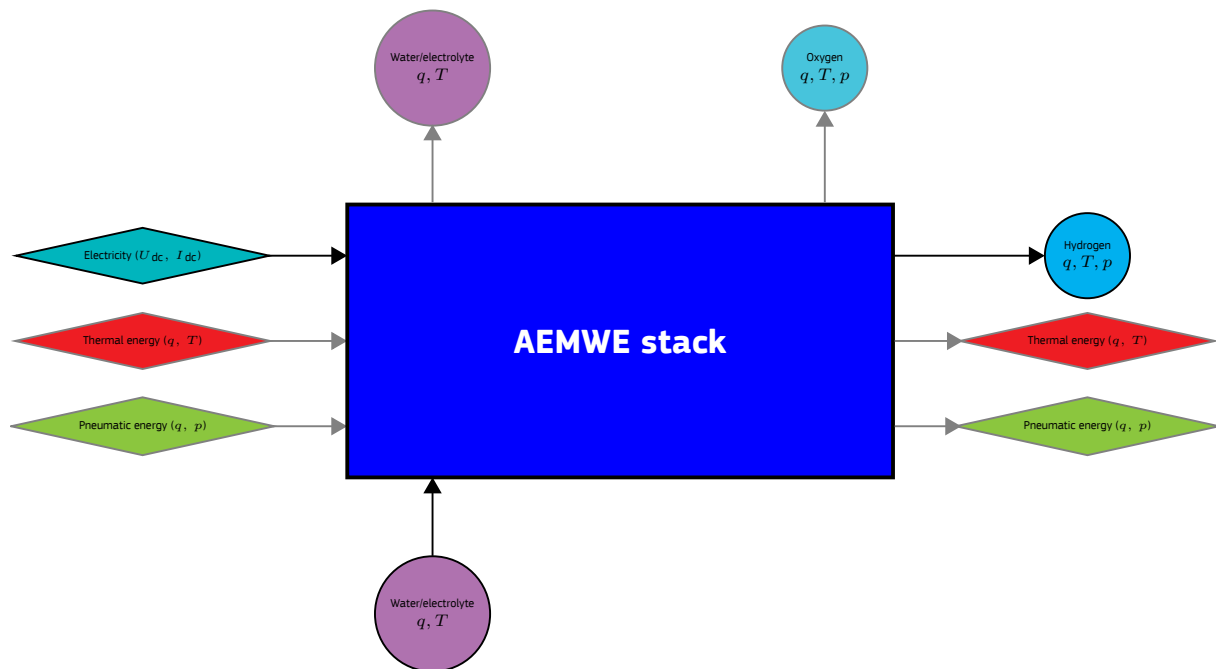

Source: JRC, 2023.

At its PoCs (current/voltage terminals and fluid inlets), the input energy streams to an AEMWE stack are

- **Electricity** in the form of electric energy, see equation (3.3.1a), by supplying DC power, see equation (3.3.1b),

- 873 • **Thermal energy**, see equation (5.1.1a), if any, in the form of heat/cold where on input the heat transfer
874 fluid i (input substance stream) is liquid water for AEMECs and aqueous electrolyte for AAEMECs.
- 875 • **Pneumatic energy**, see equation (5.1.2a), which is only relevant for pressurised stacks where the pneu-
876 matic fluids j (output substance streams) are hydrogen and oxygen.

877 At fluid outlets, the output energy and substance streams from an AEMWE stack are

- 878 • Thermal energy carried by heat transfer fluids:
 - 879 - liquid water for AEMECs and aqueous electrolyte (lye) for AAEMECs,
 - 880 - hydrogen and
 - 881 - oxygen,
- 882 • Pneumatic energy carried by compressible fluids:
 - 883 - hydrogen and
 - 884 - oxygen,
- 885 • Hydrogen at the cathode and
- 886 • Oxygen and water/lye at the anode.

887 5.3 PEMWE stack

895 Figure 5.3 shows schematically the input and output streams of energy forms and substances of a PEMWE
896 stack.

888 **Figure 5.3:** Schematic of the input and output streams (directional arrows) of energy forms (diamond shape)
889 and substances (circular shape) of a PEMWE stack (rectangular shape). The thick line around the
890 grey-shaded box denotes the stack boundary. The use of the grey colour indicates streams of
892 secondary relevance in the context of accelerated stress testing.

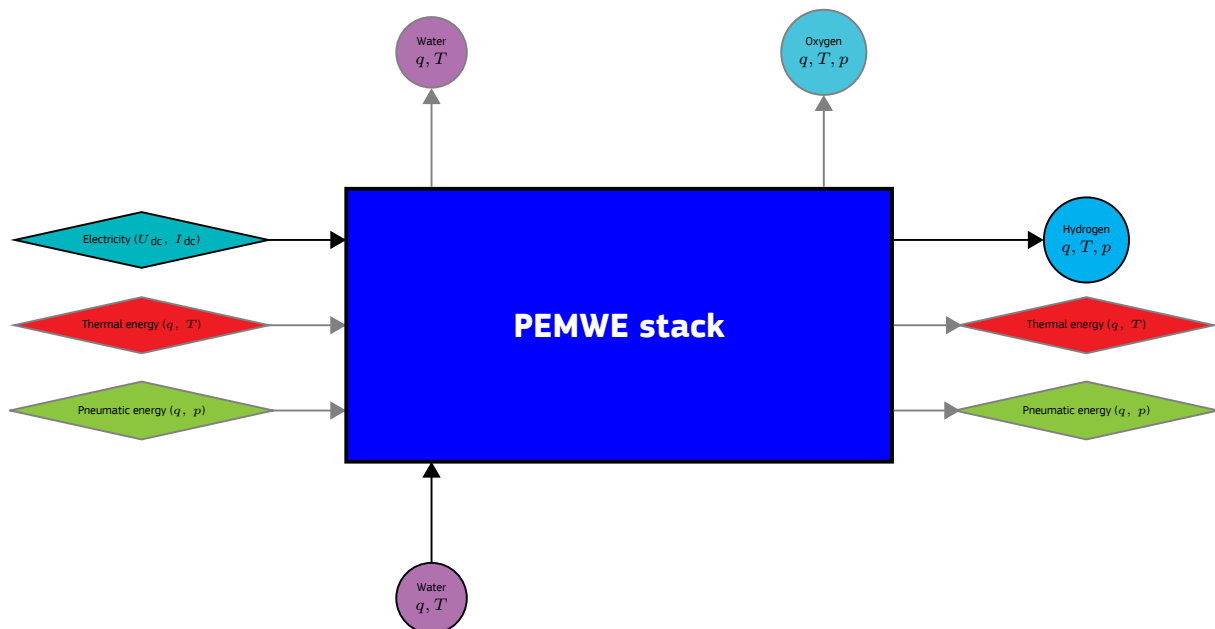

893

894

Source: JRC, 2023.

897 At its PoCs (current/voltage terminals and fluid inlets), the input energy streams to a PEMWE stack are

- 898 • **Electricity** in the form of electric energy, see equation (3.3.1a), by supplying DC power, see equa-
899 tion (3.3.1b),
- 900 • **Thermal energy**, see equation (5.1.1a), if any, in the form of heat/cold where on input the heat transfer
901 fluid i (input substance stream) is liquid water.

- 902 ● **Pneumatic energy**, see equation (5.1.2a), which is only relevant for pressurised stacks where the pneu-
903 matic fluids j (output substance streams) are hydrogen and oxygen.
- 904 At fluid outlets, the output energy and substance streams from a PEMWE stack are
- 905 ● Thermal energy carried by heat transfer fluids:
- 906 - liquid water,
907 - hydrogen and
908 - oxygen,
- 909 ● Pneumatic energy carried by compressible fluids:
- 910 - hydrogen and
911 - oxygen,
- 912 ● Hydrogen and water due to electro-osmosis (see section 3.1) at the cathode and
913 ● Oxygen at the anode.

6 Proposal for AST protocols

6.1 General

A test campaign for assessing the performance degradation of WE stacks under specified test and operating conditions may have different objectives such as

- Determining qualitatively and/or quantitatively one or another identified degradation phenomenon including interactions (coupling) among different and possibly simultaneously occurring phenomena for a given set of WEC materials in a particular stack configuration of known design,
- Identifying or verifying hypothesised degradation mechanisms associated with one or more known phenomena occurring for a set of WEC materials in given stack,
- Evaluating the performance and durability of improved or newly developed materials for WEC components deployed in a representative stack design and configuration,
- Checking on suitable stack designs and configurations as well as
- Identifying potentially detrimental operating conditions and modes of operation as well as optimising operation modes of a stack in a given WE system deployed in a particular application.

As for any test campaign, an AST campaign on WE stacks follows a test programme with a test plan (section 6.6) and schedule to conduct tests according to protocols describing precisely what type of tests, whether performance tests (4.2.57) or durability tests (4.2.28), should be carried out under which test and operating conditions (section 6.3) and how tests should be performed, in which order, when and for how long or how often. It includes post-processing and presentation of the test results (section 7) as well as their reporting (Annex B).

What makes an AST campaign different from a test campaign testing the durability of WE stacks, is that the former test campaign aims to significantly shorten the time required for stack testing in order to save cost on R&D of WE stacks. Alternatively, it is to test a greater variety of WEC materials and stacks in the same amount of time using the available test hardware and equipments more effectively. It seeks at an earlier demonstration and market entry of the developed WE stacks and eventually accelerates their commercialisation. For this reason, WE stacks are operated for a short time under operating conditions different to their normal operating conditions in an attempt to trigger similar performance degradation mechanism(s) as occur for longer stack exposures. It leads inevitably to more and higher transient operation of WE stacks primarily supplied by fluctuating RES electricity with a higher number of and more frequent changes in current or voltage (including start/stop (ON/OFF) operation) as would occur under real-life operating conditions.

In an AST campaign, available real-world operation profiles of RES-derived power (section 6.8.2) may be compressed in duration by a compression factor (f_{compr}) (4.2.19) and combined to obtain simulated duty cycles for dynamic operation of a WE stack undergoing accelerated stress testing. Additional stress is by setting other operating parameters especially stack operating temperature (T_{stack}) and differential (anode-to-cathode) pressure to their extreme values but not out of the range specified by the stack manufacturer to avoid dysfunction or destruction of the WE stack. As well, additional stress can be applied to a WE stack when deliberately adding known contaminants in sufficient quantities to the lye solution in AWE and AAEMWE and to liquid water in AEMWE and PEMWE but not too high in amount and combination to risk dysfunction or destruction of the stack.

However, the operation of the WE stacks (section 5) shall be in accordance with applicable safety requirements (Annex A) and the manufacturer's instructions. WE stacks should not be subjected to test and operating conditions jeopardising safety or risk the dysfunction or destruction of the stack. Then, the selection of the stressing operating conditions (section 6.5) and of their values and ranges shall be within the specification of the stack manufacturer. Also, the test equipment used shall be suitable to apply the stressing operating conditions to the WE stack.

When an aspect of performance degradation of a WE stack is initially not or insufficiently known, an iterative and possibly step-wise approach may be applied where one condition and mode of operation is varied within a reasonable parameter range considering the limiting operating conditions specified by the stack manufacturer. Progressively, more than one such condition or operation mode may be changed in order to arrive on a set of suitable stressing operating conditions and mode of operation of a WE stack. The established conditions and operating mode are for use in subsequent AST campaigns.

Note, in comparison to presently identified stressing operating conditions and mode of operation suggested in available testing protocols (Aricò *et al.*, 2013, Aricò *et al.*, 2016, Aricò *et al.*, 2018, Strataki, 2018, Stiber *et al.*, 2020, Mennemann *et al.*, 2021, Aricò *et al.*, 2020, Fouda-Onana, 2020), the various challenges experienced by WE stacks (section 3.4) will likely entail seeking to re-establish such conditions and modes of operation when testing improved or newly developed materials in one or another WEC component of a WE stack. Also, the design and configuration of stacks may adapt to changes in the set-up and operation of WE system in response

969 to these challenges. An ever increasing share of VRE in the electricity grid across Europe and ongoing market
970 developments in exceedingly and diverse P-to-H₂ and H₂-to-I applications worldwide may also lead to stack
971 adaptations.

972 The testing of WE stacks under given test conditions (section 6.3) consists of executing, usually at their
973 beginning-of-life (BoL), all or selected types of tests according to a defined test plan (section 6.6). BoL of a
974 stack shall be the start of its first-time operation following complete conditioning according to manufacturer
975 instructions. Performance tests (section 6.7) of a stack at BoL are followed by durability tests (section 6.9)
976 conducted for a prescribed period of use of the stack (section 6.9.2) employing application-oriented operation
977 profiles of power, current or voltage (section 6.8.2) as appropriate for the intended use of the stack (section 6.9.3).

978 Optionally, performance tests can be executed intermittently at specified intervals to assess how the stack
979 has maintained or altered its performance characteristics⁽²⁴⁾. Performance tests are mandatory at the end of
980 the test campaign to evaluate the final degree of stack degradation using suitable KPIs (section 6.10). Changes
981 in the performance characteristics of stacks are usually also presented graphically versus the total test duration
982 or the number of performed operation profiles or sequence(s) of operation profiles (section 7).

983 The test plan (section 6.6) may require to intermittently perform safety checks (Annex A) on the stack. Testing
984 shall not continue for stacks unsafe to operate.

985 **6.2 Measurement techniques**

986 The test equipment, measuring instruments and measurement methods shall conform to relevant standards
987 (e.g. IEC 61010-1:2010+AMD1:2016 CSV (IEC, 2016)), test methods and procedures or best testing practices.
988 Instruments shall be calibrated in accordance with applicable standard(s), measurement method(s) or proced-
989 ure(s) as recommended by the manufacturer of the stack to meet the targeted uncertainty (**4.2.77**) of the
990 concerned test parameter, whether TIP (**4.2.73**) or TOP (**4.2.75**). The measurement set-up shall be documented.
991 Calibration records and certificates of the measuring instruments should be available. Guidance on how to
992 carry out an uncertainty analysis of the test results is provided by the Guide to the expression of uncertainty in
993 measurement (GUM) (JCGM, 2008, JCGM, 2009, JCGM, 2020).

994 **6.3 Test conditions**

995 The test conditions with permissible variations are

- 996 • environmental conditions of the immediate surrounding (ambient) of the item under test: air (composition,
997 velocity, pressure, temperature, humidity), salinity, ultraviolet (UV) radiation and other (weather) conditions,
998 see clause 4.4 of IEC 60204-1:2016+AMD1:2021 CSV (IEC, 2021a).
- 999 • actual operating conditions and modes of WE stack operation: start-up (hot and cold), shut-down, emer-
1000 gency stop and quiescence (standby).

1001 They shall be defined prior to testing in accordance with the purpose(s) and objective(s) of the test campaign
1002 and be in conformity with the specification of the stack as provided by the manufacturer.

1003 However, the TIPs used in the various performance and durability tests constitute the operating conditions
1004 of the stack. In the test plan (section 6.6), the individual set point values of these TIPs shall be listed per test to
1005 be performed. The test plan should also list and name the TOPs (test results) to be measured or calculated per
1006 each test.

1007 Further, while the inlet flow rates, temperatures and compositions of liquid feeds (lye and water) are TIPs set
1008 (operating conditions), the electrode gas pressures and outlet temperatures are TOPs needing regulation. Other
1009 set of operating conditions to be set are stack power (P_{stack}), stack current (I_{stack}) or stack voltage (U_{stack}).

1010 In the first case, stack power is the TIP set, the stack current and DC voltage are measured TOPs. In the
1011 second case, stack current is the TIP set. The stack voltage is a TOP measured. In the third case, stack voltage
1012 is the TIP set. The stack current is the TOP measured. In both latter cases, the stack power is a derived TOP to
1013 be calculated.

1014 **6.4 Reference test conditions**

Reference test conditions are agreed prior to testing to facilitate comparison of test results⁽²⁵⁾. That is, reference
test conditions are defined in agreement with manufacturer specification to assess the performance degradation

⁽²⁴⁾ The operation regime applied to the stack during a performance test can affect its degradation rate.

⁽²⁵⁾ For the three WEL technologies (AEL, AEMEL and PEMEL), the strategic research and innovation agenda 2021-2027 of the Clean Hydrogen Partnership for Europe (SRIA) states 2024 and 2030 KPI targets for current density and hydrogen pressure but not for stack operating temperature (lye/water output temperature); see online at https://www.clean-hydrogen.europa.eu/knowledge-management/sria-key-performance-indicators-kpis_en.

1015
1016
1017
1018
1019
1020
1021
1022

of WE stacks upon durability tests (section 6.9) conducted under stressing operating conditions (section 6.5) as appropriate, by means of polarisation curve measurements (section 6.7.11) and EIS measurements (section 6.7.12). Table 6.1 provides reference operating conditions recommended for typical WE stacks of type AWE, AEMWE and PEMWE. For a test campaign aiming at a direct comparison of the three LTWE technologies or at a comparison of one stack technology versus another stack technology, the reference values of stack current density and stack operating temperature may be chosen to be the same.

Table 6.1: Recommended reference operating conditions for typical WE stacks (AWE, AEMWE and PEMWE)

Description	Unit	Symbol	AWE	AEMWE	PEMWE
Stack current density ⁽¹⁾	A/cm ²	J_{stack}	0,4 (± 2,5 %)	1,0 (± 1 %)	2,0 (± 0,5 %)
Stack operating temperature ⁽²⁾	K	T_{stack}	353,15 (±2 K)	333,15 (±2 K)	353,15 (±2 K)
Hydrogen pressure ⁽³⁾	kPa(g)	p_{H_2}	100 (±2 %) (4)	100 (±2 %)	100 (±2 %) (4)

1023 *Note:* The test plan (section 6.6) may list other conditions including ambient environmental conditions of the WE stack other than standard
1024 ambient temperature and pressure (SATP) conditions (4.2.69); see, for example, clause 5.2.3.1 of ISO 22734:2019 (ISO, 2019a).

1025 ⁽¹⁾ This value should correspond to the maximum current density at BoL.

1026 ⁽²⁾ Unless otherwise agreed or specified by the manufacturer, the sensor (*e.g.* thermocouple) position to determine the stack operating
1027 temperature should be at the center of the tubing where lye/water is put out by the WE stack close to its outlet.

1028 ⁽³⁾ The gauge pressure of hydrogen is measured at the outlet of the WE stack, preferably upon removal of residual liquid (lye or water).
1029 Gauge pressure is chosen to allow comparison when testing is conducted at sites having different atmospheric pressure levels. Balanced
1030 pressure or differential pressure operation of the stack shall be reported.

1031 ⁽⁴⁾ The SRIA anticipates a pressure of hydrogen of 3 MPa for the AEL and PEMEL technologies, see footnote 25. This pressure level is not
1032 selected as not all test equipment may allow testing at such pressure.

1033 *Source:* JRC, 2023

1034 A WE stack should first be subjected to testing at reference test conditions before proceeding to testing under
1035 other specified test conditions including stressing operating conditions (section 6.5). Particularly, this regards
1036 polarisation curve measurements (section 6.7.11) and EIS measurements (section 6.7.12) at beginning-of-test
1037 (BoT) and at end-of-test (EoT) when WE stacks should again be tested under these reference test conditions to
1038 assess their overall performance degradation in the test campaign.

1039 6.5 Stressing operating conditions

1040 Major stressing operating conditions for WE stacks are (Tsotridis and Pilenga, 2021)

1041 • *High current density operation:* This concerns operation at stack current densities in excess of the recommen-
1042 ded value (see Table 6.1), for example, at up to 200 % of the recommended value.

1043 • *Dynamic electric operation:* This concerns variable electric power, direct current or DC voltage (including fre-
1044 quent ON/OFF operation) (Sayed-Ahmed *et al.*, 2024) employing simulated operation profiles (Alia *et al.*,
1045 2019, Allidières *et al.*, 2019, Aßmann *et al.*, 2020, Tsotridis and Pilenga, 2021, Malkow and Pilenga, 2023b, Re-
1046 issner *et al.*, 2020), or RES-derived "real-world" operation profiles (section 6.8.2). For AWE stacks, OFF
1047 operation (zero supply current or OCV conditions), the phenomenon of the flow of a reverse current (4.2.67)
1048 occurs which leads to materials oxidation at the negatively charged cathode and materials reduction at the
1049 positively charged anode on the respective biP side (Haleem *et al.*, 2021).

1050 • *AC ripple:* This concerns current (or voltage) fluctuations due to non-optimum AC/DC conversion, which are
1051 inevitable in real converters, superimposed onto DC (or DC voltage) supplied to the stack (Parache *et al.*,
1052 2022).

1053 • *Stack operating temperature:* The stack operating temperature influences the thermal-neutral voltage of the
1054 stack and the overvoltages as well as temperature-activated reaction kinetics at the electrodes.

1055 • *Pressure:* This concerns especially anode-to-cathode differential pressure of the stack. For example, pressure
1056 cycling can be performed within the range of 60 % and 100 % of the nominal pressure (as specified by
1057 the manufacturer) or beyond nominal pressure to test the mechanical integrity of the stack. For operational
1058 safety, the stack may intermittently be subject to leak testing to identify significant external and internal
1059 leaks.

1060 • *Lye/water inlet flow rate:* Too low lye/water inlet flow rates may result in insufficient wetting, risking dry active
1061 area and a reduction in gas bubble removal which could result in hotspots and overvoltage increases. Too
1062 high lye/water inlet flow rates could accelerate catalyst loss due to dissolution/erosion effects.

1063 • *Lye/water impurities*: This concerns deliberate additions of calcium, copper, iron, potassium, magnesium,
1064 sodium, nickel, zinc, chloride and carbonate ions (dissolved CO₂) to mainly affect IEM capability and catalyst
1065 activity (Becker *et al.*, 2023). Also, organics stemming from BoP components or products of in-stack materials
1066 deterioration, which are introduced to the stack by re-circulated lye/water, may deliberately be added.

1067 Considering the specification of the stack and the test equipment capabilities, the test plan (section 6.6) shall
1068 specify the values and ranges of these stressing operating conditions including the compression factor applied
1069 to the original operation profile. The compression factor is the ratio of the duration of the compressed operation
1070 profile (t_{compr}) to the duration of the original operation profile (t_{origin}) calculated as follows

$$1071 \quad f_{\text{compr}} = \frac{t_{\text{compr}}(\text{h})}{t_{\text{origin}}(\text{h})}, \quad 0 < f_{\text{compr}} < 1. \quad (6.5.1)$$

1072 The actual choice of a compression factor shall be such that the test equipment used can readily apply the
1073 intended dynamic operation of the stack and the ramp rates resulting from the simulated duty cycle(s) do not
1074 exceed those specified by the stack manufacturer, if any.

1075 In addition to accelerated stress testing of WE stacks, accelerated lifetime testing of the same type of stack
1076 may be conducted employing the original operation profile (section 6.8.2) while applying the same stack oper-
1077 ating temperature and differential pressure without deliberately adding lye/water impurities. Note, performing
1078 accelerated lifetime testing of stacks as part of a test campaign using a suitable DoE (4.2.25) methodology
1079 along with physics-based modelling will assist in

1080 - Identifying ranges of aggravated test conditions (stressing operating conditions) representative of the
1081 targeted application and duty cycle in real-world stack operation which do not significantly alter the
1082 interdependency or eminence of intrinsic degradation mechanisms and

1083 - Deriving robust AST transfer functions to correlate accelerating factors (stressing operating conditions) with
1084 the occurrence or amplification of performance degradation in stacks and eventually, to reliably quantify
1085 rates of performance degradation allowing to predict durability under real-world conditions which can
1086 contemporaneously or sequentially be combined for evaluating various relevant stack operation modes.

1087 This is especially useful to lower overall R&D cost of WE stacks as test durations could significantly be reduced.

1088 **6.6 Test plan**

1089 The test plan shall take into account

1090 (a) the manufacturer specification and instructions (*e.g.* maximum voltage, pressure and anode-to-cathode
1091 differential pressure, stack operating temperature, range of heating/cooling rates and electrode gas
1092 compositions, etc),

1093 (b) an activation/conditioning procedure for initial stack operation upon manufacture, refurbishment or pro-
1094 longed non-operation (Lickert *et al.*, 2023, Tomić *et al.*, 2023),

1095 (c) the test conditions: reference test conditions (section 6.4) and stressing operating conditions (section 6.5),

1096 (d) the measurement techniques and instrumentation (section 6.2),

1097 (e) the test type (section 6.7 and section 6.9), sequence, frequency, duration and operation profiles,

1098 (f) the DAQ with number and logging rates of the data points ⁽²⁶⁾,

1099 (g) re-start procedure upon unintended test interruptions other than pre-mature stack failure (*i.e.* test equip-
1100 ment break down, emergency stops, power supply failure, etc),

1101 (h) one or more KPIs, whether measured or derived TOPs, as a result of performance tests,

1102 (i) one or more test stop criteria to end testing to prevent unintended failure or destruction of the stack and

1103 (j) the post-processing of test results, data reduction and uncertainty analysis (coverage factor of 2) (JCGM,
1104 2008) according to GUM (JCGM, 2009).

1105 One or more KPIs shall be defined to assess the performance and durability of the test item. For this purpose,
1106 TIPs and TOPs should be specified to obtain KPIs as functions of such parameters; for example,

⁽²⁶⁾ Considering the duration of the individual tests and the expected standard uncertainty in the measurements, different numbers, ranges and data logging rates may apply to performance tests (section 6.7) and durability tests (section 6.9).

- 1107 - TIPS:
- 1108 • input electric power ($P_{el,in}$) (section 6.7.1), input current (I_{in}) (section 6.7.2) or input voltage (U_{in})
 - 1109 (section 6.7.3) to the stack,
 - 1110 • input temperature of lye (T_{in}^{lye}) to AWE and AAEMWE stacks and
 - 1111 • input water temperature (T_{in}^w) to PEMWE and AEMWE stacks.

- 1112 - TOPs:
- 1113 • stack operating temperature (T_{stack}),
 - 1114 • output pressure of hydrogen (p_{H_2}) and
 - 1115 • temperature of hydrogen (T_{H_2}) generated by the stack.

1116 Environmental conditions other than SATP conditions may also be considered; for example, conditions likely to
 1117 be experienced at intended installation sites of WE systems.

1118 Consistent with the test campaign purpose(s) and objective(s), the test plan should specify the test methods
 1119 and measurement techniques employed where standards, testing procedures and manufacturer's instructions
 1120 provide different possibilities. The test plan may also list (micro-structural) characterisation methods, for
 1121 example, to perform post-test analysis of stack materials to gain more insight into the obtained test results.

1122 **6.7 Performance tests**

1123 **6.7.1 Input electric power**

1124 The input electric power to a WE stack shall be determined in accordance with clause 5.2.1 of ISO 16110-
 1125 2:2010 (ISO, 2010b).

1126 **6.7.2 Input direct current**

1127 For a specified DC voltage set, the input direct current to a WE stack shall be determined from electric power
 1128 measurements (section 6.7.1). The input direct current is the measured input electric power divided by the
 1129 specified DC voltage.

1130 **6.7.3 Input DC voltage**

1131 For a specified direct current set, the input DC voltage applied to a WE stack shall be determined from electric
 1132 power measurements (section 6.7.1). The input DC voltage is the measured input electric power divided by the
 1133 specified direct current.

1134 **6.7.4 Input thermal power**

1135 The input thermal power ($P_{th,in}$) to a WE stack conveyed by heat transfer fluid(s), if any, shall be determined in
 1136 accordance with clause 5.2.2 of ISO 16110-2:2010 (ISO, 2010b).

1137 **6.7.5 Input power of compression**

1138 The input power of compression ($P_{comp,in}$) to a WE stack conveyed by pneumatic fluid(s), if any, shall be
 1139 determined in accordance with clause 5.2.2 of ISO 16110-2:2010 (ISO, 2010b).

1140 **6.7.6 Response time and ramp energy**

1141 Especially for delivering grid balancing services by electrolyzers (Allidières *et al.*, 2019), the response time
 1142 (t_{resp}) of a WE stack to a given positive or negative ramp rate of input electric power, input direct current
 1143 or input DC voltage (section 6.6) should be determined in accordance with clause 5.6.1 of IEC 62282-8-
 1144 201:2020 (IEC, 2020d). Ramp rates shall be consistent with the manufacturer's instructions. In addition to
 1145 response time, the ramp energy (E_{ramp}) should be determined in accordance with clause 14.6.3.2 of IEC 62282-
 1146 3-201:2017+AMD1:2022 CSV (IEC, 2022) where by analogy, reference to fuel cell (FC) is replaced by water
 1147 electrolyser.

1148 The response time and ramp energy shall be recorded separately for positive and negative ramps in the test
 1149 report (Annex B). The test plan shall specify appropriate indices to be added to t_{resp} and E_{ramp} to distinguish
 1150 between different ramps, whether positive and negative. The state prior to ramping may include cold start
 1151 (4.2.17) and hot start (4.2.41).

1152 The determination of response time and ramp energy should at least be at BoT and EoT. It is for assessing
 1153 whether or not changes in the ability of a WE stack to respond as intended to variations in input electric power
 1154 (input direct current or input DC voltage) occurred due to durability testing of the stack (section 6.9).

1155 **6.7.7 Measurements of fluid feeds**

1156 For AWE and AAEMWE stacks, the pH value and the electrical conductivity (σ_{el}) of the alkaline solution (KOH
 1157 electrolyte) entering the stack shall, by analogy to water, be determined in accordance with clauses 7.1 and 7.2
 1158 of ISO 3696:1987 (ISO, 1987), respectively.

1159 For AEMWE and PEMWE stacks, the pH value and the electrical conductivity of the feed water to the stack shall
 1160 be determined in accordance with ISO 10523:2008 (ISO, 2008) and ISO 7888:1985 (ISO, 1985), respectively.

1161 **6.7.8 Hydrogen output rate and quality**

1162 The product gas output rate, also known as product gas molar flow rate ($q_{n,out}$) of the WE stack, shall be
 1163 determined in accordance with clause 5.2.11.1 of ISO 22734:2019 (ISO, 2019a). From the product gas molar
 1164 flow rate, the hydrogen output rate, also known as molar flow rate of hydrogen (q_{n,H_2}), shall be calculated as
 1165 follows

$$1166 \quad q_{n,H_2} \text{ (mol/h)} = x_{n,H_2} \text{ (mol/mol)} \cdot q_{n,out} \text{ (mol/h)}; \quad (6.7.1)$$

1167 x_{n,H_2} is the molar concentration of hydrogen in the product gas to be determined by gas analysis in accordance
 1168 with clause 5.2.2.2 of ISO 16110-2:2010 (ISO, 2010b). From the molar flow rate of hydrogen, the volumetric
 1169 flow rate of hydrogen (q_{V,H_2}) generated under SATP conditions is calculated as follows

$$1170 \quad q_{V,H_2} \text{ (m}^3\text{/h)} = q_{n,H_2} \text{ (mol/h)} \cdot V_{m,H_2} \text{ (m}^3\text{/mol)}; \quad (6.7.2)$$

1171 $V_{m,H_2} \approx 24,79 \cdot 10^{-3} \text{ m}^3\text{/mol}$ is the molar volume of hydrogen under SATP conditions⁽²⁷⁾. The hydrogen output
 1172 quality of a WE stack other than the molar concentration of hydrogen in the product gas, in particular, humidity,
 1173 shall be determined in accordance with clause 5.2.11.2 of ISO 22734:2019 (ISO, 2019a).

1174 Note, neglecting gas crossover and leakages in the stack, the theoretical volumetric flow rate of hydrogen
 1175 generated under SATP conditions can be calculated as follows

$$1176 \quad q_{V,H_2}^{\text{theo}} \text{ (m}^3\text{/h)} = \frac{V_{m,H_2} \text{ (m}^3\text{/mol)} \cdot I_{dc} \text{ (A)}}{z \cdot F \text{ (C/mol)}} \cdot 3600 \text{ s/h}; \quad (6.7.3)$$

1177 $F = 96485,3321 \text{ C/mol}$ is Faraday constant and z is the number of electrons exchanged in the WEC reactions
 1178 (3.1.2), (3.1.3) or (3.1.4). The mass flow rate of hydrogen (q_{m,H_2}) generated by a WE stack related to SATP
 1179 conditions is calculated as follows

$$1180 \quad q_{m,H_2} \text{ (kg/h)} = q_{n,H_2} \text{ (mol/h)} \cdot m_{H_2} \text{ (kg/mol)}; \quad (6.7.4)$$

1181 $m_{H_2} \approx 2,02 \cdot 10^{-3} \text{ kg/mol}$ is the molar mass of hydrogen under SATP conditions⁽²⁸⁾.

1182 **6.7.9 Oxygen output rate and concentration**

1183 The oxygen output rate, also known as molar flow rate of oxygen (q_{n,O_2}) of the WE stack, shall be determined in
 1184 accordance with clause 5.2.11.1 of ISO 22734:2019 (ISO, 2019a). The molar concentration of oxygen (x_{n,O_2}),
 1185 shall be determined in accordance with clause 5.2.11.2 of ISO 22734:2019 (ISO, 2019a).

1186 **6.7.10 Water quality measurements**

1187 For AEMWE and PEMWE stacks with materials containing fluorine (F), PFAS and polycyclic aromatic hydrocarbons
 1188 (PAH) such as membranes, coatings, sealants, etc, the quality of the water entering and exiting the stack should
 1189 be determined regarding

1190 (a) fluoride concentration (c_F) in accordance with ISO 10359-1:1992 (ISO, 1992), ISO 10359-2:1994 (ISO,
 1191 1994), ISO 10304-1:2007 (ISO, 2007), ISO/TS 17951-1:2016 (ISO, 2016b), ISO/TS 17951-2:2016 (ISO,
 1192 2016b) or ISO/TS 15923-2:2017 (ISO, 2017b), as appropriate.

⁽²⁷⁾ At a temperature of 273,15 K and a pressure of 101,3 kPa, the molar volume of hydrogen is $V_{m,H_2} \approx 22,41 \cdot 10^{-3} \text{ m}^3\text{/mol}$.

⁽²⁸⁾ The mass of deuterium and tritium as hydrogen isotopes are not considered due to their negligible natural abundance.

1193 (b) PFAS concentration (c_{PFAS}) in accordance with ISO 21675:2019 (ISO, 2019c) or any other suitable analysis
1194 technique ⁽²⁹⁾, as feasible.

1195 (c) PAH concentration (c_{PAH}) in accordance with ISO 17993:2002 (ISO, 2002), ISO 7981-1:2005 (ISO, 2005a),
1196 ISO 7981-2:2005 (ISO, 2005b) or ISO 28540:2011 (ISO, 2011b), as appropriate.

1197 The content of fluoride, PFAS and PAH in the water on stack inlet shall be subtracted from the respective content
1198 at stack outlet ⁽³⁰⁾. Upon subtracting any fluoride inlet content from that at stack outlet, the occurrence of
1199 fluoride in the water exiting the stack as an end product of the decomposition of fluoropolymers is conclusive
1200 evidence for the performance degradation of the stack by materials deterioration. Also, upon applying a similar
1201 subtraction procedure, the occurrence of PFAS and PAH in the exit water of a stack as fragments of partially
1202 decomposed polymers is likewise conclusive evidence for the performance degradation of the stack by materials
1203 deterioration. The identified type of fragments along with their analysed quantities may assist in determining
1204 the pathways of material deterioration to gain useful insight into the performance degradation of stacks.

1205 Especially for WE stacks tested using ion impurities in water as stressing operating conditions (section 6.5),
1206 the quality of the water entering and exiting the stack shall be determined regarding

1207 - calcium concentration (c_{Ca}) in accordance with ISO 6058:1984 (ISO, 1984a), ISO 7980:1986 (ISO, 1986a),
1208 ISO 14911:1998 (ISO, 1998) or ISO/TS 15923-2:2017 (ISO, 2017b), as appropriate,

1209 - chloride concentration (c_{Cl}) in accordance with ISO 9297:1989 (ISO, 1989), ISO 10304-4:1997 (ISO,
1210 1997), ISO 15682:2000 (ISO, 2000), ISO 10304-1:2007 (ISO, 2007), ISO 15923-1:2013 (ISO, 2013) or
1211 ISO 10304-4:2022 (ISO, 2022c), as appropriate,

1212 - copper concentration (c_{Cu}) in accordance with ISO 8288:1986 (ISO, 1986b),

1213 - iron concentration (c_{Fe}) in accordance with ISO 6332:1988 (ISO, 1988) or ISO/TS 15923-2:2017 (ISO,
1214 2017b), as appropriate,

1215 - potassium concentration (c_{K}) in accordance with ISO 9964-2:1993 (ISO, 1993b), ISO 9964-3:1993 (ISO,
1216 1993c) or ISO 14911:1998 (ISO, 1998), as appropriate,

1217 - magnesium concentration (c_{Mg}) in accordance with ISO/TS 15923-2:2017 (ISO, 2017b) or ISO 6059:1984 (ISO,
1218 1984b), as appropriate,

1219 - sodium concentration (c_{Na}) in accordance with ISO 9964-1:1993 (ISO, 1993a), ISO 9964-3:1993 (ISO,
1220 1993c) or ISO 14911:1998 (ISO, 1998), as appropriate,

1221 - nickel concentration (c_{Ni}) in accordance with ISO 8288:1986 (ISO, 1986b) and

1222 - zinc concentration (c_{Zn}) in accordance with ISO 8288:1986 (ISO, 1986b).

1223 The content of calcium (Ca), chloride (Cl⁻), copper (Cu), iron (Fe), potassium (K), magnesium (Mg), sodium (Na),
1224 nickel (Ni) and zinc (Zn) in the water on the inlet of the stack shall be subtracted from those at the stack outlet.

1225 **6.7.11 Polarisation curve measurements**

1226 The measurement of the current-voltage ($I_{\text{dc}}-U_{\text{dc}}$) characteristics or polarisation curves of WE stacks shall be
1227 determined by applying the EU harmonised polarisation curve test method for LTWEL (Malkow *et al.*, 2018b).
1228 Polarisation curve measurements are commonly performed under reference test conditions (section 6.4) at a
1229 minimum of three different set points to be specified in the test plan (section 6.6).

1230 Polarisation curve measurements under reference test conditions may act as an operation phase for *in-situ*
1231 stack regeneration to recover reversible degradation (Tsotridis and Pilenga, 2021). The test plan (section 6.6)
1232 may also foresee another type of procedure for stack regeneration to be applied prior to polarisation curve
1233 measurements.

1234 In case the cell voltage difference in galvanostatic polarisation measurements is negligible (*i. e.* less than 10
1235 mV for all data points) when starting from (near) zero current to proceed to maximum current (I_{max}) (ascending
1236 polarisation curve) compared to starting from maximum current to proceed to (near) zero current (descending
1237 polarisation curve), subsequent measurements may be conducted unidirectional with respect to changes in
1238 current while maintaining a steady stack operating temperature (Lettenmeier *et al.*, 2016).

⁽²⁹⁾ Note, the appendix to annex E.4 of the Annex XV Restriction Report on the manufacture, placing on the market and use of PFAS contains an overview on analytical methods for the analysis of PFAS in different matrices; see at <https://echa.europa.eu/restrictions-under-consideration/-/substance-rev/72301/term>.

⁽³⁰⁾ For sampling water and subsequent analysis, materials free of fluoride, PFAS and PAH shall be used.

1239 The maximum current is the current at which the voltage of any one cell in the stack is for three consecutive
 1240 samplings equal to the cut-off voltage ($U_{\text{cut-off}}$) defined prior to testing as part of the test plan (section 6.6) or
 1241 following manufacturer recommendations. As a voltage limit, the cut-off voltage is to prevent excessive stack
 1242 degradation. Thus, polarisation curve measurements are preferably conducted under galvanostatic conditions.

1243 For AWE stacks, no OCV (zero supply current) shall be used as a set point in the polarisation curve measure-
 1244 ment to prevent the flow of a reverse current in the stack leading to materials deterioration (see section 6.5).

1245 From the $I_{\text{dc}}-U_{\text{dc}}$ curve, the current-electric power ($I_{\text{dc}}-P_{\text{el}}$) curve is calculated, see equation (3.3.1b). The
 1246 energy efficiency (η_e) given by equation (6.7.16) versus the electric power density given by equation (3.3.1c)
 1247 and the electrical efficiency (η_{el}) given by equation (6.7.16) versus the electric power density are also plotted to
 1248 assess the optimum operating (working) point (**4.2.50**) of the WE stack under the test conditions.

1249 The distribution of the cell voltage is a measure of voltage homogeneity in the stack. The mean absolute
 1250 error of average cell voltage (MAE $\overline{U_{\text{cell}}}$) and standard deviation of average cell voltage (SD $\overline{U_{\text{cell}}}$) are two
 1251 complementary statistical indicators of cell voltage distribution calculated as follows

$$1252 \quad \text{MAE } \overline{U_{\text{cell}}} \text{ (mV)} = \frac{1}{N_{\text{cell}}} \sum_n |U_{\text{cell},n} \text{ (V)} - \overline{U_{\text{cell}}} \text{ (V)}| \cdot 10^3 \text{ mV/V} \quad (6.7.5a)$$

$$1253 \quad \text{SD } \overline{U_{\text{cell}}} \text{ (mV)} = \sqrt{\frac{1}{N_{\text{cell}} - 1} \sum_n (U_{\text{cell},n} \text{ (V)} - \overline{U_{\text{cell}}} \text{ (V)})^2} \cdot 10^3 \text{ mV/V} \quad (6.7.5b)$$

1254 where

$$1255 \quad \overline{U_{\text{cell}}} \text{ (V)} = \frac{1}{N_{\text{cell}}} \sum_n U_{\text{cell},n} \text{ (V)} \quad (6.7.5c)$$

1256 is the average cell voltage of all series-connected WECs in the stack; $U_{\text{cell},n}$ is the voltage of cell number n and
 1257 N_{cell} is the number of cells in the stack. A significant deviation of the average cell voltage times the number of
 1258 cells from the measured stack voltage, $U_{\text{stack}} \not\approx N_{\text{cell}} \cdot \overline{U_{\text{cell}}}$, indicates ohmic resistances in the stack materials
 1259 and contact resistances at their interfaces which are non-negligible. Such deviation also depends on the in-stack
 1260 positions of the terminals across which the individual cell voltages and the stack voltage are measured.

1261 In order to gain more insight into the performance degradation by voltage increases of the WECs in a WE
 1262 stack, a voltage breakdown analysis may optionally be performed on the measured polarisation curves for
 1263 attributing voltage increases to individual WEC components (Flick *et al.*, 2015, Gerhardt *et al.*, 2021, Dizon *et al.*,
 1264 2022). This is accomplished by additive contributions of the various overvoltages to the OCV of the WEC given
 1265 by equation (6.7.7a). Then, the voltage of the WEC is calculated as follows

$$1266 \quad U_{\text{WEC}} \text{ (V)} = U_{\text{OCV}} \text{ (V)} + U_{\text{act}} \text{ (V)} + I_{\text{dc}} \text{ (A)} \cdot R_{\text{lf}} \text{ (\Omega)} + U_{\text{conc}} \text{ (V)}; \quad (6.7.6)$$

1267 U_{act} is the activation polarisation voltage given by equation (6.7.7b), R_{lf} is the low-frequency resistance
 1268 estimated as the slope of the polarisation curve ⁽³¹⁾ and U_{conc} is the concentration polarisation voltage given
 1269 by equation (6.7.7c). Specifically, the voltage contributions are

- 1270 • Open circuit voltage or open circuit potential (U_{OCP}) which is different to the reversible voltage due to
 - 1271 – gas crossover leading to mixed electrode potentials,
 - 1272 – locally different catalyst surface concentrations and
 - 1273 – gas solubility at the water-ionomer-catalyst interface.
- 1274 • Ohmic polarisation (**4.2.49**) represented by $I_{\text{dc}} \cdot R_{\text{lf}}$ where the low-frequency resistance or ohmic resistance
 1275 of the WEC is due to
 - 1276 – the electrodes including diffusion media,
 - 1277 – the electrolyte, namely lye solution in AWE and AAEMWE and hydrated IEM in AEMWE and PEMWE,
 1278 and
 - 1279 – interfacial contact surfaces of the stack between WEC, biPs and current collectors.
- 1280 • Activation polarisation (**4.2.4**) due to the kinetics of
 - 1281 – the OER (3.1.2a), (3.1.3a) or (3.1.4a) at the anode and
 - 1282 – the HER (3.1.2b), (3.1.3b) or (3.1.4b) at the cathode.

⁽³¹⁾ The low-frequency resistance can also be determined by EIS measurements (section 6.7.12), see equation (6.7.12).

- Concentration polarisation (**4.2.20**) due to mass transfer limitations in the electrodes of the stack including hindrance caused by gas bubble formation.

In the absence of gas crossover and other non-ideal conditions, the temperature-dependent open circuit voltage is calculated as follows (Bernt, 2019)

$$U_{OCV}(T) \text{ (V)} = 1,2291 \text{ V} - 0,0008456 \text{ (V/K)} (T \text{ (K)} - 298,15 \text{ K}) + \frac{R_g \text{ (J/(mol K))} \cdot T \text{ (K)}}{z \cdot F \text{ (C/mol)}} \log \left(\frac{p_{H_2} \text{ (kPa)}}{p^0 \text{ (kPa)}} \cdot \left(\frac{p_{O_2} \text{ (kPa)}}{p^0 \text{ (kPa)}} \right)^{0,5} \right); \quad (6.7.7a)$$

p_{H_2} and p_{O_2} are the partial pressure of hydrogen and partial pressure of oxygen, respectively. The activity of liquid water (a_{H_2O}) is taken as unity. The exponent of 0,5 stems from the fact that half a mole of oxygen is generated by electrolysis from one mole of liquid water, see reaction (3.1.1). The temperature-dependent activation and concentration polarisation voltages are calculated as follows (Hernández-Gómez *et al.*, 2020)

$$U_{act}(T) \text{ (V)} = \frac{R_g \text{ (J/(mol K))} \cdot T \text{ (K)}}{z \cdot F \text{ (C/mol)}} \log \left(\left(\frac{I_{0,a}(T) \text{ (A)}}{I_a \text{ (A)}} \right)^{\alpha_a} \cdot \left(\frac{I_{0,c}(T) \text{ (A)}}{I_c \text{ (A)}} \right)^{\alpha_c} \right) \text{ and} \quad (6.7.7b)$$

$$U_{conc}(T) \text{ (V)} = \frac{R_g \text{ (J/(mol K))} \cdot T \text{ (K)}}{z \cdot F \text{ (C/mol)}} \log \left(\left(\frac{c_{O_2} \text{ (mol)}}{c_{O_2}^0 \text{ (mol)}} \right) \cdot \left(\frac{c_{H_2} \text{ (mol)}}{c_{H_2}^0 \text{ (mol)}} \right) \right); \quad (6.7.7c)$$

$I_{0,a}$, I_a , $I_{0,c}$, I_c , α_a and α_c are anodic exchange current, anodic current, cathodic exchange current, cathodic current, anodic charge transfer coefficient and cathodic charge transfer coefficient, respectively while c_{O_2} and c_{H_2} are the oxygen concentration and hydrogen concentration at the electrolyte-electrode interfaces, respectively and $c_{O_2}^0$ and $c_{H_2}^0$ are their respective equilibrium concentrations. Further information on voltage breakdown analysis is given elsewhere (Ma *et al.*, 2021, Falcão and Pinto, 2020, Gerhardt *et al.*, 2021).

6.7.12 EIS measurements

The electrical impedance (Z) of individual cells in a WE stack as a function of perturbation frequency (f)⁽³²⁾ shall be determined by applying the EU harmonised test procedure on EIS for WECs (Malkow *et al.*, 2018a) under the same test and operating conditions including the DC set point values as applied in the polarisation curve measurements (section 6.7.11). In case EIS measurements and polarisation curve measurements are conducted simultaneously, AC and DC contributions are contained in the current and voltage data. The test plan (section 6.6) shall specify the excitation type, magnitude, frequencies and the number of repetitions.

In Nyquist plots (**4.2.48**), the (negative) imaginary part of electrical impedance is plotted against the real part of electrical impedance, $(-)\Im Z$ versus $\Re Z$, Figure 6.1. The resulting graph displays one or more semi-arcs whereby the number of distinguishable semi-arcs coincides with the number of relaxation times or time constants (τ) due to polarisation processes such as charge build-up at and transfer across the WEC interfaces as well as species transport (convection, diffusion, migration, reaction, etc.) within the WEC⁽³³⁾. Often, semi-arcs overlap considerably so that not all time constants are identifiable. That is, not all polarisation processes may visually be detectable from Nyquist plots, see Figure 6.1.

In Bode plots (**4.2.14**), the modulus of electrical impedance⁽³⁴⁾ and its phase⁽³⁵⁾ are plotted against the frequency in logarithmic scale, $|Z|$, $\arg(Z)$ versus $\log f$, Figure 6.2. From a Bode plot, the values of the low-frequency resistance (R_{lf}) (see equation (6.7.12)) and the high-frequency resistance (R_{hf}) (see equation (6.7.9)) can often be read directly, which is not necessarily the case for a Nyquist plot, cf. Figure 6.2 and Figure 6.1.

⁽³²⁾ In EIS measurements, the output under potentiostatic conditions is electrical impedance, $Z=|Z|^2 Y^* =|Z| e^{i\arg(Z)}$; $|\cdot|$ denotes modulus or gain, $\arg(\cdot)$ denotes phase or argument, superscript * denotes complex conjugation and i is the imaginary unit with property, $(\pm i)^2 = -1$. Under galvanostatic conditions, the output is electrical admittance, $Y=|Y|^2 Z^* =|Y| e^{i\arg(Y)}$.

⁽³³⁾ The combination of any two distinct passive (lumped) circuit elements such as a capacitor having electrical admittance, $Y=i\omega C$, an inductor having electrical impedance, $Z=i\omega L$ and a resistor having electrical impedance, $Z=R$, arranged in parallel or, series makes up a characteristic time constant; $\omega=2\pi f$ is angular frequency. It is attributable to the dissipation of electric energy (E_{el}) by resistors accounting for the resistivity in bulk materials and resistance (R) of the various interfaces of a WEC or a WE stack due to electronic and ionic conduction as well as energy storage by capacitors accounting for capacitance (C , negative reactance) at electrically charged interfaces (*i.e.* electrolyte-electrode intersections) and inductors accounting for inductance (L , positive reactance) in conductors (*i.e.* wires, converters, etc). Non-ideal circuit elements include constant phase elements (CPEs) having electrical impedance, $Z=(i\omega)^\alpha Q_C^{-1}$ or $Z=(i\omega)^\alpha Q_L$ ($0<\alpha<1$ where α is a power exponent, Q_C is a non-ideal capacitance and Q_L is a non-ideal inductance) to account for frequency dispersion (Alexander *et al.*, 2016, Córdoba-Torres, 2017, Kartci *et al.*, 2020, Fitzek *et al.*, 2022) and distributed circuit elements (Warburg, Gerischer, etc) to account for species transport (Huang, 2018, Chowdhury and Kant, 2018, Boukamp, 2017). They too have individual (mean) time constants.

⁽³⁴⁾ Also, the real and imaginary part of electrical impedance may be displayed in Bode plots.

⁽³⁵⁾ Instead of phase or argument of electrical impedance, the tangent of loss angle of electrical impedance may be plotted against the logarithm of frequency (or angular frequency), $\tan(\Im Z/\Re Z)$ versus $\log f$ (or $\log \omega$).

1304 **Figure 6.1:** Graphical representation of the real and imaginary parts of the electrical impedance of a water
 1305 electrolysis cell in a Nyquist plot.

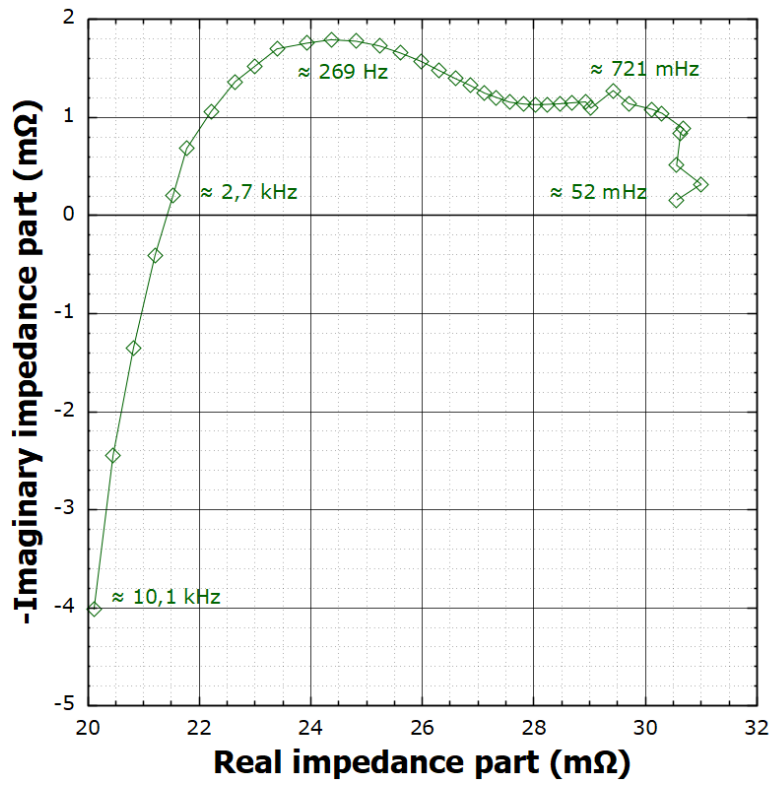

1307

1308

Source: JRC, 2023.

1316 **Figure 6.2:** Graphical representation of the electrical impedance modulus and phase of a water electrolysis
 1318 cell in a Bode plot.

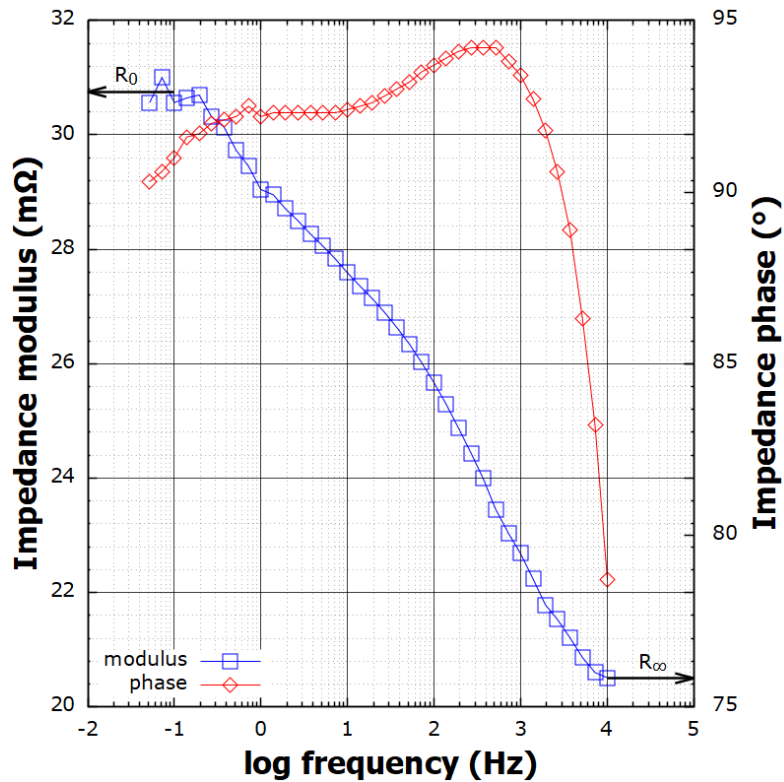

1319

1320

Source: JRC, 2023.

1325 In principle, the ohmic resistance is the infinite-frequency resistance (R_∞) that is the electrical impedance
 1326 at high frequencies ($f \rightarrow \infty$) with vanishing reactance, $\Im m Z [f \rightarrow \infty] = 0$,

$$1327 \quad \lim_{f \rightarrow \infty} \Re e Z [f] (\Omega) = R_\infty (\Omega). \quad (6.7.8)$$

1328 Practically, the ohmic resistance is the electrical impedance measured at the highest of the probed frequencies
 1329 (f_{\max}) where $\Im m Z [f \rightarrow f_{\max}] \rightarrow 0$,

$$1330 \quad \lim_{f \rightarrow f_{\max}} \Re e Z [f] (\Omega) \approx R_{\text{hf}} (\Omega) \quad (6.7.9)$$

1331 to basically represent the resistance of the electrolyte. Unfortunately, the reactance at f_{\max} is often not
 1332 negligible, $\Im m Z [f_{\max}] > 0$, see Figure 6.1. The polarisation resistance is the difference between the zero-
 1333 frequency resistance (R_0) and the infinite-frequency resistance,

$$1334 \quad R_{\text{pol}} (\Omega) = R_0 (\Omega) - R_\infty (\Omega). \quad (6.7.10)$$

1335 The zero-frequency resistance is the electrical impedance at low frequencies ($f \rightarrow 0$) with vanishing reactance,
 1336 $\Im m Z [f \rightarrow 0] = 0$,

$$1337 \quad \lim_{f \rightarrow 0} \Re e Z [f] (\Omega) = R_0 (\Omega). \quad (6.7.11)$$

1338 Practically, the zero-frequency resistance is the electrical impedance measured at the lowest of the probed
 1339 frequencies (f_{\min}) where $\Im m Z [f \rightarrow f_{\min}] \rightarrow 0$,

$$1340 \quad \lim_{f \rightarrow f_{\min}} \Re e Z [f] (\Omega) \approx R_{\text{lf}} (\Omega). \quad (6.7.12)$$

1341 Consequently, the polarisation resistance is approximated to the difference between the low-frequency resistance
 1342 and the high-frequency resistance,

$$1343 \quad R_{\text{pol}} (\Omega) \approx R_{\text{lf}} (\Omega) - R_{\text{hf}} (\Omega). \quad (6.7.13)$$

1344 The area-specific resistance is calculated as follows

$$1345 \quad R_{\text{ASR}} (\text{m}\Omega \cdot \text{cm}^2) = R_{\text{lf}} (\Omega) \cdot A_{\text{act}} (\text{cm}^2) \cdot 1000 \text{ m}\Omega/\Omega. \quad (6.7.14)$$

1346 Also, the estimated value of the slope of the polarisation curve (section 6.7.11) may be used in place of R_{lf} to
 1347 calculate R_{ASR} according to equation (6.7.14).

1348 Guidance on EIS measurements (Siracusano *et al.*, 2018, Szekeres *et al.*, 2021) is provided by clause 10.7.2.2
 1349 of IEC 62282-7-2:2014 (IEC, 2014b) and clause 6.3.10 of IEC 62282-8-101:2020 (IEC, 2020c) while guidance
 1350 on post processing of EIS data is provided by clause 7.6.3 of IEC 62282-8-101:2020 (IEC, 2020c). Note, useful
 1351 software tools to perform such data post-processing are listed in term 403 on p. 66 (online version) of the
 1352 recently published electrolysis terminology document (Malkow *et al.*, 2021).

1353 Further, advanced EIS data analysis includes the method of distribution of uncorrelated relaxation times
 1354 (DRT) (Boukamp, 2020) for detecting better resolved time constants (relaxation times) without explicit assump-
 1355 tions except for the applicability of the principle of superposition (**4.2.64**). Primarily, DRT analysis provides for the
 1356 total number and the values of relaxation times being the time constants of relaxation phenomena occurring in
 1357 WECs due to heat and species transport (conduction, convection, diffusion, migration, reaction, etc). Significant
 1358 changes in these parameters upon prolonged in-stack exposure of a WEC under normal operating conditions
 1359 or stressing operating conditions may occur due to degradation. Further, the number of time constants in the
 1360 equivalent electric circuit (EEC) model should necessarily match the number of relaxation times unambiguously
 1361 identified by DRT analysis. Also, the polarisation resistance is the area under the graph of the DRT (Malkow,
 1362 2019). Depending on the EIS data, the value of the DRT function can be real or complex (Malkow, 2021) ⁽³⁶⁾.

1363 Advantageously, the determined values of the time constants and the polarisation resistance may serve
 1364 as initial start values for subsequent complex non-linear least squares (CNLS) fitting of the measured EIS
 1365 data to a suitable EEC model simulating the observed WEC electrical impedances (Boukamp, 2004, Macdonald
 1366 and Potter, 1987, Boukamp, 1986). This type of data post-processing, also known as parameter identification,
 1367 may eventually identify WEC parameters as values of sought microscopic quantities (diffusion coefficients,
 1368 permeabilities, reaction rates, etc). A simplified EEC model of an electrolyser connected to a DC source is
 1369 presented in Figure 6.3 (Chen *et al.*, 2022).

⁽³⁶⁾ Unfortunately, software codes to determine complex-valued DRT are not available to-date. Also, a theory of DRT functions with correlated relaxation times representative of interdependent (hierarchical, interacting, coupled or cooperative), spatially distributed or delayed polarisation processes (resistive-capacitive or resistive-inductive) prevailing in electrochemical cells (**4.2.32**) including WECs is yet missing.

1370 **Figure 6.3:** Simplified EEC model of an electrolyser connected to a DC source; $C_{dl,a}$, $C_{dl,c}$, $R_{ct,a}$ and $R_{ct,c}$ are
 1371 the temperature-dependent anodic double layer capacitance, cathodic double layer capacitance,
 1372 anodic charge transfer resistance and cathodic charge transfer resistance, respectively and R_{Ω} is
 1373 the temperature-dependent ohmic resistance.

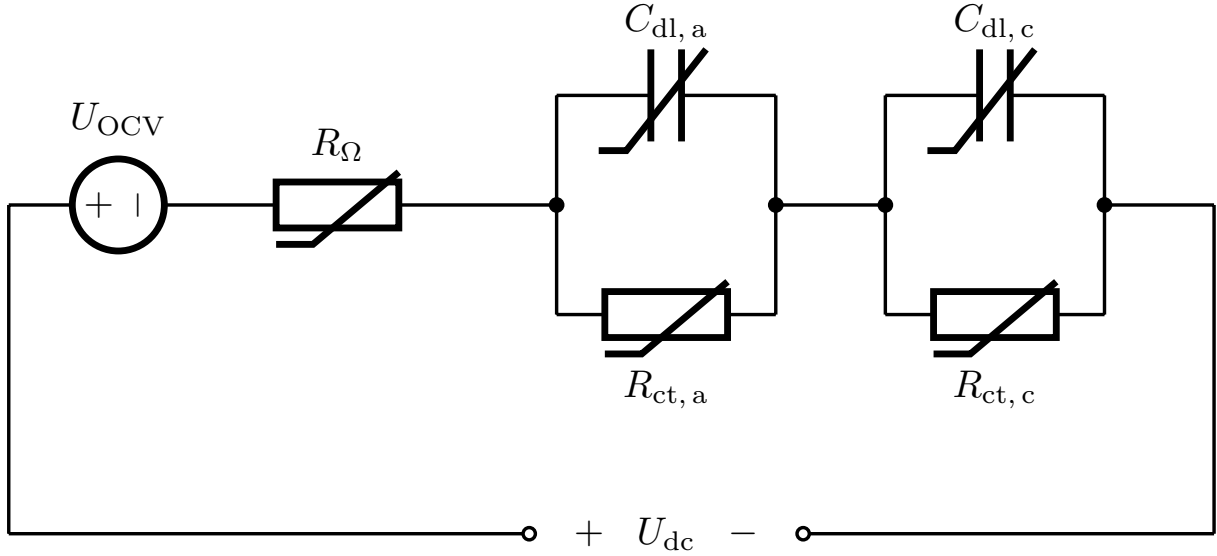

1375
 1376
 1377

Source: JRC, 2023.

1378 The anodic double layer capacitance, cathodic double layer capacitance, anodic charge transfer resistance and
 1379 cathodic charge transfer resistance are calculated as follows

$$1380 \quad C_{dl,a}(T) \text{ (mF)} = \frac{\varepsilon(T) \text{ (F/m)} \cdot A_{act} \text{ (cm}^2\text{)}}{d_{dl} \text{ (nm)}} \cdot 10^5 \text{ cm}^2/\text{nm/m} \cdot 10^{-3} \text{ mF/F}, \quad (6.7.15a)$$

$$1381 \quad C_{dl,c}(T) \text{ (mF)} = \frac{\varepsilon(T) \text{ (F/m)} \cdot A_{act} \text{ (cm}^2\text{)}}{d_{dl} \text{ (nm)}} \cdot 10^5 \text{ cm}^2/\text{nm/m} \cdot 10^{-3} \text{ mF/F}, \quad (6.7.15b)$$

$$1382 \quad R_{ct,a}(T) \text{ (}\Omega\text{)} = \frac{R_g \text{ (J/(mol K))} \cdot T \text{ (K)}}{z \cdot F \text{ (C/mol)} \cdot I_{0,a}(T) \text{ (A)}} \text{ and} \quad (6.7.15c)$$

$$1383 \quad R_{ct,c}(T) \text{ (}\Omega\text{)} = \frac{R_g \text{ (J/(mol K))} \cdot T \text{ (K)}}{z \cdot F \text{ (C/mol)} \cdot I_{0,c}(T) \text{ (A)}}; \quad (6.7.15d)$$

1384 ε is the absolute permittivity of the double layer having length d_{dl} .

1385 6.7.13 Efficiency determination

1386 The energy efficiency based on HHV under SATP conditions of hydrogen ($\eta_{HHV,e}^0$), the energy efficiency based on
 1387 LHV under SATP conditions of hydrogen ($\eta_{LHV,e}^0$), the electrical efficiency based on HHV under SATP conditions of
 1388 hydrogen ($\eta_{HHV,el}^0$) and the electrical efficiency based on LHV under SATP conditions of hydrogen ($\eta_{LHV,el}^0$) of a WE
 1389 stack shall be determined applying the recently published energy performance testing procedure (Malkow and
 1390 Pilenga, 2023a) under the same test and operating conditions as applied in the polarisation curve measurements.
 1391 These four efficiencies are defined as

$$1392 \quad \eta_{HHV,e}^0 \text{ (%) } = \frac{q_{n,H_2} \text{ (mol/h)} \cdot HHV_{H_2} \text{ (kWh/mol)}}{P_{el,dc} \text{ (kW)} + P_{th} \text{ (kW)} + P_{compr} \text{ (kW)}} \cdot 100 \text{ %}, \quad (6.7.16a)$$

$$1394 \quad \eta_{LHV,e}^0 \text{ (%) } = \frac{q_{n,H_2} \text{ (mol/h)} \cdot LHV_{H_2} \text{ (kWh/mol)}}{P_{el,dc} \text{ (kW)} + P_{th} \text{ (kW)} + P_{compr} \text{ (kW)}} \cdot 100 \text{ %}, \quad (6.7.16b)$$

$$1396 \quad \eta_{HHV,el}^0 \text{ (%) } = \frac{q_{n,H_2} \text{ (mol/h)} \cdot HHV_{H_2} \text{ (kWh/mol)}}{P_{el,dc} \text{ (kW)}} \cdot 100 \text{ %} \text{ and} \quad (6.7.16c)$$

$$1398 \quad \eta_{LHV,el}^0 \text{ (%) } = \frac{q_{n,H_2} \text{ (mol/h)} \cdot LHV_{H_2} \text{ (kWh/mol)}}{P_{el,dc} \text{ (kW)}} \cdot 100 \text{ %}; \quad (6.7.16d)$$

1399 $HHV_{H_2} = 79,4 \text{ kWh/mol}$ and $LHV_{H_2} = 67,2 \text{ kWh/mol}$ are respectively the higher heating value and the lower
 1400 heating value of hydrogen under SATP conditions (Tsotridis and Pilenga, 2018).

6.8 Operation profiles

6.8.1 General

Operation profiles, whether profiles of the input electric power, input direct current or input DC voltage versus time (t), are intended to simulate, under given test conditions (section 6.3), stack operation for use in the application concerned. Apart from simulated operation profiles (Alia *et al.*, 2019, Allidières *et al.*, 2019, Aßmann *et al.*, 2020, Tsotridis and Pilenga, 2021, Malkow and Pilenga, 2023b, Reissner *et al.*, 2020), this includes real-world operation profiles (duty cycles) derived from RES-based power profiles typical for the intermittent supply of electricity to a WE system by various RES types, namely PV power (4.2.59) and wind power (4.2.80).

Herein, we use open data of the Belgian electricity grid with a 15 minutes time resolution (Elia Transmission Belgium SA, 2023) by normalising the measured electric power (P_{el}) by the monitored peak electric power to derive operation profiles for PV electric power (Figure 6.4 and Figure 6.5) and wind turbine (WT) electric power (Figure 6.6 and Figure 6.7).

For testing, the derived profiles are expressed in terms of input electric power or translated into input current using a typical value of rated voltage or translated into input voltage using the rated current. The time interval of a profile (duty cycle) is usually a fixed period comprising the time required to carry out a given number of consecutive profiles of the same type or a sequence of profiles of different types. Thus, individual profiles (duty cycles) may constitute building blocks of a test sequence specified in the test plan (section 6.6).

6.8.2 Graphical representation

Figure 6.4 shows graphical representations of daily operation profiles (normalised set point versus duration) derived from PV electric power for two randomly selected summer and winter weeks in Brussels. Figure 6.5 shows the graphical representation of an operation profile for one randomly selected year of PV electric power.

Figure 6.6 shows the graphical representation of daily operation profiles derived from onshore WT electric power in Flanders and offshore WT electric power in Belgium for the same two summer and winter weeks as selected in Figure 6.4. These profiles may likewise be used as building blocks for a sequence of operation profiles to test a WE stack supplied by WT electric power. Figure 6.7 shows the graphical representation of an operation profile for one year of onshore and offshore WT electric power, which includes the four weekly operation profiles presented in Figure 6.6.

Figure 6.4: Daily operation profiles derived from weekly PV electric power for WE stack testing. The four weeks are random selections. They are part of the year selected in Figure 6.5.

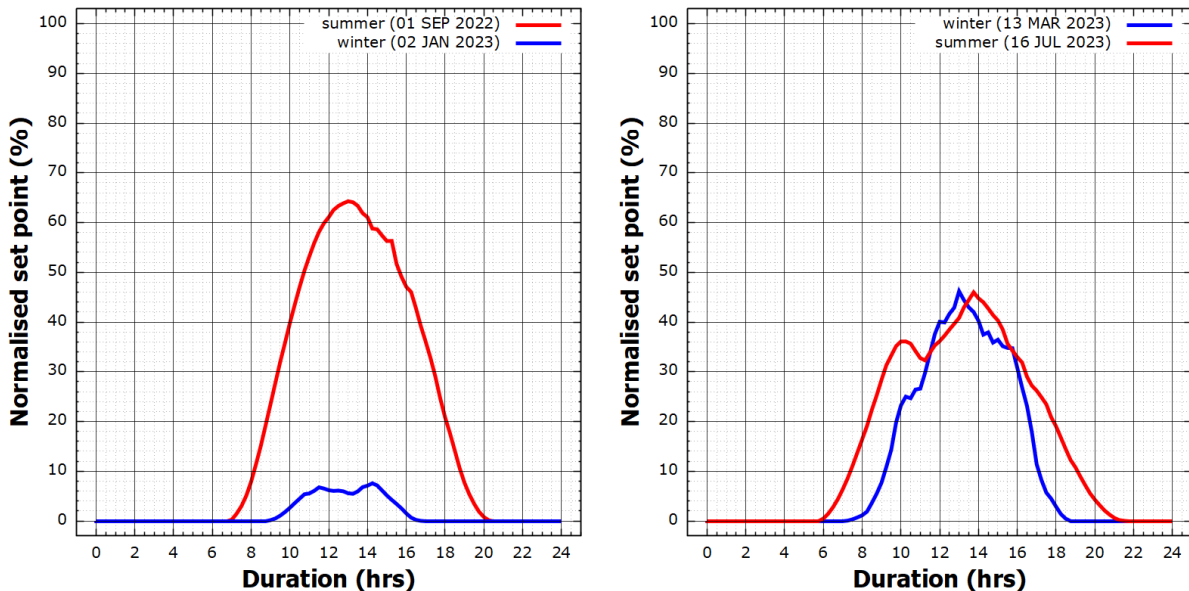

Continue to next page

Figure 6.4 – continued from previous page

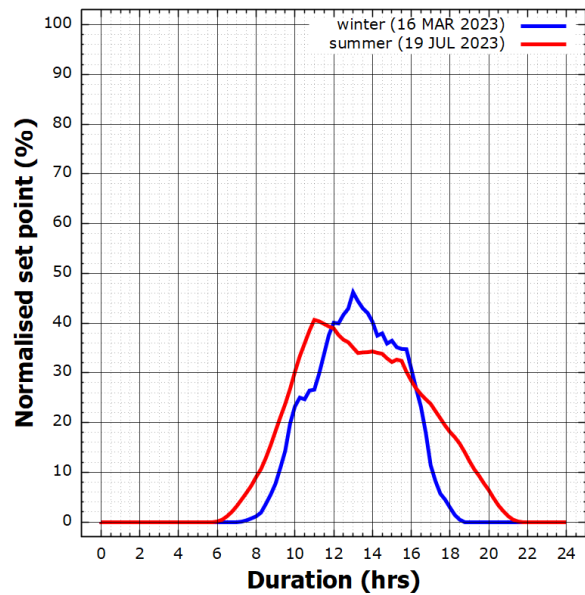
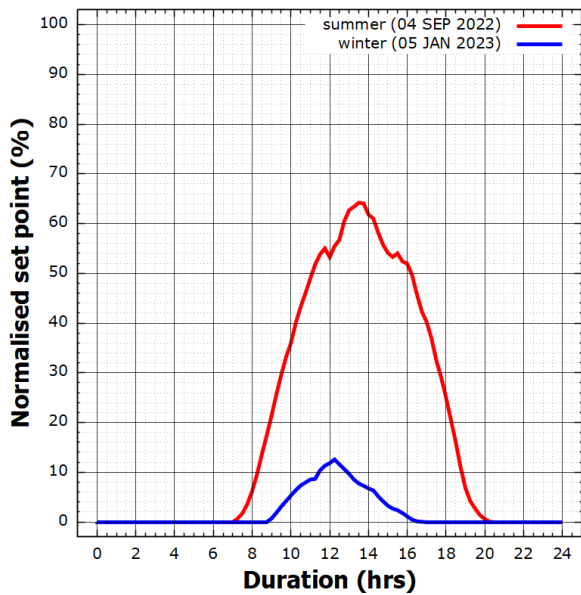
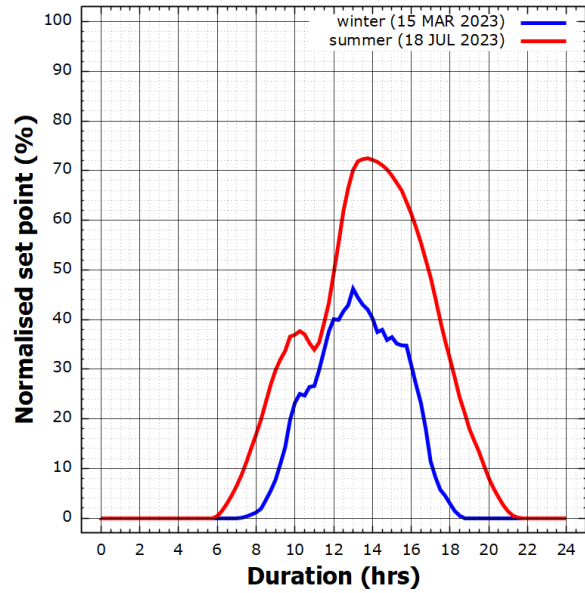
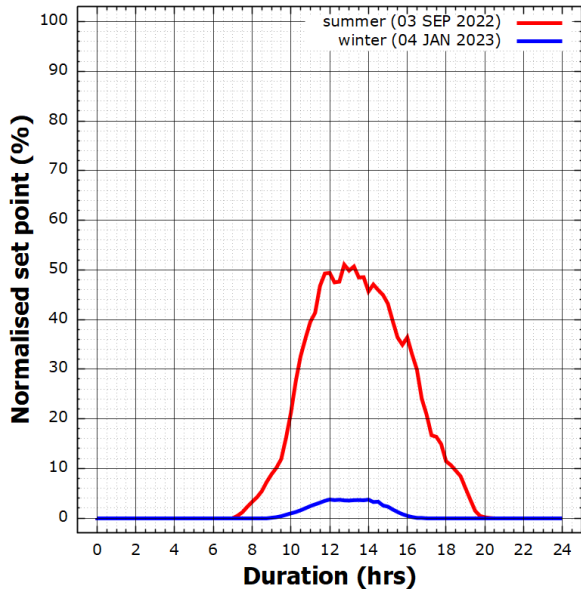
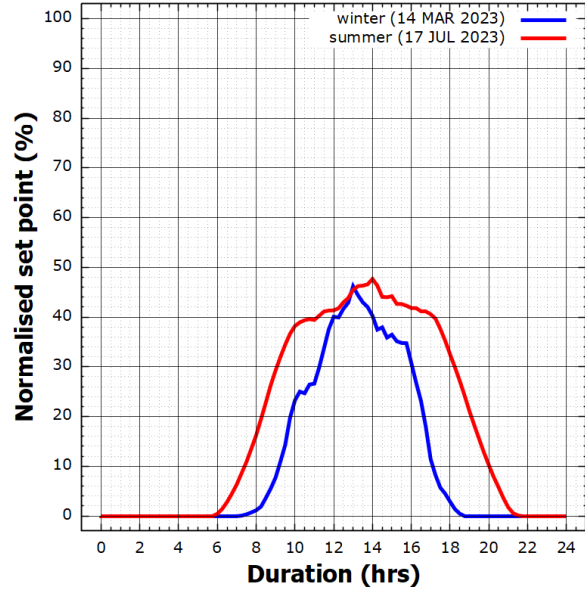
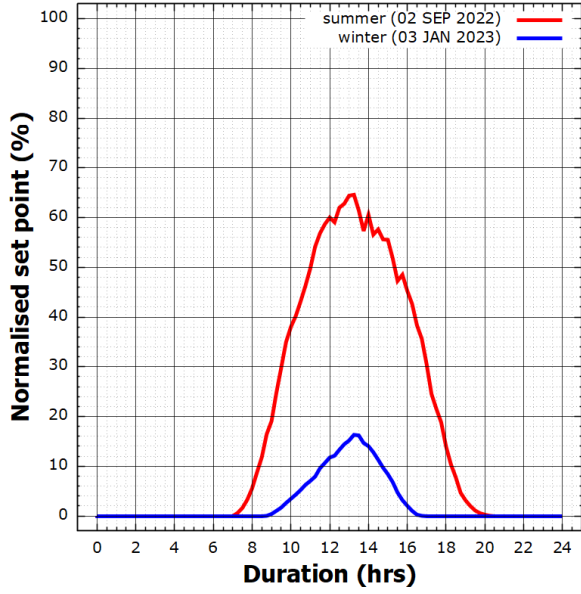

Continue to next page

Figure 6.4 – continued from previous page

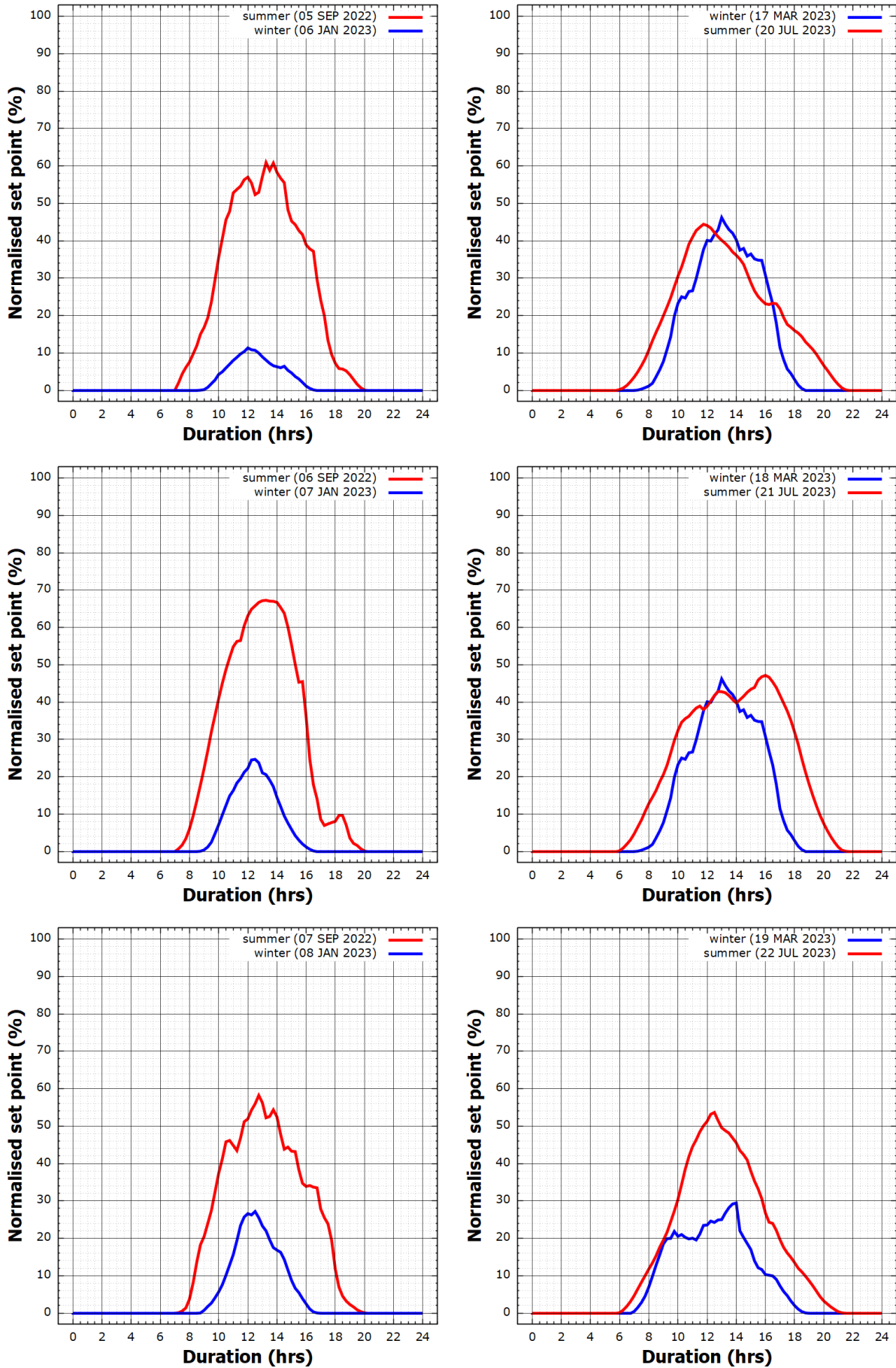

1429
1430

Figure 6.5: Operation profile derived from one year PV electric power for long-term WE stack testing. The year with its start and end dates is a random selection.

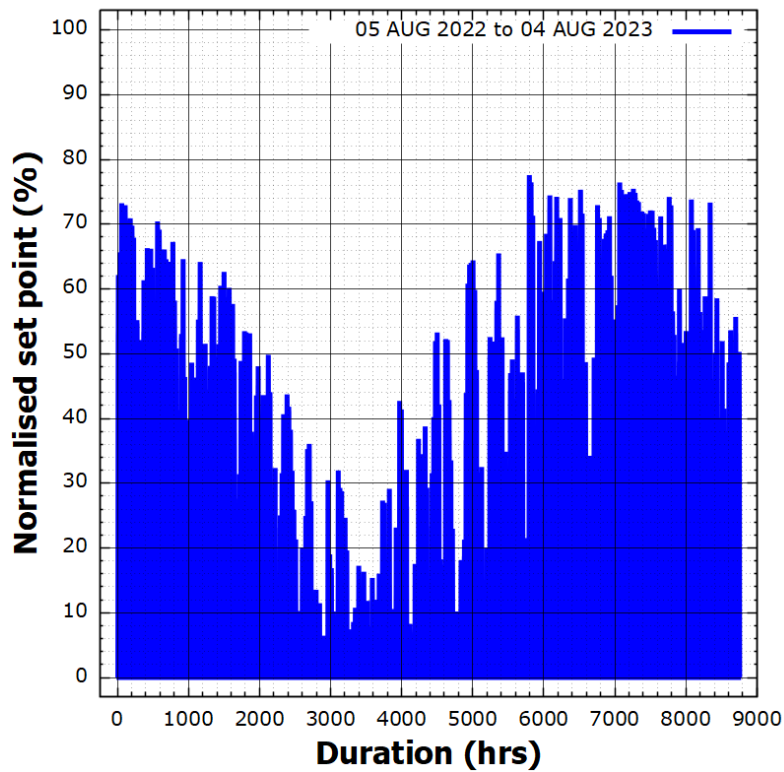

1432
1433

Source: JRC, 2023 (Malkow, 2023a).

Figure 6.6: Daily operation profiles derived from weekly onshore and offshore WT electric power for WE stack testing. The same four summer and winter weeks as in Figure 6.4 were used.

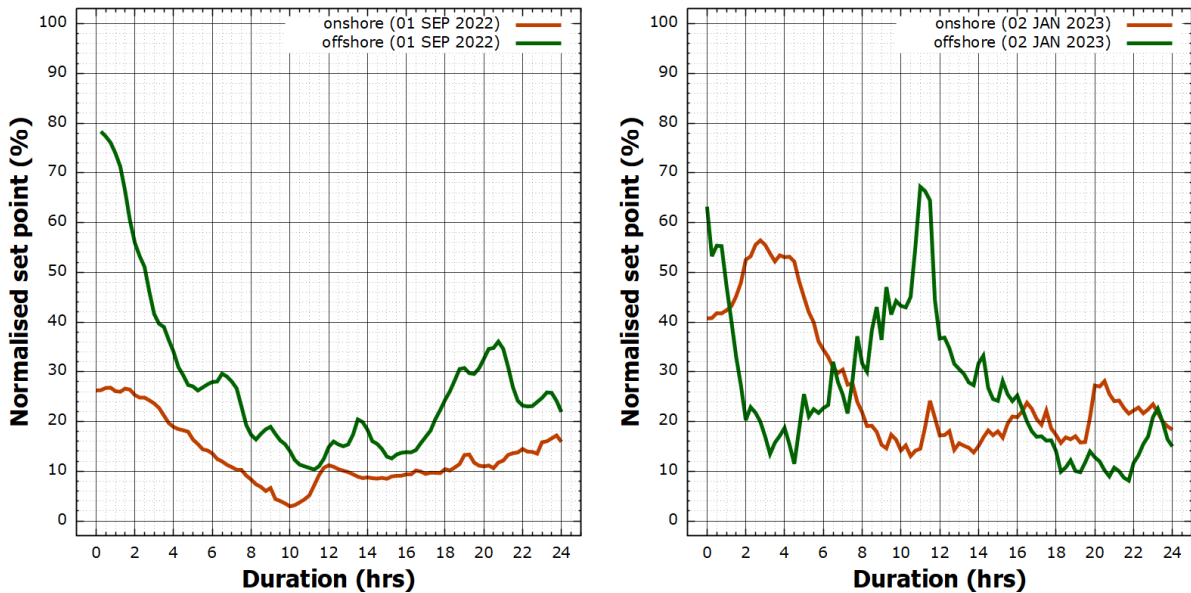

Continue to next page

Figure 6.6 – continued from previous page

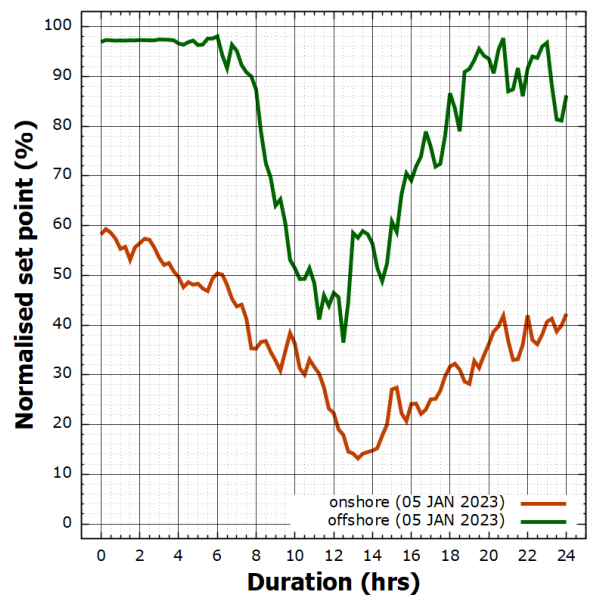
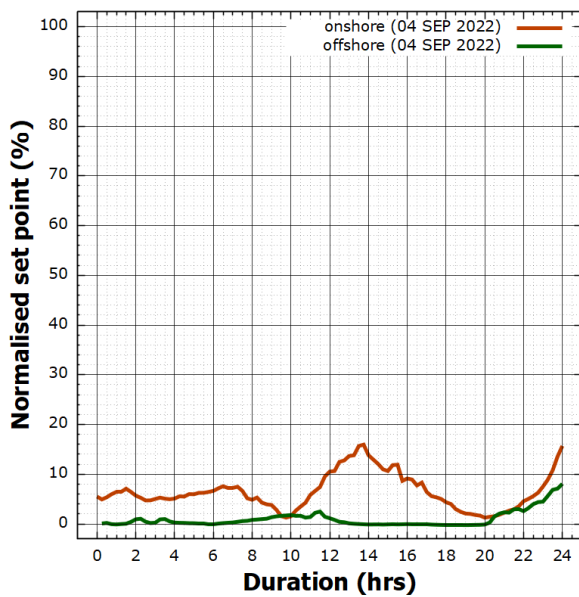
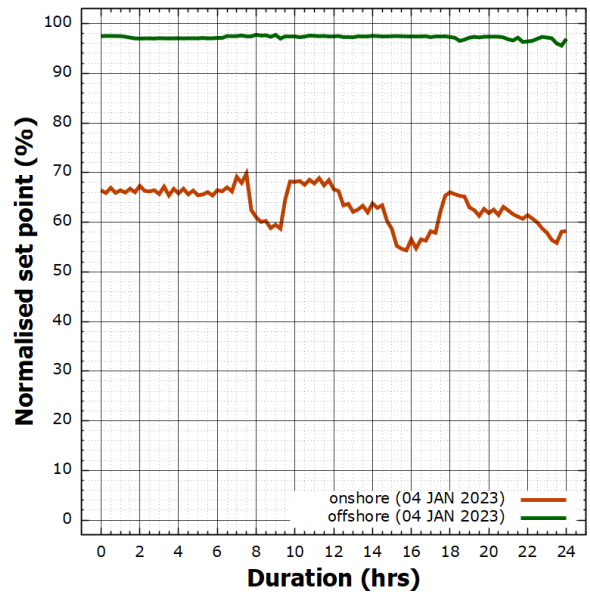
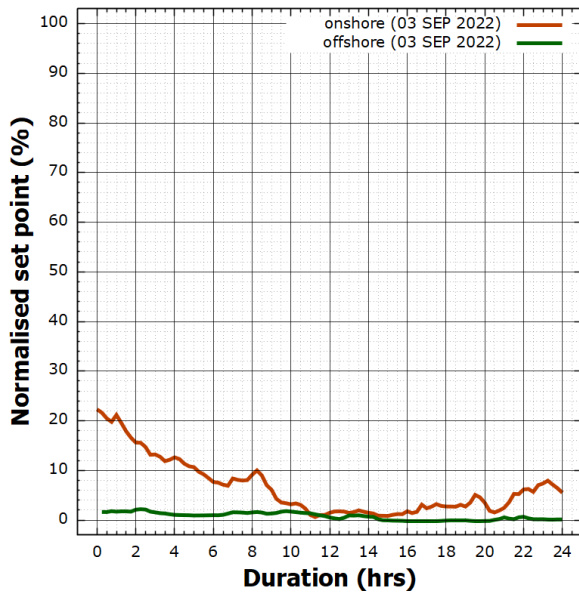
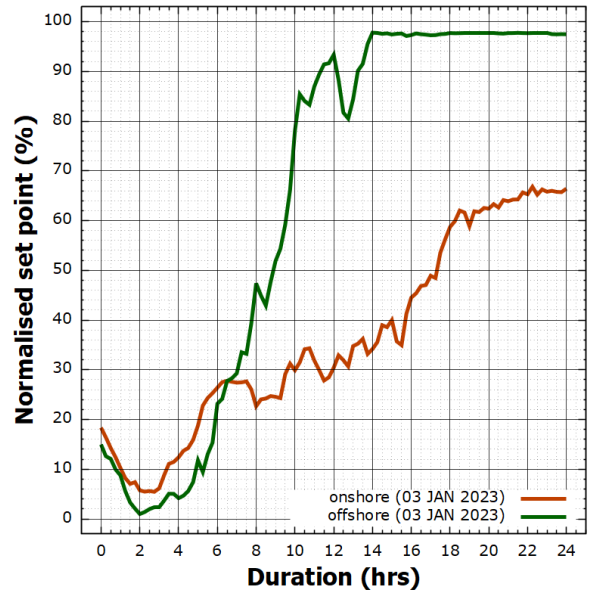
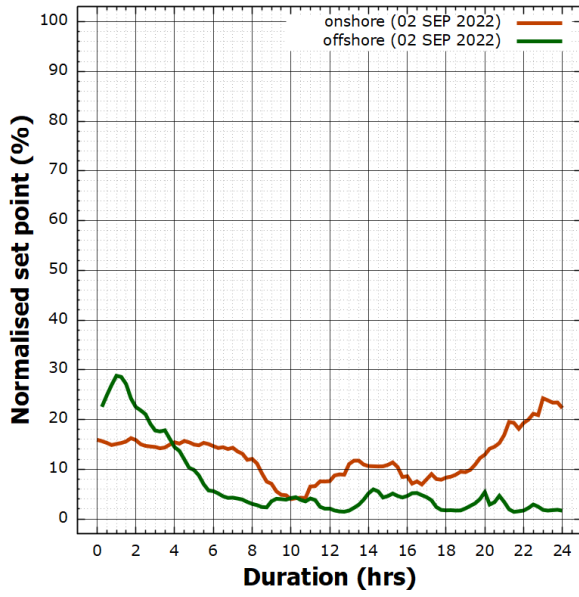

Continue to next page

Figure 6.6 – continued from previous page

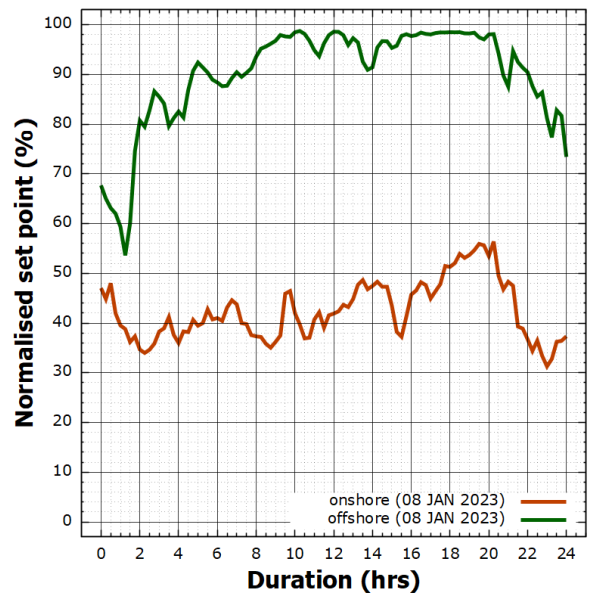
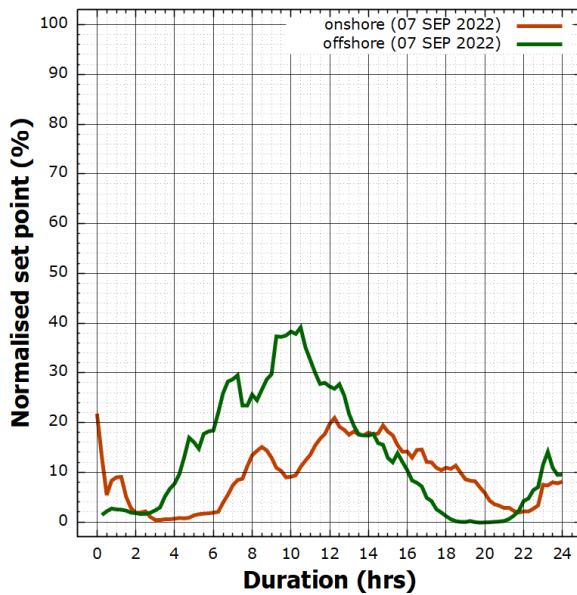
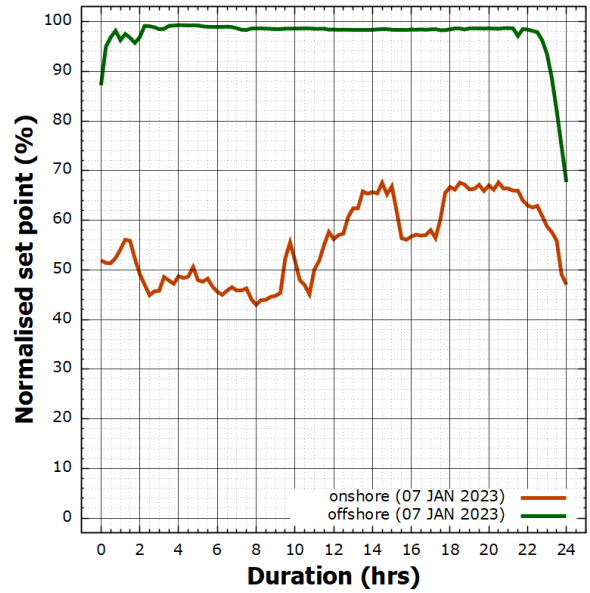
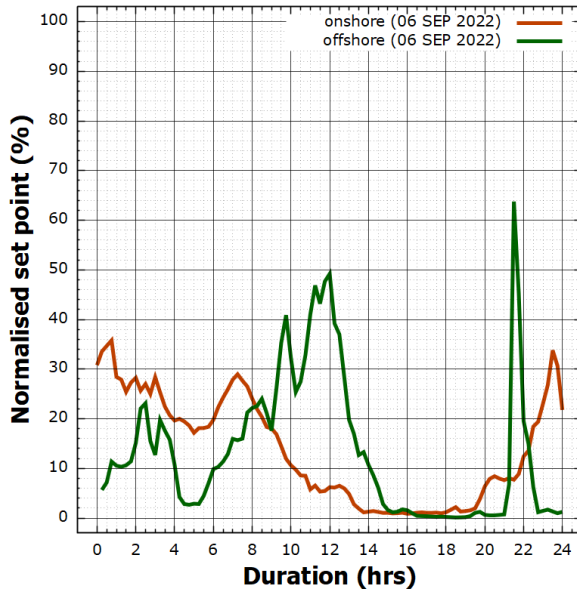
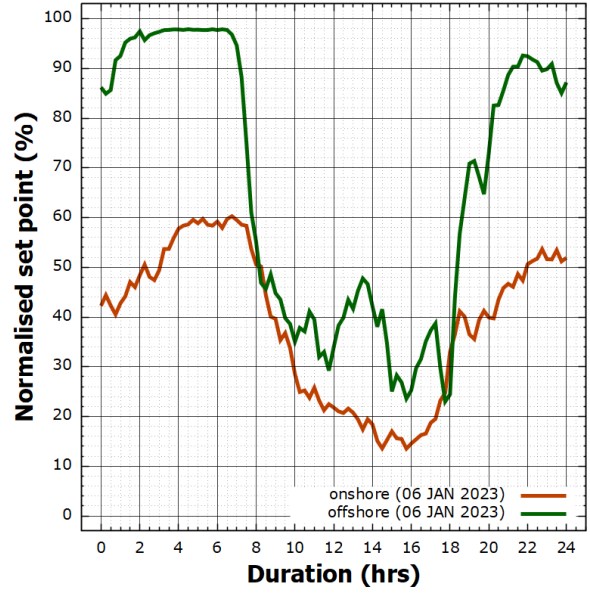
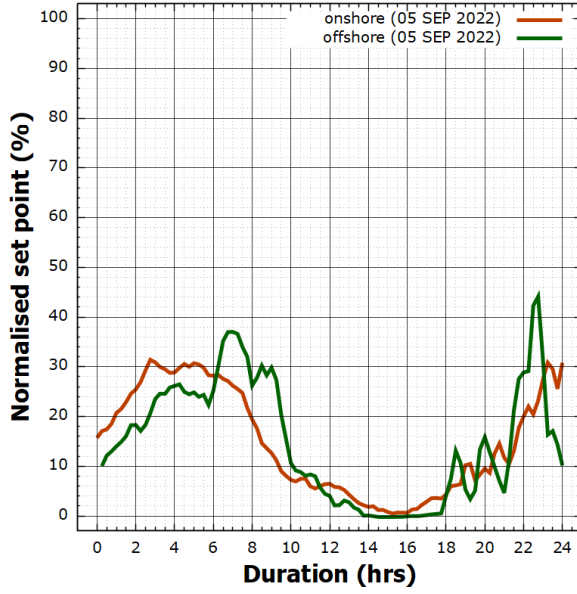

Continue to next page

Figure 6.6 – continued from previous page

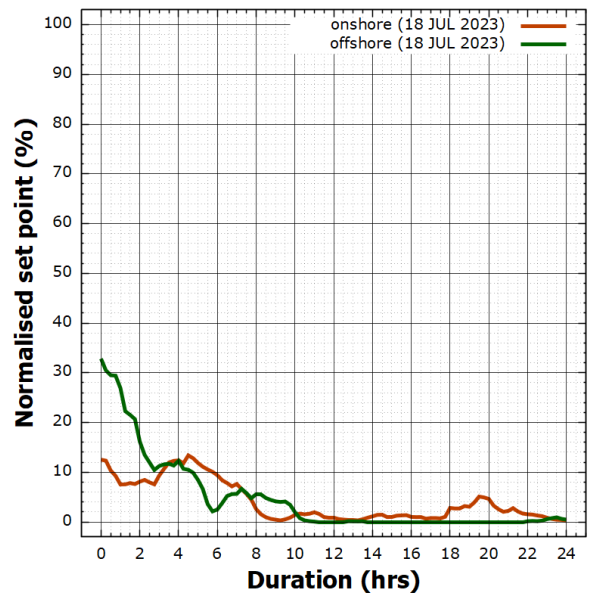
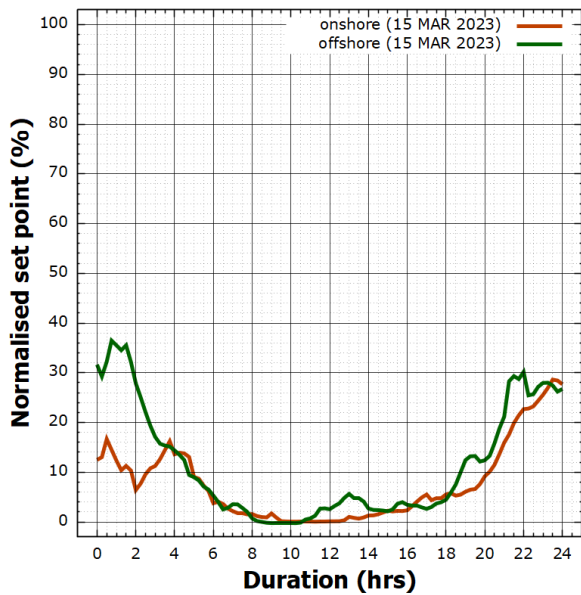
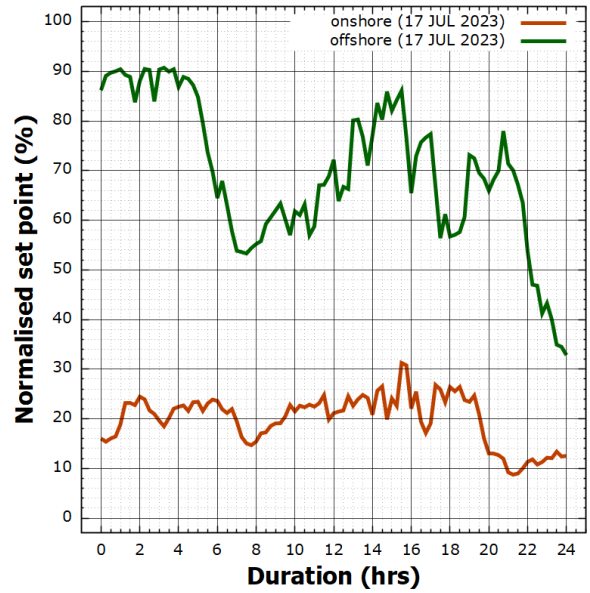
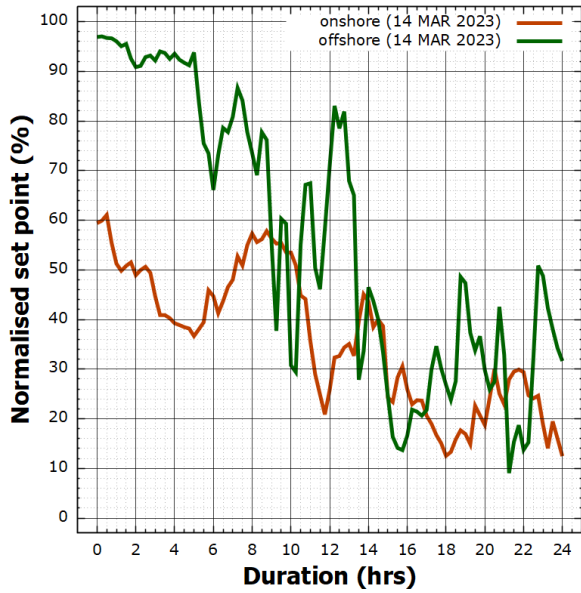
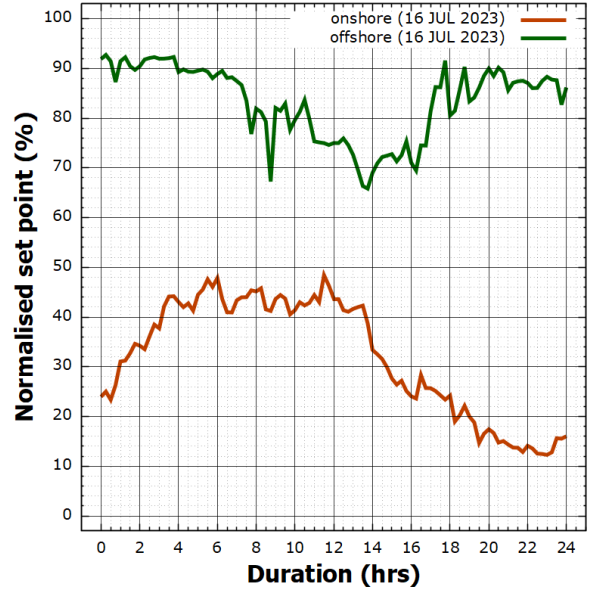
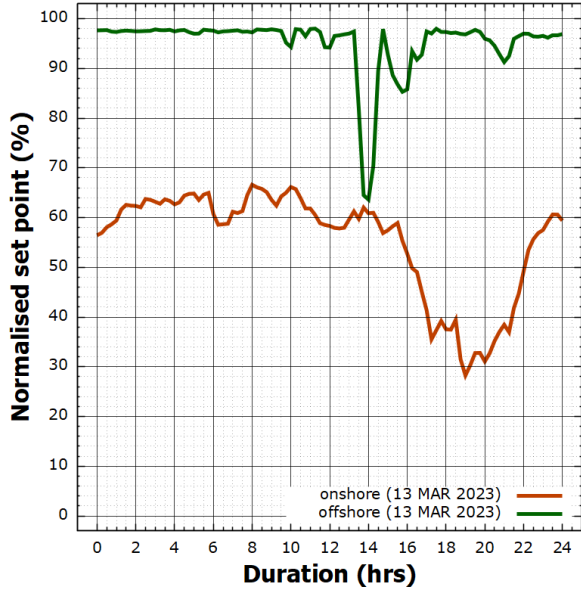

Continue to next page

Figure 6.6 – continued from previous page

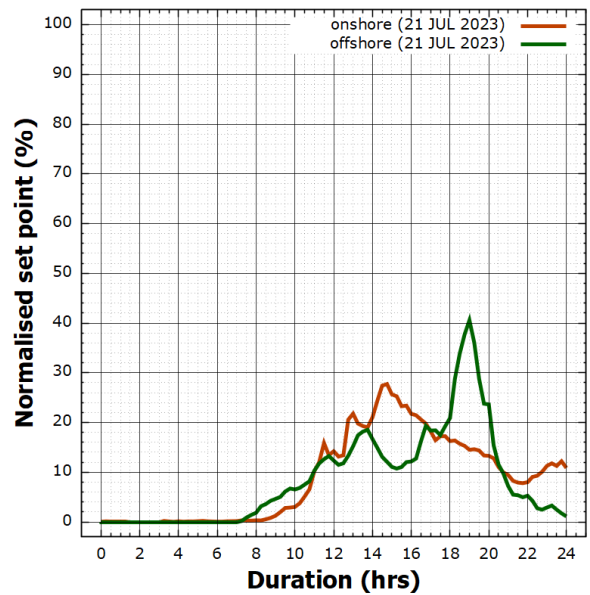
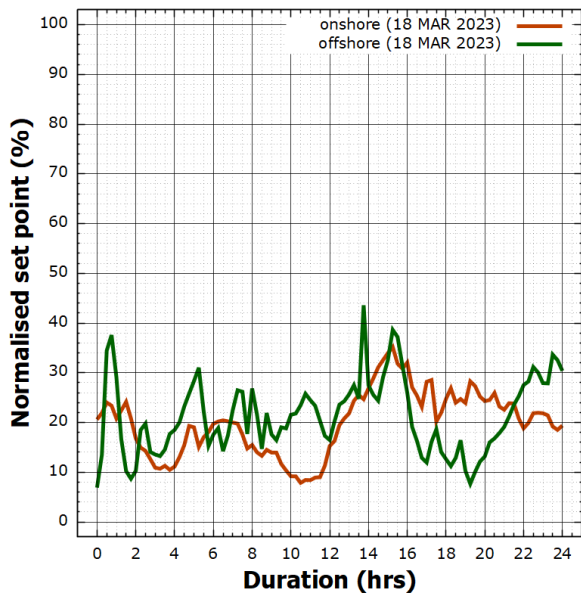
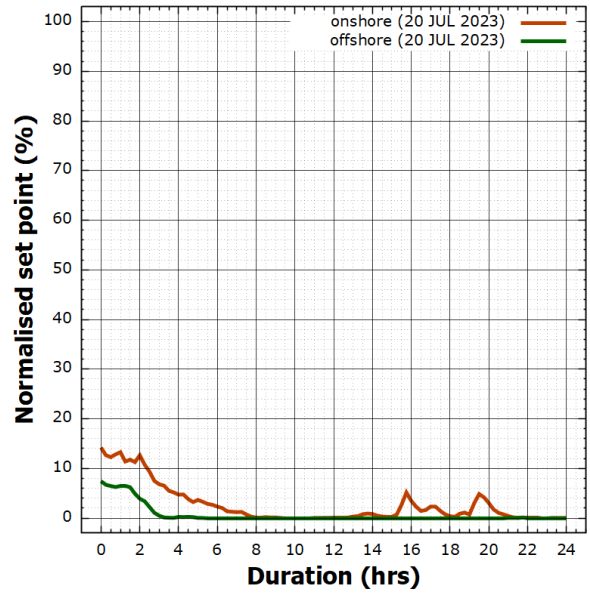
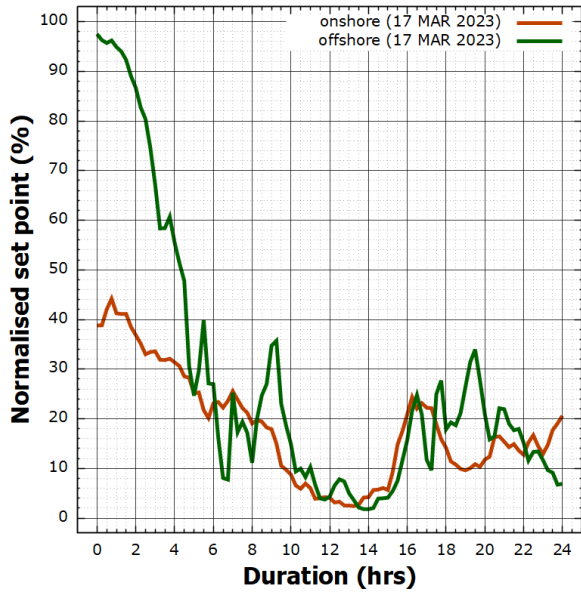
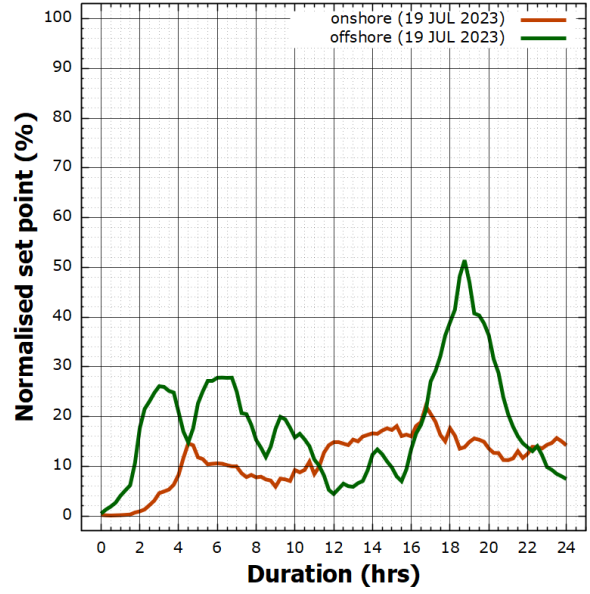
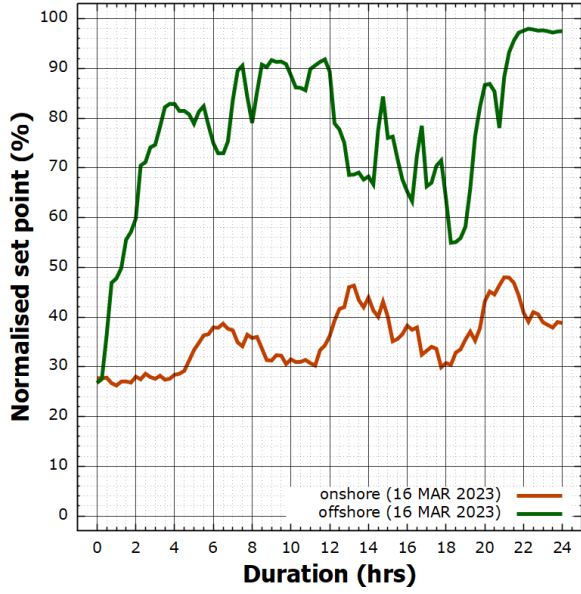

Continue to next page

Figure 6.6 – continued from previous page

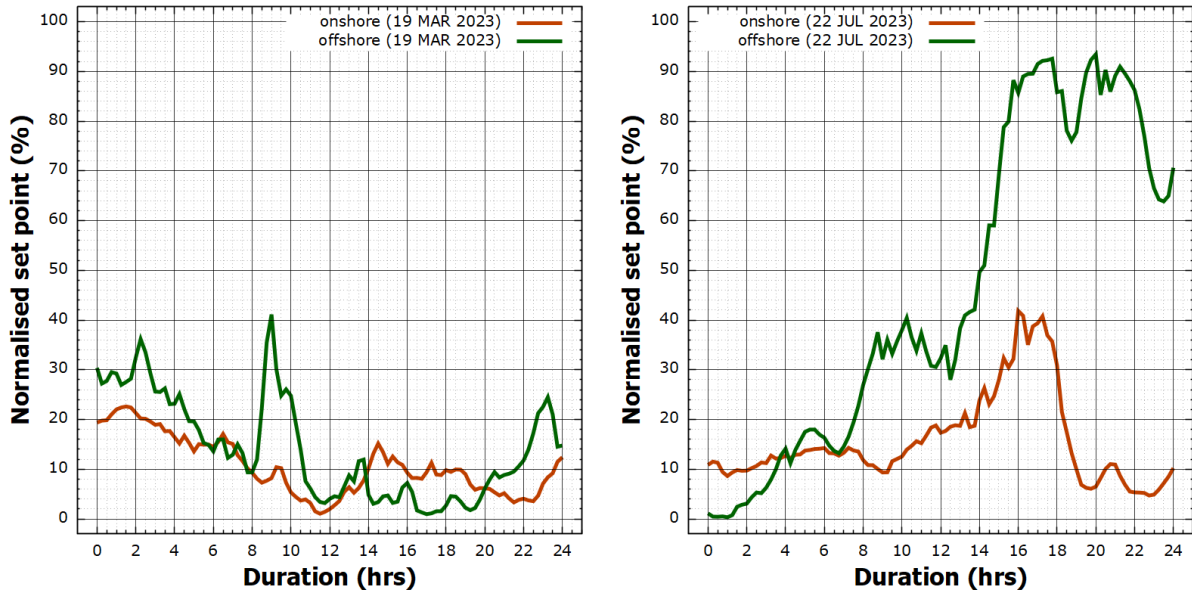

1434

Source: JRC, 2023 (Malkow, 2023b).

Figure 6.7: Operation profile derived from one year onshore and offshore WT electric power for long-term WE stack testing. The start and end dates are the same as in Figure 6.5.

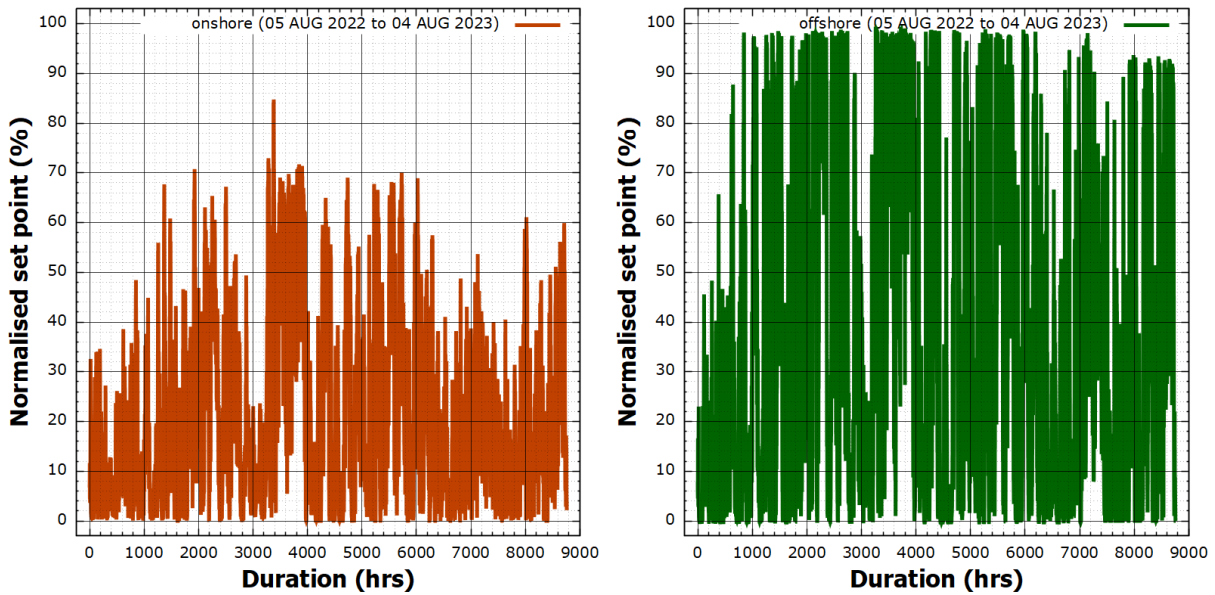

Source: JRC, 2023 (Malkow, 2023b).

1435 In Figure 6.4 to Figure 6.7, the normalised set point is either the ratio of the specified input

- 1436 • electric power to its nominal (rated) value ($P_{el, nom}$) specified by the manufacturer, namely

1437
$$\text{Normalised electric power set point (\%)} = \frac{P_{el, in} \text{ (kW)}}{P_{el, nom} \text{ (kW)}} \cdot 100 \%,$$

- 1438 • current to its nominal (rated) value (I_{nom}) specified by the manufacturer, namely

1439
$$\text{Normalised current set point (\%)} = \frac{I_{in} \text{ (A)}}{I_{nom} \text{ (A)}} \cdot 100 \%$$
 or

- 1440 • voltage to its nominal (rated) value (U_{nom}) specified by the manufacturer, namely

1441
$$\text{Normalised voltage set point (\%)} = \frac{U_{in} \text{ (kV)}}{U_{nom} \text{ (kV)}} \cdot 100 \%.$$

1442 The operation profiles displayed in Figure 6.4 to Figure 6.5 should only be applied where the specification of
1443 the WE stack by the manufacturer allow operation at zero input electric power or zero input current. If not, the
1444 profiles should be adapted accordingly, for example, by adding a positive offset.

1445 In an AST campaign, the daily operation profiles displayed in Figure 6.4 and Figure 6.6 may be combined and
1446 used together with appropriate compression factors as building blocks for one or other sequence of operation
1447 profiles forming simulated duty cycles to test WE stacks supplied by fluctuating RES-derived electricity stemming
1448 from variable PV electric power and/or WT electric power.

1449 Similarly, the yearly operation profiles displayed in Figure 6.5 and Figure 6.7 may also be combined using
1450 appropriate compression factors for accelerated stress testing of WE stacks. Without any compressed duration,
1451 these profiles could also serve in accelerated lifetime testing of WE stacks.

1452 **6.9 Durability tests**

1453 **6.9.1 General**

1454 Durability tests (4.2.28) on WE stacks evaluate the ability of the stack to maintain its performance character-
1455 istics under specified test conditions for a given time interval ⁽³⁷⁾ either at constant "steady-state" operation
1456 (section 6.9.2) or variable operation (section 6.9.3). Combinations of both modes of operation typical for a stack
1457 in a given application are possible. Preferably, the original duration of each interval comprises one thousand or
1458 more hours of stack operation.

1459 In addition to performance tests at BoT and EoT, performance tests (section 6.7) may, as an option, be
1460 conducted intermittently at intervals ($k=1,2,\dots$) to determine one or more KPIs. Importantly, BoT should not be
1461 BoL for a stack. The stack should operate for a sufficient long period recommended by the manufacturer with a
1462 minimum of 1000 hours of operation in order to overcome the phase of possible initial high degradation, which
1463 is common after operating the stack for the first time.

1464 The inability of a stack to maintain its performance characteristics during durability testing in accordance
1465 with a specified stop criterion is considered a stack failure.

1466 **6.9.2 Constant stack operation**

1467 Durability testing of a WE stack under constant current or constant voltage should be conducted in accordance
1468 with clause 7.3 of IEC 62282-8-102:2019 (IEC, 2019b).

1469 Constant stack operation is performed by two similar methods namely

1470 **Method A)** Constant current method by setting the current to its specified value according to the test plan
1471 (section 6.6) and maintain it until the stack voltage is stabilised within ± 5 mV for every cell in the stack upon
1472 which the test is carried out for its specified duration (section 6.6) while recording the current, stack voltage
1473 and stack operating temperature as minimum.

1474 **Method B)** Constant voltage method by setting the stack voltage to its specified value according to the test
1475 plan (section 6.6) and maintain it until the current has stabilised within ± 2 % upon which the test is carried
1476 out for its specified duration (section 6.6) while recording the current, stack voltage and stack operating
1477 temperature as minimum.

1478 **6.9.3 Variable stack operation**

1479 Durability testing of a WE stack under variable power, current or voltage using operation profiles (section 6.8)
1480 should be conducted in accordance with clause 7.4 of IEC 62282-8-102:2019 (IEC, 2019b).

1481 The test is carried out by setting the specified test conditions (section 6.3) including stressing operating
1482 conditions (section 6.5) to the stack and maintain these conditions either for a specified duration or until a
1483 specified voltage is obtained according to the test plan (section 6.6) while applying the operation profiles to the
1484 stack. As minimum, the current, stack voltage and stack operating temperature shall be recorded throughout
1485 the test.

1486 **6.10 Determination of KPIs**

1487 For a given stack current density (J_{stack}), stack operating temperature (T_{stack}) and pressure of hydrogen (p_{H_2}),
1488 the durability of a WE stack at an elapsed time interval t_k is assessed from the difference (deviation) of the

⁽³⁷⁾ The interval may comprise a specified duration or the time required to complete a given number or sequence of operation profiles (duty cycles).

1489 stack voltage at that instant, $U(t_k)$ and the stack voltage at t_0 , $U(t_0)$, by calculating the total rate of change of
 1490 voltage ($\Delta_{\text{tot}}^k U$), whether positive (degradation) or negative (improvement), as follows ⁽³⁸⁾

$$1491 \quad \Delta_{\text{tot}}^k U \text{ (}\mu\text{V/h)} = \frac{U(t_k) \text{ (kV)} - U(t_0) \text{ (kV)}}{t_k \text{ (h)} - t_0 \text{ (h)}} \cdot f_{\text{compr}} \cdot 10^9 \mu\text{V/kV}; \quad (6.10.1)$$

1492 t_k is the time elapsed from BoT at t_0 until the time at the end of interval k whether for constant stack operation
 1493 (section 6.9.2) or variable stack operation (section 6.9.3). At both instants, t_0 and t_k , the stack voltages shall be
 1494 determined from polarisation curve measurements (section 6.7.11) conducted under galvanostatic conditions.
 1495 The stack current density is usually the one occurring at the thermal-neutral voltage of the stack when operated
 1496 under given conditions of temperature and pressure of hydrogen at BoT. But it may, according to the test plan,
 1497 be the stack current density occurring at a stack voltage different from the thermal-neutral voltage ⁽³⁹⁾.

1498 The relative rate of change of voltage ($\Delta_{\text{rel}}^k U$) corresponding to a minimum of one thousand hours of
 1499 stack operation times the compression factor ⁽⁴⁰⁾, whether positive (degradation) or negative (improvement), is
 1500 calculated as follows (McPhail *et al.*, 2022)

$$1501 \quad \Delta_{\text{rel}}^k U \text{ (%) } = \left(\frac{U(t_k) \text{ (kV)}}{U(t_0) \text{ (kV)}} - 1 \right) \cdot \frac{1000 \text{ (h)} \cdot f_{\text{compr}}}{t_k \text{ (h)}} \cdot 100 \text{ \%}. \quad (6.10.2)$$

1502 Multiplying the total rate of change of voltage by the direct current at which the stack voltages, $U(t_k)$ and $U(t_0)$,
 1503 were determined in polarisation curve measurements, the total rate of change of power ($\Delta_{\text{tot}}^k P$) is calculated,
 1504 whether positive (degradation) or negative (improvement), as follows

$$1505 \quad \Delta_{\text{tot}}^k P \text{ (mW/h)} = \frac{P(t_k) \text{ (kW)} - P(t_0) \text{ (kW)}}{t_k \text{ (h)} - t_0 \text{ (h)}} \cdot f_{\text{compr}} \cdot 10^6 \text{ mV/kV} \quad (6.10.3)$$

1506 where the power at t_k and t_0 , $P(t_k)$ and $P(t_0)$, are calculated as follows

$$1507 \quad P(t_k) \text{ (kW)} = U(t_k) \text{ (kV)} \cdot I_{\text{dc}}(t_k) \text{ (A)} \quad \text{and} \quad (6.10.4a)$$

$$1508 \quad P(t_0) \text{ (kW)} = U(t_0) \text{ (kV)} \cdot I_{\text{dc}}(t_0) \text{ (A)}; \quad (6.10.4b)$$

1509 $I_{\text{dc}}(t_k)$ and $I_{\text{dc}}(t_0)$ is the direct current at t_k and t_0 , respectively. In principle, the current applied during the
 1510 polarisation curve measurements at t_k and t_0 should be the same but measured current values may eventually
 1511 deviate slightly from this assumption. Accordingly, the relative rate of change of power ($\Delta_{\text{rel}}^k P$) is calculated,
 1512 whether positive (degradation) or negative (improvement), as follows

$$1513 \quad \Delta_{\text{rel}}^k P \text{ (%) } = \left(\frac{P(t_k) \text{ (kW)}}{P(t_0) \text{ (kW)}} - 1 \right) \cdot \frac{1000 \text{ (h)} \cdot f_{\text{compr}}}{t_k \text{ (h)}} \cdot 100 \text{ \%}. \quad (6.10.5)$$

1514 Note, the total rate of change of power and the relative rate of change of power are useful KPIs when
 1515 comparing performance degradation of WE stacks determined under potentiostatic conditions as oppose to the
 1516 recommended galvanostatic conditions.

1517 Importantly, equation (6.10.1) and equation (6.10.2) determine the performance degradation of a WE stack
 1518 only in terms of absolute and relative voltage deviation, respectively. They do not encompass accompanying
 1519 changes in the hydrogen output rate, see equation (6.7.1), due to leakage and gas crossover, if any.

1520 Then, the performance degradation of a WE stack should also be assessed from the difference in the stack
 1521 voltage at t_k normalised by the volumetric flow rate of hydrogen, see equation (6.7.2), at that instant ($q_{\text{V,H}_2}(t_k)$)
 1522 and the stack voltage at t_0 normalised by the volumetric flow rate of hydrogen at the latter instant ($q_{\text{V,H}_2}(t_0)$)
 1523 being the total change of voltage per unit of hydrogen volumetric flow rate ($\Delta_{q_{\text{V,H}_2}}^k U$) as well as the difference
 1524 in the stack voltage at t_k normalised by the mass flow rate of hydrogen, see equation (6.7.4), at that instant
 1525 ($q_{\text{m,H}_2}(t_k)$) and the stack voltage at t_0 normalised by the mass flow rate of hydrogen at the latter instant
 1526 ($q_{\text{m,H}_2}(t_0)$) being the total change of voltage per unit of hydrogen mass flow rate ($\Delta_{q_{\text{m,H}_2}}^k U$) calculated, whether
 1527 positive (degradation) or negative (improvement), as follows (Suermann *et al.*, 2019)

$$1528 \quad \Delta_{q_{\text{V,H}_2}}^k U \text{ (}\mu\text{V/m}^3_{\text{H}_2}/\text{h)} = \left(\frac{U(t_k) \text{ (kV)}}{q_{\text{V,H}_2}(t_k) \text{ (m}^3/\text{h)}} - \frac{U(t_0) \text{ (kV)}}{q_{\text{V,H}_2}(t_0) \text{ (m}^3/\text{h)}} \right) \cdot f_{\text{compr}} \cdot 10^9 \mu\text{V/kV} \quad \text{and} \quad (6.10.6a)$$

⁽³⁸⁾ The SRIA 2024 and 2030 targets are 0,11 % and 0,10 % of performance degradation per one thousand hours of AWE operation. These values are 0,9 % and 0,5 % for AEMEL and 0,15 % and 0,12 % for PEMEL (see footnote 25 and Table 6.1).

⁽³⁹⁾ In case the total rate of change of voltage is determined for more than one value of stack current density, stack operating temperature or pressure of hydrogen, appropriate indices should be added to $\Delta_{\text{tot}}^k U$ and similarly to $\Delta_{\text{rel}}^k U$ given by equation (6.10.2), $\Delta_{\text{tot}}^k P$ given by equation (6.10.3) and $\Delta_{\text{rel}}^k P$ given by equation (6.10.5), $\Delta_{q_{\text{V,H}_2}}^k U$ and $\Delta_{q_{\text{m,H}_2}}^k U$ given by equation (6.10.6) as well as $\Delta_{q_{\text{V,H}_2}}^k E$ and $\Delta_{q_{\text{m,H}_2}}^k E$ given by equation (6.10.7).

⁽⁴⁰⁾ The compression factor is unity for accelerated lifetime testing.

$$\Delta_{q_{m,H_2}}^k U \text{ (}\mu\text{V/kg}_{H_2}\text{/h)} = \left(\frac{U(t_k) \text{ (kV)}}{q_{m,H_2}(t_k) \text{ (kg/h)}} - \frac{U(t_0) \text{ (kV)}}{q_{m,H_2}(t_0) \text{ (kg/h)}} \right) \cdot f_{\text{compr}} \cdot 10^9 \mu\text{V/kV}. \quad (6.10.6b)$$

As for the stack voltages used in equation (6.10.1), both type of hydrogen flow rates (section 6.7.8) are determined as average values simultaneously with their corresponding stack voltages during polarisation curve measurements. Then, the total change of energy per unit of volume of hydrogen ($\Delta_{q_{v,H_2}}^k E$) and the total change of energy per unit of mass of hydrogen ($\Delta_{q_{m,H_2}}^k E$) are calculated, whether positive (degradation) or negative (improvement), as follows

$$\Delta_{q_{v,H_2}}^k E \text{ (mWh/m}_{H_2}^3\text{/h)} = \left(\frac{P(t_k) \text{ (kW)}}{q_{v,H_2}(t_k) \text{ (m}^3\text{/h)}} - \frac{P(t_0) \text{ (kW)}}{q_{v,H_2}(t_0) \text{ (m}^3\text{/h)}} \right) \cdot f_{\text{compr}} \cdot 10^6 \text{ mWh/kW} \text{ and} \quad (6.10.7a)$$

$$\Delta_{q_{m,H_2}}^k E \text{ (mWh/kg}_{H_2}\text{/h)} = \left(\frac{P(t_k) \text{ (kW)}}{q_{m,H_2}(t_k) \text{ (kg/h)}} - \frac{P(t_0) \text{ (kW)}}{q_{m,H_2}(t_0) \text{ (kg/h)}} \right) \cdot f_{\text{compr}} \cdot 10^6 \text{ mWh/kW}. \quad (6.10.7b)$$

The uniformity of the performance degradation of a WE stack in terms of cell voltages may be assessed by the total rate of change of mean absolute error average cell voltage ($\Delta_{\text{tot}}^k \text{MAE } \overline{U_{\text{cell}}}$), the relative rate of change of mean absolute error average cell voltage ($\Delta_{\text{rel}}^k \text{MAE } \overline{U_{\text{cell}}}$), the total rate of change of standard deviation of average cell voltage ($\Delta_{\text{tot}}^k \text{SD } \overline{U_{\text{cell}}}$) and the relative rate of change of standard deviation of average cell voltage ($\Delta_{\text{rel}}^k \text{SD } \overline{U_{\text{cell}}}$) calculated as follows ⁽⁴¹⁾

$$\Delta_{\text{tot}}^k \text{MAE } \overline{U_{\text{cell}}} \text{ (}\mu\text{V/h)} = \frac{\text{MAE } \overline{U_{\text{cell}}}(t_k) \text{ (mV)} - \text{MAE } \overline{U_{\text{cell}}}(t_0) \text{ (mV)}}{t_k \text{ (h)} - t_0 \text{ (h)}} \cdot f_{\text{compr}} \cdot 10^3 \mu\text{V/mV}, \quad (6.10.8a)$$

$$\Delta_{\text{rel}}^k \text{MAE } \overline{U_{\text{cell}}} \text{ (%) } = \left(\frac{\overline{U_{\text{cell}}}(t_0) \text{ (V)} \cdot \text{MAE } \overline{U_{\text{cell}}}(t_k) \text{ (mV)}}{\overline{U_{\text{cell}}}(t_k) \text{ (V)} \cdot \text{MAE } \overline{U_{\text{cell}}}(t_0) \text{ (mV)}} - 1 \right) \cdot \frac{1000 \text{ (h)} \cdot f_{\text{compr}}}{t_k \text{ (h)}} \cdot 100 \%, \quad (6.10.8b)$$

$$\Delta_{\text{tot}}^k \text{SD } \overline{U_{\text{cell}}} \text{ (}\mu\text{V/h)} = \frac{\text{SD } \overline{U_{\text{cell}}}(t_k) \text{ (mV)} - \text{SD } \overline{U_{\text{cell}}}(t_0) \text{ (mV)}}{t_k \text{ (h)} - t_0 \text{ (h)}} \cdot f_{\text{compr}} \cdot 10^3 \mu\text{V/mV} \text{ and} \quad (6.10.8c)$$

$$\Delta_{\text{rel}}^k \text{SD } \overline{U_{\text{cell}}} \text{ (%) } = \left(\frac{\overline{U_{\text{cell}}}(t_0) \text{ (V)} \cdot \text{SD } \overline{U_{\text{cell}}}(t_k) \text{ (mV)}}{\overline{U_{\text{cell}}}(t_k) \text{ (V)} \cdot \text{SD } \overline{U_{\text{cell}}}(t_0) \text{ (mV)}} - 1 \right) \cdot \frac{1000 \text{ (h)} \cdot f_{\text{compr}}}{t_k \text{ (h)}} \cdot 100 \%; \quad (6.10.8d)$$

$\text{MAE } \overline{U_{\text{cell}}}(t_k)$, $\text{SD } \overline{U_{\text{cell}}}(t_k)$ and $\overline{U_{\text{cell}}}(t_k)$ are respectively the mean absolute error of average cell voltage, standard deviation of average cell voltage and average cell voltage at t_k while $\text{MAE } \overline{U_{\text{cell}}}(t_0)$, $\text{SD } \overline{U_{\text{cell}}}(t_0)$ and $\overline{U_{\text{cell}}}(t_0)$ are the same quantities but at t_0 . They are calculated from the cell voltages determined during polarisation curve measurements.

Further, the performance degradation of a WE stack for a given stack current density, stack operating temperature and pressure of hydrogen may be assessed by the total rate of change of area-specific resistance ($\Delta_{\text{tot}}^k R_{\text{ASR}}$) and the total rate of change of ohmic resistance ($\Delta_{\text{tot}}^k R_{\Omega}$), whether positive (degradation) or negative (improvement), calculated as follows ⁽⁴²⁾

$$\Delta_{\text{tot}}^k R_{\text{ASR}} \text{ (m}\Omega\text{.cm}^2\text{/h)} = \frac{R_{\text{ASR}}(t_k) \text{ (m}\Omega\text{.cm}^2) - R_{\text{ASR}}(t_0) \text{ (m}\Omega\text{.cm}^2)}{t_k \text{ (h)} - t_0 \text{ (h)}} \cdot f_{\text{compr}} \text{ and} \quad (6.10.9a)$$

$$\Delta_{\text{tot}}^k R_{\Omega} \text{ (m}\Omega\text{/h)} = \frac{R_{\Omega}(t_k) \text{ (m}\Omega) - R_{\Omega}(t_0) \text{ (m}\Omega)}{t_k \text{ (h)} - t_0 \text{ (h)}} \cdot f_{\text{compr}}; \quad (6.10.9b)$$

$R_{\text{ASR}}(t_k)$ and $R_{\text{ASR}}(t_0)$ are the area-specific resistances at respectively t_k and t_0 while $R_{\Omega}(t_k)$ and $R_{\Omega}(t_0)$ are the ohmic resistances at these two instants. They are determined from EIS measurements (section 6.7.12) conducted under galvanostatic conditions. The relative rate of change of area-specific resistance ($\Delta_{\text{rel}}^k R_{\text{ASR}}$) and the relative rate of change of ohmic resistance ($\Delta_{\text{rel}}^k R_{\Omega}$) corresponding to a minimum of one thousand hours of stack operation times the compression factor, whether positive (degradation) or negative (improvement), are calculated as follows

$$\Delta_{\text{rel}}^k R_{\text{ASR}} \text{ (%) } = \left(\frac{R_{\text{ASR}}(t_k) \text{ (m}\Omega\text{.cm}^2)}{R_{\text{ASR}}(t_0) \text{ (m}\Omega\text{.cm}^2)} - 1 \right) \cdot \frac{1000 \text{ (h)} \cdot f_{\text{compr}}}{t_k \text{ (h)}} \cdot 100 \% \text{ and} \quad (6.10.10a)$$

⁽⁴¹⁾ In case the total rate of change of mean absolute error average cell voltage, the relative rate of change of mean absolute error average cell voltage, the total rate of change of standard deviation of average cell voltage and the relative rate of change of standard deviation of average cell voltage are determined for more than one value of stack current density, stack operating temperature or pressure of hydrogen, appropriate indices should be added to $\Delta_{\text{tot}}^k \text{MAE } \overline{U_{\text{cell}}}$, $\Delta_{\text{rel}}^k \text{MAE } \overline{U_{\text{cell}}}$, $\Delta_{\text{tot}}^k \text{SD } \overline{U_{\text{cell}}}$ and $\Delta_{\text{rel}}^k \text{SD } \overline{U_{\text{cell}}}$ given by equation (6.10.8).

⁽⁴²⁾ In case the total rate of change of area-specific resistance and the total rate of change of ohmic resistance are determined for more than one value of stack current density, stack operating temperature or pressure of hydrogen, appropriate indices should be added to $\Delta_{\text{tot}}^k R_{\text{ASR}}$ and $\Delta_{\text{tot}}^k R_{\Omega}$ given by equation (6.10.9) and similarly to $\Delta_{\text{rel}}^k R_{\text{ASR}}$ and $\Delta_{\text{rel}}^k R_{\Omega}$ given by equation (6.10.10).

$$\Delta_{\text{rel}}^k R_{\Omega} (\%) = \left(\frac{R_{\Omega}(t_k) (\text{m}\Omega)}{R_{\Omega}(t_0) (\text{m}\Omega)} - 1 \right) \cdot \frac{1000 (\text{h}) \cdot f_{\text{compr}}}{t_k (\text{h})} \cdot 100 \% \quad (6.10.10b)$$

For a given input current (input voltage or input electric power) and stack operating temperature, the durability of a WE stack at an elapsed time interval t_k is assessed from the difference of the energy efficiency based on HHV under SATP conditions of hydrogen ($\eta_{\text{HHV,e}}^0$), the energy efficiency based on LHV under SATP conditions of hydrogen ($\eta_{\text{LHV,e}}^0$), the electrical efficiency based on HHV under SATP conditions of hydrogen ($\eta_{\text{HHV,e}}^0$) and the electrical efficiency based on LHV under SATP conditions of hydrogen ($\eta_{\text{LHV,e}}^0$) at t_k and t_0 by calculating the total rate of change of energy efficiency based on HHV under SATP conditions of hydrogen ($\Delta_{\text{tot}}^k \eta_{\text{HHV,e}}^0$), the total rate of change of energy efficiency based on LHV under SATP conditions of hydrogen ($\Delta_{\text{tot}}^k \eta_{\text{LHV,e}}^0$), the total rate of change of electrical efficiency based on HHV under SATP conditions of hydrogen ($\Delta_{\text{tot}}^k \eta_{\text{HHV,el}}^0$) and the total rate of change of electrical efficiency based on LHV under SATP conditions of hydrogen ($\Delta_{\text{tot}}^k \eta_{\text{LHV,el}}^0$), whether positive (degradation) or negative (improvement), as follows ⁽⁴³⁾

$$\Delta_{\text{tot}}^k \eta_{\text{HHV,e}}^0 (\%/h) = \frac{\eta_{\text{HHV,e}}^0(t_k) (\%) - \eta_{\text{HHV,e}}^0(t_0) (\%)}{t_k (\text{h}) - t_0 (\text{h})} \cdot f_{\text{compr}}, \quad (6.10.11a)$$

$$\Delta_{\text{tot}}^k \eta_{\text{LHV,e}}^0 (\%/h) = \frac{\eta_{\text{LHV,e}}^0(t_k) (\%) - \eta_{\text{LHV,e}}^0(t_0) (\%)}{t_k (\text{h}) - t_0 (\text{h})} \cdot f_{\text{compr}}, \quad (6.10.11b)$$

$$\Delta_{\text{tot}}^k \eta_{\text{HHV,el}}^0 (\%/h) = \frac{\eta_{\text{HHV,el}}^0(t_k) (\%) - \eta_{\text{HHV,el}}^0(t_0) (\%)}{t_k (\text{h}) - t_0 (\text{h})} \cdot f_{\text{compr}} \quad \text{and} \quad (6.10.11c)$$

$$\Delta_{\text{tot}}^k \eta_{\text{LHV,el}}^0 (\%/h) = \frac{\eta_{\text{LHV,el}}^0(t_k) (\%) - \eta_{\text{LHV,el}}^0(t_0) (\%)}{t_k (\text{h}) - t_0 (\text{h})} \cdot f_{\text{compr}}; \quad (6.10.11d)$$

$\eta_{\text{HHV,e}}^0(t_k)$, $\eta_{\text{LHV,e}}^0(t_k)$, $\eta_{\text{HHV,el}}^0(t_k)$ and $\eta_{\text{LHV,el}}^0(t_k)$ are respectively the energy efficiency based on HHV under SATP conditions of hydrogen, the energy efficiency based on LHV under SATP conditions of hydrogen, the electrical efficiency based on HHV under SATP conditions of hydrogen and the electrical efficiency based on LHV under SATP conditions of hydrogen at t_k while $\eta_{\text{HHV,e}}^0(t_0)$, $\eta_{\text{LHV,e}}^0(t_0)$, $\eta_{\text{HHV,el}}^0(t_0)$ and $\eta_{\text{LHV,el}}^0(t_0)$ are these efficiencies at t_0 . At both instants, t_k and t_0 , these energy efficiencies are determined in accordance with section 6.7.13 during polarisation curve measurements. The relative rate of change of energy efficiency based on HHV under SATP conditions of hydrogen ($\Delta_{\text{rel}}^k \eta_{\text{HHV,e}}^0$), the relative rate of change of energy efficiency based on LHV under SATP conditions of hydrogen ($\Delta_{\text{rel}}^k \eta_{\text{LHV,e}}^0$), the relative rate of change of electrical efficiency based on HHV under SATP conditions of hydrogen ($\Delta_{\text{rel}}^k \eta_{\text{HHV,el}}^0$) and the relative rate of change of electrical efficiency based on LHV under SATP conditions of hydrogen ($\Delta_{\text{rel}}^k \eta_{\text{LHV,el}}^0$) corresponding to a minimum of one thousand hours of stack operation times the compression factor are calculated, whether positive (degradation) or negative (improvement), as follows

$$\Delta_{\text{rel}}^k \eta_{\text{HHV,e}}^0 (\%) = \left(\frac{\eta_{\text{HHV,e}}^0(t_k) (\%)}{\eta_{\text{HHV,e}}^0(t_0) (\%)} - 1 \right) \cdot \frac{1000 (\text{h}) \cdot f_{\text{compr}}}{t_k (\text{h})} \cdot 100 (\%), \quad (6.10.12a)$$

$$\Delta_{\text{rel}}^k \eta_{\text{LHV,e}}^0 (\%) = \left(\frac{\eta_{\text{LHV,e}}^0(t_k) (\%)}{\eta_{\text{LHV,e}}^0(t_0) (\%)} - 1 \right) \cdot \frac{1000 (\text{h}) \cdot f_{\text{compr}}}{t_k (\text{h})} \cdot 100 (\%), \quad (6.10.12b)$$

$$\Delta_{\text{rel}}^k \eta_{\text{HHV,el}}^0 (\%) = \left(\frac{\eta_{\text{HHV,el}}^0(t_k) (\%)}{\eta_{\text{HHV,el}}^0(t_0) (\%)} - 1 \right) \cdot \frac{1000 (\text{h}) \cdot f_{\text{compr}}}{t_k (\text{h})} \cdot 100 (\%) \quad \text{and} \quad (6.10.12c)$$

$$\Delta_{\text{rel}}^k \eta_{\text{LHV,el}}^0 (\%) = \left(\frac{\eta_{\text{LHV,el}}^0(t_k) (\%)}{\eta_{\text{LHV,el}}^0(t_0) (\%)} - 1 \right) \cdot \frac{1000 (\text{h}) \cdot f_{\text{compr}}}{t_k (\text{h})} \cdot 100 (\%). \quad (6.10.12d)$$

The input direct current (input DC voltage or input electric power) and the stack operating temperature are their rated values given by the stack manufacturer unless otherwise specified in the test plan.

⁽⁴³⁾ In case the total rate of change of energy efficiency based on HHV under SATP conditions of hydrogen, the total rate of change of energy efficiency based on LHV under SATP conditions of hydrogen, the total rate of change of electrical efficiency based on HHV under SATP conditions of hydrogen and the total rate of change of electrical efficiency based on LHV under SATP conditions of hydrogen are determined for more than one value of input current (input voltage, input electric power) or stack current density, appropriate indices should be added to $\Delta_{\text{tot}}^k \eta_{\text{HHV,e}}^0$, $\Delta_{\text{tot}}^k \eta_{\text{LHV,e}}^0$, $\Delta_{\text{tot}}^k \eta_{\text{HHV,el}}^0$ and $\Delta_{\text{tot}}^k \eta_{\text{LHV,el}}^0$ given by equation (6.10.11) and similarly to $\Delta_{\text{rel}}^k \eta_{\text{HHV,e}}^0$, $\Delta_{\text{rel}}^k \eta_{\text{LHV,e}}^0$, $\Delta_{\text{rel}}^k \eta_{\text{HHV,el}}^0$ and $\Delta_{\text{rel}}^k \eta_{\text{LHV,el}}^0$ given by equation (6.10.12).

7 Presentation of test results

1597 Table 7.1 lists the TOPs as results of performance tests (section 6.7) and durability test (section 6.9).

Table 7.1: Test output parameter as test results

TOP (unit)	Description	Test method
<i>Performance tests</i>		
$P_{el, in}$ (kW)	input electric power	section 6.7.1
I_{in} (A)	input current	section 6.7.2
U_{in} (kV)	input voltage	section 6.7.3
P_{th} (kW)	thermal power	section 6.7.4
P_{compr} (kW)	power of compression	section 6.7.5
t_{resp} (s)	response time	section 6.7.6
E_{ramp} (kJ/s)	ramp energy	section 6.7.6
pH _{lye}	pH value of lye solution ⁽¹⁾	section 6.7.7
$\sigma_{el, lye}$ (mS)	electrical conductivity of lye solution ⁽¹⁾	section 6.7.7
pH _w	pH value of liquid water ⁽²⁾	section 6.7.7
$\sigma_{el, w}$ (mS)	electrical conductivity of liquid water ⁽²⁾	section 6.7.7
q_{n, H_2} (mol/h)	molar flow rate of hydrogen	section 6.7.8
x_{n, H_2} (mol/mol)	molar concentration of hydrogen	section 6.7.8
q_{V, H_2} (mol/h)	volumetric flow rate of hydrogen	section 6.7.8
q_{m, H_2} (mol/h)	mass flow rate of hydrogen	section 6.7.8
q_{n, O_2} (mol/h)	molar flow rate of oxygen	section 6.7.9
x_{n, O_2} (mol/mol)	molar concentration of oxygen	section 6.7.9
c_F (μ g/l)	fluoride concentration ⁽³⁾	section 6.7.10
c_{PFAS} (ng/l)	PFAS concentration ⁽³⁾	section 6.7.10
c_{PAH} (ng/l)	PAH concentration ⁽²⁾	section 6.7.10
c_{Ca} (μ g/l)	calcium concentration	section 6.7.10
c_{Cl} (μ g/l)	chloride concentration	section 6.7.10
c_{Cu} (μ g/l)	copper concentration	section 6.7.10
c_{Fe} (μ g/l)	iron concentration	section 6.7.10
c_K (μ g/l)	potassium concentration	section 6.7.10
c_{Mg} (μ g/l)	magnesium concentration	section 6.7.10
c_{Na} (μ g/l)	sodium concentration	section 6.7.10
c_{Ni} (μ g/l)	nickel concentration	section 6.7.10
I_{stack} (A)	stack current	section 6.7.11
J_{stack} (A/cm ²)	stack current density	section 6.7.11
U_{stack} (kV)	stack voltage	section 6.7.11
$U_{cell, n}$ (V)	voltage of cell n	section 6.7.11
\overline{U}_{cell} (V)	average cell voltage	section 6.7.11
$MAE \overline{U}_{cell}$ (mV)	mean absolute error of average cell voltage	section 6.7.11
$SD \overline{U}_{cell}$ (mV)	standard deviation of average cell voltage	section 6.7.11
R_{Ω} (Ω)	ohmic resistance	section 6.7.12
R_{ASR} (m Ω .cm ²)	area-specific resistance ⁽⁴⁾	section 6.7.12
$\eta_{HHV, e}^0$ (%)	energy efficiency based on HHV under SATP conditions	section 6.7.13
$\eta_{LHV, e}^0$ (%)	energy efficiency based on LHV under SATP conditions	section 6.7.13
$\eta_{HHV, el}^0$ (%)	electrical efficiency based on HHV under SATP conditions	section 6.7.13
$\eta_{LHV, el}^0$ (%)	electrical efficiency based on LHV under SATP conditions	section 6.7.13
<i>Durability tests</i>		
$\Delta_{tot}^k U$ (μ V/h)	total rate of change of voltage	section 6.10
$\Delta_{rel}^k U$ (μ V/h)	relative rate of change of voltage	section 6.10
$\Delta_{tot}^k P$ (mW/h)	total rate of change of power	section 6.10
$\Delta_{rel}^k P$ (%)	relative rate of change of power	section 6.10
$\Delta_{q_{V, H_2}}^k U$ (μ V/m ³ _{H₂} /h)	total change of voltage per unit of hydrogen volumetric flow rate	section 6.10
$\Delta_{q_{m, H_2}}^k U$ (μ V/kg _{H₂} /h)	total change of voltage per unit of hydrogen mass flow rate	section 6.10
$\Delta_{q_{V, H_2}}^k E$ (mWh/m ³ _{H₂})	total change of energy per unit of volume of hydrogen	section 6.10
$\Delta_{q_{m, H_2}}^k E$ (mWh/kg _{H₂})	total change of energy per unit of mass of hydrogen	section 6.10

Continue to next page

Table 7.1 – continued from previous page

$\Delta_{\text{tot}}^k \text{MAE} \frac{1}{\bar{U}_{\text{cell}}} (\mu\text{V}/\text{h})$	total rate of change of mean absolute error average cell voltage	section 6.10
$\Delta_{\text{rel}}^k \text{MAE} \frac{1}{\bar{U}_{\text{cell}}} (\%)$	relative rate of change of mean absolute error average cell voltage	section 6.10
$\Delta_{\text{tot}}^k \text{SD} \frac{1}{\bar{U}_{\text{cell}}} (\mu\text{V}/\text{h})$	total rate of change of standard deviation of average cell voltage	section 6.10
$\Delta_{\text{rel}}^k \text{SD} \frac{1}{\bar{U}_{\text{cell}}} (\%)$	relative rate of change of standard deviation of average cell voltage	section 6.10
$\Delta_{\text{tot}}^k R_{\text{ASR}} (\text{m}\Omega \cdot \text{cm}^2/\text{h})$	total rate of change of area-specific resistance	section 6.10
$\Delta_{\text{tot}}^k R_{\Omega} (\text{m}\Omega/\text{h})$	total rate of change of ohmic resistance	section 6.10
$\Delta_{\text{rel}}^k R_{\text{ASR}} (\%)$	relative rate of change of area-specific resistance	section 6.10
$\Delta_{\text{rel}}^k R_{\Omega} (\%)$	relative rate of change of ohmic resistance	section 6.10
$\Delta_{\text{tot}}^k \eta_{\text{HHV,e}}^0 (\%/h)$	total rate of change of energy efficiency based on HHV under SATP conditions of hydrogen	section 6.10
$\Delta_{\text{rel}}^k \eta_{\text{HHV,e}}^0 (\%)$	relative rate of change of energy efficiency based on HHV under SATP conditions of hydrogen	section 6.10
$\Delta_{\text{tot}}^k \eta_{\text{LHV,e}}^0 (\%/h)$	total rate of change of energy efficiency based on LHV under SATP conditions of hydrogen	section 6.10
$\Delta_{\text{rel}}^k \eta_{\text{LHV,e}}^0 (\%)$	relative rate of change of energy efficiency based on LHV under SATP conditions of hydrogen	section 6.10
$\Delta_{\text{tot}}^k \eta_{\text{HHV,el}}^0 (\%/h)$	total rate of change of electrical efficiency based on HHV under SATP conditions of hydrogen	section 6.10
$\Delta_{\text{rel}}^k \eta_{\text{HHV,el}}^0 (\%)$	relative rate of change of electrical efficiency based on HHV under SATP conditions of hydrogen	section 6.10
$\Delta_{\text{tot}}^k \eta_{\text{LHV,el}}^0 (\%/h)$	total rate of change of electrical efficiency based on LHV under SATP conditions of hydrogen	section 6.10
$\Delta_{\text{rel}}^k \eta_{\text{LHV,el}}^0 (\%)$	relative rate of change of electrical efficiency based on LHV under SATP conditions of hydrogen	section 6.10

1598 *Note:* According to the test plan (section 6.6), TOPs may be obtained as functions of TIPs or other TOPs as well as time (test duration),
 1599 number of operation profiles or sequence(s) of such profiles. By adding appropriate indices to the concerned TOP, TOPs of same type
 1600 are distinguished.

1601 ⁽¹⁾ measured for AWE and AAEMWE stacks

1602 ⁽²⁾ measured for AEMWE and PEMWE stacks

1603 ⁽³⁾ measured for PEMWE stacks

1604 ⁽⁴⁾ The method of R_{if} estimation whether polarisation curve measurements or EIS measurements shall be stated.

1605 *Source:* JRC, 2023

1606 The test results should, as appropriate, be reported along with their standard uncertainties (u) or combined
 1607 standard uncertainties (u_c) in accordance with the GUM (JCGM, 2008, JCGM, 2009, JCGM, 2020).

1608 In addition to tabulated test results, TOPs of durability tests should be presented graphically, for example, to
 1609 show their evolution with time or the number and sequence(s) of operation profiles. Their standard uncertainties
 1610 or combined standard uncertainties should constitute error bars for a specified level of confidence (JCGM, 2008).

1611 8 Conclusions with final remarks

1612 This report proposes testing protocols for accelerated stress testing of low-temperature WE stacks to determine
1613 their performance degradation when used in WE systems generating bulk amounts of clean hydrogen in P-to-
1614 H₂ applications for H₂-to-P, hydrogen-to-mobility (H₂-to-M) and H₂-to-I processes using fluctuating electricity
1615 from RES such as PV and WT electric power. They rely on test methods of ISO and IEC standards and testing
1616 procedures developed as part of the EU water electrolysis harmonisation activities.

1617 These protocols allow for an adequate comparison of WEL technologies in stacks, whether of AEC type in
1618 AWE, AEMEC type in AEMWE and AAEMWE, or PEMEC type in PEMWE. They also allow to compare the performance
1619 degradation of different stacks of the same type but different in design, configuration and WEC materials used.
1620 Intended for use by the research community and industry alike, these protocols provide built-in flexibility. In
1621 fact, performance tests may selectively be performed, and in addition to the exemplified RES-based operation
1622 profiles, application-oriented duty cycles may be employed in durability tests.

1623 Also, the user is free to substitute one or another test method in a particular campaign when deemed more
1624 appropriate for the intended use of the WE stack in the application concerned. All tests shall be conducted
1625 safely (Annex A) and with due care, the recording of all relevant test parameters, whether TIPs or TOPs, shall be
1626 followed as required, and the reported test results (Annex B) shall be stated along with their uncertainties.

1627 The application of various stress parameters and their combination to WE stacks during an AST campaign,
1628 the use of a structured DoE approach may not necessarily guarantee the induction of degradation phenomena
1629 previously identified in stacks tested under similar operating conditions and dynamic operation modes. However,
1630 given the wealth of test data gathered from WE stacks subjected to accelerated stress testing, advanced
1631 statistical analysis (IEC, 2010, IEC, 2011, IEC, 2017b) and physics-based modelling could potentially unveil
1632 performance degradation patterns in WE stacks and establish correlations with the applied stressing operating
1633 conditions.

1634 This could be achieved through the effective utilisation of machine learning (ML) (4.2.47) algorithms (Mo-
1635 hamed *et al.*, 2022, Sayed-Ahmed *et al.*, 2024) and other artificial intelligence (AI) (4.2.11) techniques (Chavez-
1636 Ramirez *et al.*, 2011, Jha *et al.*, 2017, Bahr *et al.*, 2020) on the acquired test results which should always be
1637 made open access. A data-driven approach holds promise for developing transfer functions that express the
1638 relationship between WE stack performance degradation, applied stress parameters, and the reduction of test
1639 duration. This aligns with the ultimate goal of accelerated stress testing, which is to minimise R&D costs and
1640 expedite the maturation of WE stacks for cost-effective, long-term operation to generate clean hydrogen in bulk
1641 amounts using electricity from RESs.

References

- 1642
- 1643 Carrara, S., Bobba, S., Blagoeva, D., Dias, P. A., Cavalli, A., Georgitzikis, K., Grohol, M., Itul, A., Kuzov, T., Latunussa,
1644 C., Lyons, L., Malano, G., Maury, T., Arce, A. P., Somers, J., Telsnig, T., Veeh, C., Wittmer, D., Black, C., Pennington,
1645 D. and Christou, M., 'Supply chain analysis and material demand forecast in strategic technologies and sectors
1646 in the EU: a foresight study', JRC Science for Policy report EUR 31437 EN, European Commission, 2023. doi:
1647 10.2760/386650.
- 1648 Cartaxo, M., Fernandes, J., Gomes, M., Pinho, H., Nunes, V. and Coelho, P., 'Hydrogen production via wastewater
1649 electrolysis – an integrated approach review', In 'Innovations in Smart Cities Applications', , edited by M. B. Ahmed,
1650 A. A. Boudhir, . R. Karas, V. Jain, and S. Mellouli Vol. 5. Springer International Publishing, Cham, pp. 671–680.
1651 doi:10.1007/978-3-030-94191-8_54. URL <http://hdl.handle.net/10400.26/39663>.
- 1652 Chavez-Ramirez, A. U., Munoz-Guerrero, R., Sanchez-Huerta, V., Ramirez-Arredondo, J. M., Ornelas, R., Arriaga,
1653 L. G., Siracusano, S., Brunaccini, G., Napoli, G., Antonucci, V. and Aricó, A. S., 'Dynamic model of a pem electrolyzer
1654 based on artificial neural networks', *Journal of New Materials for Electrochemical Systems*, Vol. 14, No 2, 2011,
1655 pp. 113–119. doi:10.14447/jnmes.v14i2.119.
- 1656 Clapp, M., Zalitis, C. M. and Ryan, M., 'Perspectives on current and future iridium demand and iridium oxide catalysts
1657 for PEM water electrolysis', *Catalysis Letters*, Vol. 420, 2023, p. 114140. doi:10.1016/j.cattod.2023.114140.
- 1658 Elia Transmission Belgium SA, 'Grid data Open data'. online, 05 August 2023. URL <https://opendata.elia.be>.
- 1659 CNR, 'Enhanced performance and cost-effective materials for long-term operation of PEM water electrolyzers
1660 coupled to renewable power sources', Project information, CORDIS, 2012. URL [https://cordis.europa.eu/
1661 project/id/300081](https://cordis.europa.eu/project/id/300081).
- 1662 CNR, 'High Performance PEM Electrolyzer for Cost-effective Grid Balancing Applications', Project information,
1663 CORDIS, 2016. doi:10.3030/700008. URL <https://cordis.europa.eu/project/id/700008>.
- 1664 CNR, 'Anion Exchange Membrane Electrolysis for Renewable Hydrogen Production on a Wide-Scale', Project
1665 information, CORDIS, 2020. doi:10.3030/875024. URL <https://cordis.europa.eu/project/id/875024>.
- 1666 DLR, 'Novel modular stack design for high pressure PEM water electrolyzer technology with wide operation range
1667 and reduced cost', Project information, CORDIS, 2018. doi:10.3030/779478. URL [https://cordis.europa.
1668 eu/project/id/779478](https://cordis.europa.eu/project/id/779478).
- 1669 DLR, 'Cost-effective PROton Exchange MEmbrane WaTer Electrolyser for Efficient and Sustainable Power-to-H2
1670 Technology', Project information, CORDIS, 2020a. doi:10.3030/862253. URL [https://cordis.europa.eu/
1671 project/id/862253](https://cordis.europa.eu/project/id/862253).
- 1672 DLR, 'Next Generation Alkaline Membrane Water Electrolyzers with Improved Components and Materials', Project
1673 information, CORDIS, 2020b. doi:10.3030/875118. URL <https://cordis.europa.eu/project/id/875118>.
- 1674 JCGM, 'Evaluation of measurement data - Guide to the expression of uncertainty in measurement', GUM: Guide
1675 to the Expression of Uncertainty in Measurement JCGM 100:2008, Joint Committee for Guides in Metrology,
1676 2008. URL https://www.bipm.org/utils/common/documents/jcgm/JCGM_100_2008_E.pdf.
- 1677 JCGM, 'Evaluation of measurement data - An introduction to the Guide to the expression of uncertainty in
1678 measurement and related documents', GUM: Guide to the Expression of Uncertainty in Measurement JCGM
1679 104:2009, Joint Committee for Guides in Metrology, 2009. URL [https://www.bipm.org/documents/20126/
1680 2071204/JCGM_104_2009.pdf](https://www.bipm.org/documents/20126/2071204/JCGM_104_2009.pdf).
- 1681 JCGM, 'Guide to the expression of uncertainty in measurement - Part 6: Developing and using measurement
1682 models', GUM: Guide to the Expression of Uncertainty in Measurement JCGM GUM-6:2020, Joint Committee for
1683 Guides in Metrology, 2020. URL [https://www.bipm.org/documents/20126/2071204/JCGM_GUM_6_2020.
1684 pdf/d4e77d99-3870-0908-ff37-c1b6a230a337?version=1.8&t=1659083073972&download=true](https://www.bipm.org/documents/20126/2071204/JCGM_GUM_6_2020.pdf/d4e77d99-3870-0908-ff37-c1b6a230a337?version=1.8&t=1659083073972&download=true).
- 1685 Bahr, M., Gusak, A., Stypka, S. and Oberschachtsiek, B., 'Artificial neural networks for aging simulation of
1686 electrolysis stacks', *Chemie-Ingenieur-Technik*, Vol. 92, 10 2020, pp. 1610–1617. doi:10.1002/cite.202000089.
- 1687 Fitzek, K., de Haart, U., Fang, Q. and Lehnert, W., 'High-frequency features in the distribution of relaxation times
1688 related to frequency dispersion effects in SOFCs', *Journal of the Electrochemical Society*, Vol. 169, No 1, 2022,
1689 p. 014501. doi:10.1149/1945-7111/ac4372.
- 1690 Du, N., Roy, C., Peach, R., Turnbull, M., Thiele, S. and Bock, C., 'Anion-exchange membrane water electrolyzers',
1691 *Chemical Reviews*, Vol. 122, No 13, 2022, pp. 11830–11895. doi:10.1021/acs.chemrev.1c00854.

- 1692 Kartci, A., Herencsár, N., Tenreiro Machado, J. and Brančík, L., 'History and progress of fractional-order element
1693 passive emulators: A review', *Radioengineering Proceedings of Czech and Slovak Technical Universities*, Vol. 29,
1694 No 2, 2020, pp. 296–304. doi:10.13164/re.2020.0296.
- 1695 EC, 'COMMUNICATION FROM THE COMMISSION TO THE EUROPEAN PARLIAMENT, THE COUNCIL, THE EUROPEAN
1696 ECONOMIC AND SOCIAL COMMITTEE AND THE COMMITTEE OF THE REGIONS Chemicals Strategy for Sustainability
1697 Towards a Toxic-Free Environment', Communication COM/2020/667 final, European Commission, Brussels (BE),
1698 14 October 2020a. URL <https://eur-lex.europa.eu/legal-content/EN/TXT/?uri=COM:2020:667:FIN>.
- 1699 EC, 'Poly- and perfluoroalkyl substances (PFAS)', Commission staff working document SWD(2020) 249
1700 final, European Commission, Brussels (BE), 14 October 2020b. URL [https://eur-lex.europa.eu/
1701 legal-content/EN/TXT/PDF/?uri=CELEX:52020SC0249](https://eur-lex.europa.eu/legal-content/EN/TXT/PDF/?uri=CELEX:52020SC0249).
- 1702 Suermann, M., Bensmann, B. and Hanke-Rauschenbach, R., 'Degradation of proton exchange membrane (PEM)
1703 water electrolysis cells: Looking beyond the cell voltage increase', *Journal of the Electrochemical Society*, Vol.
1704 166, No 10, 2019, p. F645. doi:10.1149/2.1451910jes.
- 1705 Lettenmeier, P., Wang, R., Abouatallah, R., Helmlly, S., Morawietz, T., Hiesgen, R., Kolb, S., Burggraf, F., Kallo,
1706 J., Gago, A. S. and Friedrich, K. A., 'Durable membrane electrode assemblies for proton exchange membrane
1707 electrolyzer systems operating at high current densities', *Electrochimica Acta*, Vol. 210, 2016, pp. 502–511.
1708 doi:10.1016/j.electacta.2016.04.164.
- 1709 Dizon, A., Schuler, T., Weber, A. Z., Danilovic, N. and Bender, G., 'Advanced voltage break down analysis by
1710 statistical open-source tool case study based on polymer electrolyte water electrolysis', *ECS Meeting Abstracts*,
1711 Vol. MA2022-02, No 39, 2022, p. 1400. doi:10.1149/MA2022-02391400mtgabs.
- 1712 Macdonald, J. R. and Potter, L. D., 'A flexible procedure for analyzing impedance spectroscopy results: Description
1713 and illustrations', *Solid State Ionics*, Vol. 24, No 1, 1987, pp. 61–79. doi:10.1016/0167-2738(87)90068-3.
- 1714 Mohamed, A., Ibrahim, H. and Kim, K., 'Machine learning-based simulation for proton exchange membrane
1715 electrolyzer cell', *Energy Reports*, Vol. 8, 2022, pp. 13425–13437. doi:10.1016/j.egyr.2022.09.135.
- 1716 Tomić, A. Z., Pivac, I. and Barbir, F., 'A review of testing procedures for proton exchange membrane electrolyzer
1717 degradation', *Journal of Power Sources*, Vol. 557, 2023, p. 232569. doi:10.1016/j.jpowsour.2022.232569.
- 1718 Ehlers, J. C., Feidenhans'l, A. A., Therkildsen, K. T. and Larrazábal, G. O., 'Affordable green hydrogen from alkaline
1719 water electrolysis: Key research needs from an industrial perspective', *ACS Energy Letters*, Vol. 8, No 3, 2023,
1720 pp. 1502–1509. doi:10.1021/acseenergylett.2c02897.
- 1721 Malkow, K. T., 'A theory of distribution functions of relaxation times for the deconvolution of immittance data',
1722 *Journal of Electroanalytical Chemistry*, Vol. 838, No 4, 2019, pp. 221–231. URL [https://www.sciencedirect.
1723 com/science/article/pii/S1572665719300670](https://www.sciencedirect.com/science/article/pii/S1572665719300670).
- 1724 Gerhardt, M. R., Pant, L. M., Bui, J. C., Crothers, A. R., Ehlinger, V. M., Fornaciari, J. C., Liu, J. and Weber, A. Z.,
1725 'Method—practices and pitfalls in voltage breakdown analysis of electrochemical energy-conversion systems',
1726 *Journal of the Electrochemical Society*, Vol. 168, No 7, 2021, p. 074503. doi:10.1149/1945-7111/abf061.
- 1727 Shih, A. J., de Oliveira Monteiro, M. C., Dattila, F., Pavesi, D., Philips, M., Marques da Silva, A. H., Vos, R. E., Ojha, K.,
1728 Park, S., van der Heijden, O., Marcandalli, G., Goyal, A., Villalba, M., Chen, X., Gunasooriya, G. T. K. K., McCrum, I.,
1729 Mom, R., López, N. and Koper, M. T. M., 'Water electrolysis', *Nature Reviews Methods Primers*, Vol. 2, 2022, p. 84.
1730 doi:10.1038/s43586-022-00164-0.
- 1731 McPhail, S. J., Frangini, S., Laurencin, J., Effori, E., Abaza, A., Padinjarethil, A. K., Hagen, A., Léon, A., Brisse, A.,
1732 Vladikova, D., Burdin, B., Bianchi, F. R., Bosio, B., Piccardo, P., Spotorno, R., Uchida, H., Polverino, P., Adinolfi,
1733 E. A., Postiglione, F., Lee, J.-H., Moussaoui, H. and Van herle, J., 'Addressing planar solid oxide cell degradation
1734 mechanisms: A critical review of selected components', *Electrochemical Science Advances*, Vol. 2, No 5, 2022, p.
1735 e2100024. doi:10.1002/elsa.202100024.
- 1736 Kumar, S. S. and Lim, H., 'Recent advances in hydrogen production through proton exchange membrane water
1737 electrolysis – a review', *Sustainable Energy Fuels*, Vol. 7, No 15, 2023, pp. 3560–3583. doi:10.1039/D3SE00336A.
- 1738 Huang, J., 'Diffusion impedance of electroactive materials, electrolytic solutions and porous electrodes: Warburg
1739 impedance and beyond', *Electrochimica Acta*, Vol. 281, 2018, pp. 170–188. doi:10.1016/j.electacta.2018.05.136.
- 1740 Becker, H., Murawski, J., Shinde, D. V., Stephens, I. E. L., Hinds, G. and Smith, G., 'Impact of impurities on water
1741 electrolysis: a review', *Sustainable Energy Fuels*, Vol. 7, 2023, pp. 1565–1603. doi:10.1039/D2SE01517J.

- 1742 Allidières, L., Brisse, A., Millet, P., Valentin, S. and Zeller, M., 'On the ability of pem water electrolyzers to
1743 provide power grid services', *International Journal of Hydrogen Energy*, Vol. 44, No 20, 2019, pp. 9690–9700.
1744 doi:10.1016/j.ijhydene.2018.11.186.
- 1745 Kumar, S. S. and Lim, H., 'An overview of water electrolysis technologies for green hydrogen production', *Energy*
1746 *Reports*, Vol. 8, 2022, pp. 13793–13813. doi:10.1016/j.egy.2022.10.127.
- 1747 Reissner, R., Goudis, D., Bourasseau, C., Lacroix, V., Lavaille, G., You, S., Greenhalgh, D. A., Green, B., Abadia,
1748 L., Imboden, C., Marcuello, P. and Bornstein, M., 'Qualifying tests of electrolyzers for grid services - finalized
1749 testing protocol', QualyGrid5 Deliverable D7.9, Deutsches Zentrum für Luft- und Raumfahrt e.V., Commissariat
1750 à l'énergie atomique et aux énergies alternatives, Danmarks Tekniske Universitet, ITM Power plc, Fundación
1751 para el Desarrollo de las Tecnologías del Hidrógeno en Aragón, Hochschule Luzern, Sunfire GmbH, Nel ASA, 30
1752 September 2020. doi:10.5281/zenodo.3937273. URL <https://zenodo.org/record/3937273>.
- 1753 EP and Council, 'Approximation of the laws of the Member States concerning equipment and protective systems
1754 intended for use in potentially explosive atmospheres', Directive 94/9/EC, Publications Office of the European
1755 Union, Brussels (BE), 23 March 1994. URL <http://data.europa.eu/eli/dir/1994/9/oj>. OJ L 100 of
1756 19.4.1994.
- 1757 EP and Council, 'General Product Safety', Directive 2001/95/EC, Publications Office of the European Union,
1758 Brussels (BE), 3 December 2001. URL <http://data.europa.eu/eli/dir/2001/95/oj>. OJ L 11 of 15.1.2002.
- 1759 EP and Council, 'Machinery, and amending Directive 95/16/EC', Directive 2006/42/EC, Publications Office of the
1760 European Union, Brussels (BE), 17 May 2006. URL <http://data.europa.eu/eli/dir/2006/42/oj>. OJ L 157
1761 of 9.6.2006.
- 1762 EP and Council, 'Harmonisation of the laws of the Member States relating to electromagnetic compatibility',
1763 Directive 2014/30/EU, Publications Office of the European Union, Brussels (BE), 26 February 2014a. URL
1764 <http://data.europa.eu/eli/dir/2014/30/oj>. OJ L 96 of 29.3.2014.
- 1765 EP and Council, 'Harmonisation of the laws of the Member States relating to equipment and protective systems
1766 intended for use in potentially explosive atmospheres', Directive 2014/34/EU, Publications Office of the European
1767 Union, Brussels (BE), 26 February 2014b. URL <http://data.europa.eu/eli/dir/2014/34/oj>. OJ L 96 of
1768 29.3.2014.
- 1769 EP and Council, 'Harmonisation of the laws of the Member States relating to the making available on the market of
1770 electrical equipment designed for use within certain voltage limits', Directive 2014/35/EU, Publications Office of
1771 the European Union, Brussels (BE), 26 February 2014c. URL <http://data.europa.eu/eli/dir/2014/35/oj>.
1772 OJ L 96 of 29.3.2014.
- 1773 EP and Council, 'Harmonisation of the laws of the Member States relating to the making available on the market
1774 of pressure equipment', Directive 2014/68/EU, Publications Office of the European Union, Brussels (BE), 15 May
1775 2014d. URL <http://data.europa.eu/eli/dir/2014/68/oj>. OJ L 189 of 27.6.2014.
- 1776 IEC, 'Possible safety and health hazards in the use of alkaline secondary cells and batteries - Guide to equipment
1777 manufacturers and users', Technical Report IEC TR 61438:1996, International Electrotechnical Commission,
1778 Geneva (CH), 1996. URL <https://webstore.iec.ch/publication/5455>.
- 1779 IEC, 'Guide for the statistical analysis of ageing test data - Part 2: Validation of procedures for statistical analysis
1780 of censored normally distributed data', Technical Report IEC TR 60493-2:2010, International Electrotechnical
1781 Commission, Geneva (CH), 2010. URL <https://webstore.iec.ch/publication/2260>.
- 1782 IEC, 'Guide for the statistical analysis of ageing test data - Part 1: Methods based on mean values of normally
1783 distributed test results', International Standard IEC 60493-1:2011, International Electrotechnical Commission,
1784 Geneva (CH), 2011. URL <https://webstore.iec.ch/publication/2259>.
- 1785 IEC, 'Explosive atmospheres - Part 17: Electrical installations inspection and maintenance', International Standard
1786 IEC 60079-17:2013, International Electrotechnical Commission, Geneva (CH), 2013. URL [https://webstore.
1787 iec.ch/publication/631](https://webstore.iec.ch/publication/631).
- 1788 IEC, 'Explosive atmospheres - Part 14: Electrical installations design, selection and erection', International
1789 Standard IEC 60079-14:2013, International Electrotechnical Commission, Geneva (CH), 2014a. URL [https://webstore.
1790 //webstore.iec.ch/publication/628](https://webstore.iec.ch/publication/628).
- 1791 IEC, 'Fuel cell technologies - Part 7-2: Test methods - Single cell and stack performance tests for solid oxide fuel
1792 cells (SOFC)', International Standard IEC 62282-7-2:2014, International Electrotechnical Commission, Geneva
1793 (CH), 2014b. URL <https://webstore.iec.ch/publication/6766>.

1794 IEC, 'Safety requirements for electrical equipment for measurement, control, and laboratory use - Part 1: Gen-
1795 eral requirements', International Standard IEC 61010-1:2010+AMD1:2016 CSV, International Electrotechnical
1796 Commission, Geneva (CH), 2016. URL <https://webstore.iec.ch/publication/59769>.

1797 IEC, 'Explosive atmospheres - Part 0: Equipment - General requirements', International Standard IEC 60079-
1798 0:2017, International Electrotechnical Commission, Geneva (CH), 2017a. URL <https://webstore.iec.ch/publication/32878>.

1800 IEC, 'Guidelines for the statistical analysis of ageing test data - Part 3: Minimum specimen numbers at different
1801 test conditions with given experimental data', Technical Report IEC TR 60493-3:2017, International Electrotech-
1802 nical Commission, Geneva (CH), 2017b. URL <https://webstore.iec.ch/publication/27934>.

1803 IEC, 'Safety of machinery - Electrical equipment of machines - Part 11: Requirements for equipment for
1804 voltages above 1 000 V AC or 1 500 V DC and not exceeding 36 kV', International Standard IEC 60204-
1805 11:2018 RLV, International Electrotechnical Commission, Geneva (CH), 2018. URL <https://webstore.iec.ch/publication/63667>.

1807 IEC, 'Fuel cell technologies - Part 3-100: Stationary fuel cell power systems - Safety', International Standard IEC
1808 62282-3-100:2019, International Electrotechnical Commission, Geneva (CH), 2019a. URL <https://webstore.iec.ch/publication/59780>.

1810 IEC, 'Fuel cell technologies - Part 8-102: Energy storage systems using fuel cell modules in reverse mode - Test
1811 procedures for the performance of single cells and stacks with proton exchange membrane, including reversible
1812 operation', International Standard IEC 62282-8-102:2019, International Electrotechnical Commission, Geneva
1813 (CH), 2019b. URL <https://webstore.iec.ch/publication/30534>.

1814 IEC, 'Explosive atmospheres - Part 10-1: Classification of areas - Explosive gas atmospheres', International
1815 Standard IEC 60079-10-1:2020, International Electrotechnical Commission, Geneva (CH), 2020a. URL <https://webstore.iec.ch/publication/63327>.

1817 IEC, 'Fuel cell technologies - Part 2-100: Fuel cell modules - Safety', International Standard IEC 62282-2-
1818 100:2020, International Electrotechnical Commission, Geneva (CH), 2020b. URL <https://webstore.iec.ch/publication/59780>.

1820 IEC, 'Fuel cell technologies - Part 8-101: Energy storage systems using fuel cell modules in reverse mode
1821 - Test procedures for the performance of solid oxide single cells and stacks, including reversible operation',
1822 International Standard IEC 62282-8-101:2020, International Electrotechnical Commission, Geneva (CH), 2020c.
1823 URL <https://webstore.iec.ch/publication/33278>.

1824 IEC, 'Fuel cell technologies - Part 8-201: Energy storage systems using fuel cell modules in reverse mode
1825 - Test procedures for the performance of power-to-power systems', International Standard IEC 62282-8-
1826 201:2020, International Electrotechnical Commission, Geneva (CH), 2020d. URL <https://webstore.iec.ch/publication/31519>.

1828 IEC, 'Safety of machinery - Electrical equipment of machines - Part 1: General requirements', International
1829 Standard IEC 60204-1:2016+AMD1:2021 CSV, International Electrotechnical Commission, Geneva (CH), 2021a.
1830 URL <https://webstore.iec.ch/publication/71256>.

1831 IEC, 'Safety of machinery - Electrical equipment of machines - Part 1: General requirements', International
1832 Standard IEC 60204-1:2016+AMD1:2021 CSV, International Electrotechnical Commission, Geneva (CH), 2021b.
1833 URL <https://webstore.iec.ch/publication/71256>.

1834 IEC, 'Amendment 1 - Fuel cell technologies - Part 3-201: Stationary fuel cell power systems - Performance test
1835 methods for small fuel cell power systems', International Standard IEC 62282-3-201:2017+AMD1:2022 CSV, In-
1836 ternational Electrotechnical Commission, Geneva (CH), 2022. URL <https://webstore.iec.ch/publication/65282>.

1838 ISO, 'Water quality - Determination of calcium content - EDTA titrimetric method', International standard ISO
1839 6058:1984, International Organization for Standardization, Geneva (CH), 1984a. URL <https://www.iso.org/standard/12257.html>.

1841 ISO, 'Water quality - Determination of the sum of calcium and magnesium - EDTA titrimetric method', International
1842 standard ISO 6059:1984, International Organization for Standardization, Geneva (CH), 1984b. URL <https://www.iso.org/standard/12258.html>.

1843

1844 ISO, 'Water quality - Determination of electrical conductivity', International Standard ISO 7888:1985, International Organization for Standardization, Geneva (CH), 1985. URL <https://www.iso.org/standard/14838.html>.

1847 ISO, 'Water quality - Determination of calcium and magnesium - Atomic absorption spectrometric method', International standard ISO 7980:1986, International Organization for Standardization, Geneva (CH), 1986a. URL <https://www.iso.org/standard/14972.html>.

1850 ISO, 'Water quality - Determination of cobalt, nickel, copper, zinc, cadmium and lead - Flame atomic absorption spectrometric methods', International standard ISO 8288:1986, International Organization for Standardization, Geneva (CH), 1986b. URL <https://www.iso.org/standard/15408.html>.

1853 ISO, 'Water for analytical laboratory use - Specification and test methods', International standard ISO 3696:1987, International Organization for Standardization, Geneva (CH), 1987. URL <https://www.iso.org/standard/9169.html>.

1856 ISO, 'Water quality - Determination of iron - Spectrometric method using 1,10-phenanthroline', International standard ISO 6332:1988, International Organization for Standardization, Geneva (CH), 1988. URL <https://www.iso.org/standard/12630.html>.

1859 ISO, 'Water quality - Determination of chloride - Silver nitrate titration with chromate indicator (Mohr's method)', International standard ISO 9297:1989, International Organization for Standardization, Geneva (CH), 1989. URL <https://www.iso.org/standard/16952.html>.

1862 ISO, 'Water quality - Determination of fluoride - Part 1: Electrochemical probe method for potable and lightly polluted water', International standard ISO 10359-1:1992, International Organization for Standardization, Geneva (CH), 1992. URL <https://www.iso.org/standard/18416.html>.

1865 ISO, 'Water quality - Determination of sodium and potassium - Part 1: Determination of sodium by atomic absorption spectrometry', International standard ISO 9964-1:1993, International Organization for Standardization, Geneva (CH), 1993a. URL <https://www.iso.org/standard/17869.html>.

1868 ISO, 'Water quality - Determination of sodium and potassium - Part 2: Determination of potassium by atomic absorption spectrometry', International standard ISO 9964-2:1993, International Organization for Standardization, Geneva (CH), 1993b. URL <https://www.iso.org/standard/17870.html>.

1871 ISO, 'Water quality - Determination of sodium and potassium - Part 3: Determination of sodium and potassium by flame emission spectrometry', International standard ISO 9964-3:1993, International Organization for Standardization, Geneva (CH), 1993c. URL <https://www.iso.org/standard/17871.html>.

1874 ISO, 'Water quality - Determination of fluoride - Part 2: Determination of inorganically bound total fluoride after digestion and distillation', International standard ISO 10359-2:1994, International Organization for Standardization, Geneva (CH), 1994. URL <https://www.iso.org/standard/18417.html>.

1877 ISO, 'Water quality — Determination of dissolved anions by liquid chromatography of ions — Part 4: Determination of chlorate, chloride and chlorite in water with low contamination', International Standard ISO 10304-4:1997, International Organization for Standardization, Geneva (CH), 1997. URL <https://www.iso.org/standard/22573.html>.

1881 ISO, 'Water quality - Determination of dissolved Li⁺, Na⁺, NH₄⁺, K⁺, Mn²⁺, Ca²⁺, Mg²⁺, Sr²⁺ and Ba²⁺ using ion chromatography - Method for water and waste water', International standard ISO 14911:1998, International Organization for Standardization, Geneva (CH), 1998. URL <https://www.iso.org/standard/25591.html>.

1884 ISO, 'Liquid hydrogen - Land vehicle fuelling system interface', International Standard ISO 13984:1999, International Organization for Standardization, Geneva (CH), 1999. URL <https://www.iso.org/standard/23570.html>.

1887 ISO, 'Water quality — Determination of chloride by flow analysis (CFA and FIA) and photometric or potentiometric detection', International standard ISO 15682:2000, International Organization for Standardization, Geneva (CH), 2000. URL <https://www.iso.org/standard/27984.html>.

1890 ISO, 'Water quality — Determination of 15 Polycyclic aromatic hydrocarbons (PAH) in water by HPLC with fluorescence detection after liquid-liquid extraction', International standard ISO 17993:2002, International Organization for Standardization, Geneva (CH), 2002. URL <https://www.iso.org/standard/31666.html>.

1893 ISO, 'Water quality - Determination of polycyclic aromatic hydrocarbons (PAH) - Part 1: Determination of six PAH
1894 by high-performance thin-layer liquid chromatography with fluorescence detection after liquid-liquid extraction',
1895 International standard ISO 7981-1:2005, International Organization for Standardization, Geneva (CH), 2005a.
1896 URL <https://www.iso.org/standard/33883.html>.

1897 ISO, 'Water quality - Determination of polycyclic aromatic hydrocarbons (PAH) - Part 2: Determination of
1898 six PAH by high-performance liquid chromatography with fluorescence detection after liquid-liquid extraction',
1899 International standard ISO 7981-2:2005, International Organization for Standardization, Geneva (CH), 2005b.
1900 URL <https://www.iso.org/standard/33884.html>.

1901 ISO, 'Water quality - Determination of dissolved anions by liquid chromatography of ions - Part 1: Determination
1902 of bromide, chloride, fluoride, nitrate, nitrite, phosphate and sulfate', International standard ISO 10304-1:2007,
1903 International Organization for Standardization, Geneva (CH), 2007. URL [https://www.iso.org/standard/
1904 46004.html](https://www.iso.org/standard/46004.html).

1905 ISO, 'Water quality - Determination of pH', International Standard ISO 10523:2008, International Organization
1906 for Standardization, Geneva (CH), 2008. URL <https://www.iso.org/standard/51994.html>.

1907 ISO, 'Earth-moving machinery and mobile road construction machinery - Worksite data exchange - Part 1: System
1908 architecture', International Standard ISO 15143-1:2010, International Organization for Standardization, Geneva
1909 (CH), 2010a. URL <https://www.iso.org/standard/37406.html>.

1910 ISO, 'Hydrogen generators using fuel processing technologies - Part 2: Test method for performance', Interna-
1911 tional Standard ISO 16110-2:2010, International Organization for Standardization, Geneva (CH), 2010b. URL
1912 <https://www.iso.org/standard/41046.html>.

1913 ISO, 'Quantitative methods in process improvement - Six Sigma - Part 2: Tools and techniques', Technical
1914 Report ISO 13053-2:2011, International Organization for Standardization, Geneva (CH), 2011a. URL <https://www.iso.org/standard/52902.html>.

1915

1916 ISO, 'Water quality - Determination of 16 polycyclic aromatic hydrocarbons (PAH) in water - Method using
1917 gas chromatography with mass spectrometric detection (GC-MS)', International standard ISO 28540:2011,
1918 International Organization for Standardization, Geneva (CH), 2011b. URL [https://www.iso.org/standard/
1919 44752.html](https://www.iso.org/standard/44752.html).

1920 ISO, 'Water quality - Determination of selected parameters by discrete analysis systems - Part 1: Ammonium,
1921 nitrate, nitrite, chloride, orthophosphate, sulfate and silicate with photometric detection', International standard
1922 ISO 15923-1:2013, International Organization for Standardization, Geneva (CH), 2013. URL [https://www.iso.
1923 org/standard/55559.html](https://www.iso.org/standard/55559.html).

1924 ISO, 'Automation systems and integration Key performance indicators (KPIs) for manufacturing operations man-
1925 agement Part 1: Overview, concepts and terminology', International Standard ISO 22400-1:2014, International
1926 Organization for Standardization, Geneva (CH), 2014. URL <https://www.iso.org/standard/56847.html>.

1927 ISO, 'Basic considerations for the safety of hydrogen systems', Technical Report ISO/TR 15916:2015, International
1928 Organization for Standardization, Geneva (CH), 2015. URL <https://www.iso.org/standard/69212.html>.

1929 ISO, 'Information technology - Data centres - Key performance indicators - Part 3: Renewable energy factor
1930 (REF)', International Standard ISO/IEC 30134-3:2016, International Organization for Standardization, Interna-
1931 tional Electrotechnical Commission, Geneva (CH), 2016a. URL <https://www.iso.org/standard/66127.html>.

1932 ISO, 'Water quality - Determination of fluoride using flow analysis (FIA and CFA) — Part 1: Method using flow
1933 injection analysis (FIA) and spectrometric detection after off-line distillation', Technical Specification ISO/TS
1934 17951-1:2016, International Organization for Standardization, Geneva (CH), 2016b. URL [https://www.iso.
1935 org/standard/71104.html](https://www.iso.org/standard/71104.html).

1936 ISO, 'Energy performance of buildings - Overarching EPB assessment - Part 1: General framework and proced-
1937 ures', International Standard ISO 52000-1:2017, International Organization for Standardization, Geneva (CH),
1938 2017a. URL <https://www.iso.org/standard/65601.html>.

1939 ISO, 'Water quality - Determination of selected parameters by discrete analysis systems - Part 2: Chromium(VI),
1940 fluoride, total alkalinity, total hardness, calcium, magnesium, iron, iron(II), manganese and aluminium with photo-
1941 metric detection', Technical Specification ISO/TS 15923-2:2017, International Organization for Standardization,
1942 Geneva (CH), 2017b. URL <https://www.iso.org/standard/66484.html>.

1943 ISO, 'Occupational health and safety management systems - Requirements with guidance for use', International
1944 Standard ISO 45001:2018, International Organization for Standardization, Geneva (CH), 2018. URL <https://www.iso.org/standard/63787.html>.
1945

1946 ISO, 'Hydrogen generators using water electrolysis - Industrial, commercial, and residential applications', Inter-
1947 national Standard ISO 22734:2019, International Organization for Standardization, Geneva (CH), 2019a. URL
1948 <https://www.iso.org/standard/69212.html>.

1949 ISO, 'Solvents for paints and varnishes - Demineralized water for industrial applications - Specification and test
1950 methods', International standard ISO 23321:2019, International Organization for Standardization, Geneva (CH),
1951 2019b. URL <https://www.iso.org/standard/75230.html>.

1952 ISO, 'Water quality - Determination of Perfluoroalkyl and polyfluoroalkyl substances (PFAS) in water - Method
1953 using solid phase extraction and Liquid chromatography-tandem Mass spectrometry (LC-MS/MS)', International
1954 standard ISO 21675:2019, International Organization for Standardization, Geneva (CH), 2019c. URL <https://www.iso.org/standard/71338.html>.
1955

1956 ISO, 'Corrosion of metals and alloys - Vocabulary', International Standard ISO 8044:2020, International Organ-
1957 ization for Standardization, Geneva (CH), 2020a. URL <https://www.iso.org/standard/71134.html>.

1958 ISO, 'Environmental management - Vocabulary', International Standard ISO 14050:2020, International Organiz-
1959 ation for Standardization, Geneva (CH), 2020b. URL <https://www.iso.org/standard/75300.html>.

1960 ISO, 'Environmental management systems - Guidelines for incorporating material circulation in design and
1961 development', International Standard ISO 14009:2020, International Organization for Standardization, Geneva
1962 (CH), 2020c. URL <https://www.iso.org/standard/43244.html>.

1963 ISO, 'Gaseous hydrogen - Fuelling stations - Part 1: General requirements', International Standard ISO 19880-
1964 1:2020, International Organization for Standardization, Geneva (CH), 2020d. URL <https://www.iso.org/standard/71940.html>.
1965

1966 ISO, 'Information technology - Home Electronic System (HES) application model - Part 3-8: GridWise transactive
1967 energy framework', Technical Report ISO/IEC TR 15067-3-8:2020, International Organization for Standardiza-
1968 tion, International Electrotechnical Commission, Geneva (CH), 2020e. URL <https://www.iso.org/standard/81781.html>.
1969

1970 ISO, 'Guidelines for performance evaluation of treatment technologies for water reuse systems - Part 6: Ion
1971 exchange and electrodialysis', International Standard ISO 20468-6:2021, International Organization for Stand-
1972 ardization, Geneva (CH), 2021a. URL <https://www.iso.org/standard/74908.html>.

1973 ISO, 'Safety of machinery - Relationship with ISO 12100 - Part 5: Implications of artificial intelligence machine
1974 learning', Technical Report ISO/TR 22100-5:2021, International Organization for Standardization, Geneva (CH),
1975 2021b. URL <https://www.iso.org/standard/80778.html>.

1976 ISO, 'Buildings and civil engineering works - Vocabulary - Part 3: Sustainability terms', International Standard
1977 ISO 6707-3:2022, International Organization for Standardization, Geneva (CH), 2022a. URL <https://www.iso.org/standard/80456.html>.
1978

1979 ISO, 'Electronic fee collection — Pre-study on the use of vehicle licence plate information and automatic num-
1980 ber plate recognition (ANPR) technologies', Technical Report ISO/TR 6026:2022, International Organization for
1981 Standardization, Geneva (CH), 2022b. URL <https://www.iso.org/standard/81956.html>.

1982 ISO, 'Water quality - Determination of dissolved anions by liquid chromatography of ions - Part 4: Determination
1983 of chlorate, chloride and chlorite in water with low contamination', International standard ISO 10304-4:2022,
1984 International Organization for Standardization, Geneva (CH), 2022c. URL <https://www.iso.org/standard/81538.html>.
1985

1986 ISO and IEC, 'Energy efficiency and renewable energy sources - Common international terminology - Part 1:
1987 Energy efficiency', International Standard ISO/IEC 13273-1:2015, International Organization for Standardiza-
1988 tion, International Electrotechnical Commission, Geneva (CH), 2015a. URL <https://www.iso.org/standard/62606.html>.
1989

1990 ISO and IEC, 'Energy efficiency and renewable energy sources - Common international terminology - Part
1991 2: Renewable energy sources', International Standard ISO/IEC 13273-2:2015, International Organization for
1992 Standardization, International Electrotechnical Commission, Geneva (CH), 2015b. URL <https://www.iso.org/standard/62607.html>.
1993

- 1994 ISO and IEC, 'Information technology - Security techniques - Information security controls for the energy utility industry', International Standard ISO/IEC 27019:2017, International Organization for Standardization, International
1995 Electrotechnical Commission, Geneva (CH), 2017. URL <https://www.iso.org/standard/68091.html>.
1996
- 1997 ISO and IEC, 'Principles and rules for the structure and drafting of ISO and IEC documents', ISO/IEC Directives,
1998 Part 2, Ninth edition, International Organization for Standardization, International Electrotechnical Commission,
1999 Geneva (CH), 2021. URL <https://www.iso.org/sites/directives/current/part2/index.xhtml>.
- 2000 ISO, IEC and IEEE, 'Systems and software engineering - Requirements for testers and reviewers of information
2001 for users', International Standard ISO/IEC/IEEE 26513:2017, International Organization for Standardization,
2002 International Electrotechnical Commission, Institute of Electrical and Electronics Engineers, Geneva (CH), 2017.
2003 URL <https://www.iso.org/standard/67417.html>.
- 2004 Kibsgaard, J. and Chorkendorff, I., 'Considerations for the scaling-up of water splitting catalysts', *Nature Energy*,
2005 Vol. 4, 2019, pp. 430–433. doi:10.1038/s41560-019-0407-1.
- 2006 Chen, C., Tse, Y.-L. S., Lindberg, G. E., Knight, C. and Voth, G. A., 'Hydroxide solvation and transport in anion
2007 exchange membranes', *Journal American Chemical Society*, Vol. 138, No 3, 2016, pp. 991–1000. doi:10.1021/
2008 jacs.5b11951.
- 2009 Dong, D., Zhang, W., van Duin, A. C. T. and Bedrov, D., 'Grotthuss versus vehicular transport of hydroxide in
2010 anion-exchange membranes: Insight from combined reactive and nonreactive molecular simulations', *Journal
2011 of Physical Chemistry Letters*, Vol. 9, No 4, 2018, pp. 825–829. doi:10.1021/acs.jpcclett.8b00004.
- 2012 Carmo, M., Fritz, D. L., Mergel, J. and Stolten, D., 'A comprehensive review on PEM water electrolysis', *International
2013 Journal of Hydrogen Energy*, Vol. 38, No 12, 2013, pp. 4901–4934. ISSN 0360-3199. doi:10.1016/j.ijhydene.
2014 2013.01.151.
- 2015 Chen, M., Chou, S.-F., Blaabjerg, F. and Davari, P., 'Overview of power electronic converter topologies enabling
2016 large-scale hydrogen production via water electrolysis', *Applied Sciences*, Vol. 12, No 4, 2022, p. 1906. doi:
2017 10.3390/app12041906.
- 2018 Alia, S. M., Stariha, S. and Borup, R. L., 'Electrolyzer durability at low catalyst loading and with dynamic operation',
2019 *Journal of the Electrochemical Society*, Vol. 116, No 15, 2019, pp. F1164–F1172. doi:10.1149/2.0231915jes.
- 2020 Ma, Z., Witteman, L., Wrubel, J. A. and Bender, G., 'A comprehensive modeling method for proton exchange
2021 membrane electrolyzer development', *International Journal of Hydrogen Energy*, Vol. 46, No 34, 2021, pp.
2022 17627–17643. doi:10.1016/j.ijhydene.2021.02.170.
- 2023 Hernández-Gómez, Á., Ramirez, V. and Guilbert, D., 'Investigation of pem electrolyzer modeling: Electrical domain,
2024 efficiency, and specific energy consumption', *International Journal of Hydrogen Energy*, Vol. 45, No 29, 2020, pp.
2025 14625–14639. doi:10.1016/j.ijhydene.2020.03.195.
- 2026 Haleem, A. A., Nagasawa, K., Kuroda, Y., Nishiki, Y., Zaenal, A. and Mitsushima, S., 'A new accelerated durability
2027 test protocol for water oxidation electrocatalysts of renewable energy powered alkaline water electrolyzers',
2028 *Electrochemistry*, Vol. 89, No 2, 2021, pp. 186–191. doi:10.5796/electrochemistry.20-00156.
- 2029 Mennemann, C., Haag, S., Borgardt, E., Rost, U., Neumann, J. and Roth, J., 'Defin-
2030 ition of test plan of electrolyser only and coupled system', PROMETH2 Deliverable D5.2,
2031 AIR LIQUIDE Forschung und Entwicklung GmbH, iGas Energy GmbH, ProPuls GmbH, Westfäl-
2032 ische Hochschule, 29 September 2021. URL [https://promet-h2.eu/wp-content/uploads/
2033 definition-of-test-plan-of-electrolyser-only-and-coupled-system.pdf](https://promet-h2.eu/wp-content/uploads/definition-of-test-plan-of-electrolyser-only-and-coupled-system.pdf).
- 2034 Alexander, C. L., Tribollet, B. and Orazem, M. E., 'Influence of micrometric-scale electrode heterogeneity on
2035 electrochemical impedance spectroscopy', *Electrochimica Acta*, Vol. 201, 2016, pp. 374–379. doi:10.1016/j.
2036 electacta.2016.02.133.
- 2037 Falcão, D. S. and Pinto, A. M. F. R., 'A review on PEM electrolyzer modelling: Guidelines for beginners', *Journal of
2038 Cleaner Production*, Vol. 261, 2020, p. 121184. doi:10.1016/j.jclepro.2020.121184.
- 2039 Ausfelder, F., Beilmann, C., Bertau, M., Bräuninger, S., Heinzl, A., Hoer, R., Koch, W., Mahlendorf, F., Metzethin, A.,
2040 Peuckert, M., Plass, L., Räuchle, K., Reuter, M., Schaub, G., Schiebahn, S., Schwab, E., Schüth, F., Stolten, D., Teßmer,
2041 G., Wagemann, K. and Ziegahn, K.-F., 'Energy storage as part of a secure energy supply', *ChemBioEng Reviews*,
2042 Vol. 4, No 3, 2017, pp. 144–210. doi:10.1002/cben.201700004.
- 2043 Fouda-Onana, F., 'AEM WE testing protocols', NEWELY Deliverable D5.1, Commissariat à l'énergie atomique et
2044 aux énergies alternatives, 01 July 2020. URL <https://cordis.europa.eu/project/id/875118/results>.

- 2045 Tsotridis, G. and Pilenga, A., 'EU harmonised terminology for low temperature water electrolysis for energy
2046 storage applications', JRC112082, EUR 29300 EN, KJ-NA-29300-EN-N. Publications Office of the European
2047 Union, Luxembourg (L), 2018. ISBN 978-92-79-90387-8. doi:10.2760/138987. URL <http://publications.jrc.ec.europa.eu/repository/handle/JRC112082>.
- 2049 Tsotridis, G. and Pilenga, A., 'EU harmonised protocols for testing of low temperature water electrolyzers',
2050 JRC122565, EUR 30752 EN, KJ-NA-30752-EN-N. Publications Office of the European Union, Luxembourg (L),
2051 2021. ISBN 978-92-76-39266-8. doi:10.2760/58880. URL <https://publications.jrc.ec.europa.eu/repository/handle/JRC122565>.
- 2053 Sdanghi, G., Maranzana, G., Celzard, A. and Fierro, V., 'Towards non-mechanical hybrid hydrogen compression for
2054 decentralized hydrogen facilities', *energies*, Vol. 13, 2020, p. 3145. doi:10.3390/en13123145.
- 2055 Sayed-Ahmed, H., Árpád Istvan Toldy and Santasalo-Aarnio, A., 'Dynamic operation of proton exchange membrane
2056 electrolyzers - critical review', *Renewable and Sustainable Energy Review*, Vol. 189, 2024, p. 113883. doi:
2057 10.1016/j.rser.2023.113883.
- 2058 Brauns, J. and Turek, T., 'Alkaline water electrolysis powered by renewable energy: A review', *processes*, Vol. 8,
2059 2020, p. 248. doi:10.3390/pr8020248.
- 2060 Chatenet, M., Pollet, B. G., Dekel, D. R., Dionigi, F., Deseure, J., Millet, P., Braatz, R. D., Bazant, M. Z., Eikerling, M.,
2061 Staffell, I., Balcombe, P., Shao-Horn, Y. and Schäfer, H., 'Water electrolysis: from textbook knowledge to the latest
2062 scientific strategies and industrial developments', *Chemical Society Reviews*, Vol. 51, 2022, pp. 4583–4762.
2063 doi:10.1039/DOCS01079K.
- 2064 Bernt, M. P., *Analysis of Voltage Losses and Degradation Phenomena in PEM Water Electrolyzers*. Dissertation,
2065 Technische Universität München, 2019. URL <https://d-nb.info/1185637885/34>.
- 2066 Tahan, M.-R., 'Recent advances in hydrogen compressors for use in large-scale renewable energy integration',
2067 *International Journal of Hydrogen Energy*, Vol. 47, No 83, 2022, pp. 35275–35292. doi:10.1016/j.ijhydene.2022.
2068 08.128.
- 2069 Chowdhury, N. R. and Kant, R., 'Theory of generalized Gerischer impedance for quasi-reversible charge transfer
2070 at rough and finite fractal electrodes', *Electrochimica Acta*, Vol. 281, 2018, pp. 445–458. doi:10.1016/j.electacta.
2071 2018.05.140.
- 2072 Kiemel, S., Smolinka, T., Lehner, F., Full, J., Sauer, A. and Mieke, R., 'Critical materials for water electrolyzers at
2073 the example of the energy transition in Germany', *International Journal of Energy Research*, Vol. 45, 2 2021, p.
2074 9914–9935. doi:10.1002/er.6487.
- 2075 Jha, S. K., Bilalovic, J., Jha, A., Patel, N. and Zhang, H., 'Renewable energy: Present research and future scope of
2076 artificial intelligence', *Renewable and Sustainable Energy Review*, Vol. 77, 2017, pp. 297–317. ISSN 1364-0321.
2077 doi:10.1016/j.rser.2017.04.018.
- 2078 Durmuş, G. N. B., Özgür Çolpan, C. and Devrim, Y., 'A review on the development of the electrochemical hydrogen
2079 compressors', *Journal of Power Sources*, Vol. 494, 2021, p. 229743. doi:10.1016/j.jpowsour.2021.229743.
- 2080 Córdoba-Torres, P., 'Relationship between constant-phase element (CPE) parameters and physical properties of
2081 films with a distributed resistivity', *Electrochimica Acta*, Vol. 225, No 592-604, 2017. doi:10.1016/j.electacta.
2082 2016.12.087.
- 2083 Aßmann, P., Gago, A. S., Gazdzicki, P., Friedrich, K. A. and Wark, M., 'Toward developing accelerated stress tests
2084 for proton exchange membrane electrolyzers', *Current Opinion in Electrochemistry*, Vol. 21, 2020, pp. 225–233.
2085 doi:10.1016/j.coelec.2020.02.024.
- 2086 Flick, S., Dhanushkodi, S. R. and Mérida, W., 'Transport phenomena in polymer electrolyte membrane fuel cells via
2087 voltage loss breakdown', *Journal of Power Sources*, Vol. 280, 2015, pp. 97–106. doi:10.1016/j.jpowsour.2015.
2088 01.099.
- 2089 Stiber, S., Garcia Sanchez, D., Meital, S., Siracusano, S. and Gago, A., '1st document of available testing protocols
2090 for electrolyzers: additional needs and needs for PROMET', PROMETH2 Deliverable D3.2, Deutsches Zentrum für
2091 Luft- und Raumfahrt e.V., Consiglio Nazionale delle Ricerche, Forschungszentrum Jülich GmbH, 30 November
2092 2020. URL <https://cordis.europa.eu/project/id/862253/results>.

- 2093 Lickert, T., Fischer, S., Young, J. L., Klose, S., Franzetti, I., Hahn, D., Kang, Z., Shviro, M., Scheepers, F., Carmo,
2094 M., Smolinka, T., Bender, G. and Metz, S., 'Advances in benchmarking and round robin testing for PEM water
2095 electrolysis: Reference protocol and hardware', *Applied Energy*, Vol. 352, 2023, p. 121898. doi:10.1016/j.
2096 apenergy.2023.121898.
- 2097 Malkow, K. T., Pilenga, A. and Blagoeva, D., 'EU harmonised terminology for hydrogen generated by electrolysis',
2098 EUR 30324 EN, KJ-NA-30324-EN-N. Publications Office of the European Union, Luxembourg (L), 2021. ISBN
2099 978-92-76-21042-9. doi:10.2760/732809. URL [https://publications.jrc.ec.europa.eu/repository/
2100 handle/JRC120120](https://publications.jrc.ec.europa.eu/repository/handle/JRC120120).
- 2101 Malkow, T. and Pilenga, A., 'EU harmonised testing procedure: Determination of water electrolyser en-
2102 ergy performance', JRC Validated Methods, Reference Methods and Measurements Report KJ-07-22-323-
2103 EN-N, Publications Office of the European Union, Luxembourg (L), 2023a. doi:10.2760/922894. URL
2104 <https://publications.jrc.ec.europa.eu/repository/handle/JRC128292>.
- 2105 Malkow, T. and Pilenga, A., 'EU harmonised testing protocols for high-temperature steam electrolysis', JRC
2106 Validated Methods, Reference Methods and Measurements Report KJ-03-22-290-EN-N, Publications Office
2107 of the European Union, Luxembourg (L), 2023b. doi:10.2760/7940. URL [https://publications.jrc.ec.
2108 europa.eu/repository/handle/JRC129387](https://publications.jrc.ec.europa.eu/repository/handle/JRC129387).
- 2109 Malkow, T., Pilenga, A. and Tsotridis, G., 'EU harmonised test procedure: electrochemical impedance spectroscopy
2110 for water electrolysis cells', JRC Validated Methods, Reference Methods and Measurements Report KJ-NA-
2111 29267-EN-N, European Commission, Luxembourg (Luxembourg), 2018a. doi:10.2760/8984. URL [https://
2112 publications.jrc.ec.europa.eu/repository/handle/JRC107053](https://publications.jrc.ec.europa.eu/repository/handle/JRC107053).
- 2113 Malkow, T., Pilenga, A., Tsotridis, G. and De Marco, G., 'EU harmonised polarisation curve test method for
2114 low-temperature water electrolysis', JRC Validated Methods, Reference Methods and Measurements Report
2115 KJ-NA-29182-EN-N, European Commission, Luxembourg (Luxembourg), 2018b. doi:10.2760/179509. URL
2116 <https://publications.jrc.ec.europa.eu/repository/handle/JRC104045>.
- 2117 Boukamp, B. A., 'A nonlinear least squares fit procedure for analysis of immittance data of electrochemical
2118 systems', *Solid State Ionics*, Vol. 20, No 1, 1986, pp. 31–44. doi:10.1016/0167-2738(86)90031-7.
- 2119 Boukamp, B. A., 'Electrochemical impedance spectroscopy in solid state ionics: recent advances', *Solid State
2120 Ionics*, Vol. 169, No 1, 2004, pp. 65–73. doi:10.1016/j.ssi.2003.07.002. Proceedings of the Annual Meeting of
2121 International Society of Electrochemistry.
- 2122 Boukamp, B. A., 'Derivation of a distribution function of relaxation times for the (fractal) finite length Warburg',
2123 *Electrochimica Acta*, Vol. 252, 2017, pp. 154–163. doi:10.1016/j.electacta.2017.08.154.
- 2124 Boukamp, B. A., 'Distribution (function) of relaxation times, successor to complex nonlinear least squares analysis
2125 of electrochemical impedance spectroscopy?', *Journal of Physics: Energy*, Vol. 2, No 4, 2020, p. 042001. doi:
2126 10.1088/2515-7655/aba9e0. URL <https://dx.doi.org/10.1088/2515-7655/aba9e0>.
- 2127 Miller, H. A., Bouzek, K., Hnat, J., Loos, S., Bernäcker, C. I., Weißgärber, T., Röntzsch, L. and Meier-Haack, J.,
2128 'Green hydrogen from anion exchange membrane water electrolysis: a review of recent developments in
2129 critical materials and operating conditions', *Sustainable Energy Fuels*, Vol. 4, 2020, pp. 2114–2133. doi:
2130 10.1039/C9SE01240K.
- 2131 Aricò, A. S., Carbone, A., Zignani, S., Monforte, G., Minutoli, M., Girolamo, M., Patti, A., Bottari, M., Jones, D.,
2132 Cavaliere, S., Dupont, M., Rozière, J., Tal-Gutelmacher, E., Amel, A., Jones, S., Wright, J., van Dijk, N., Grahl-
2133 Madsen, L., Odgaard, M., Schutyser, W. and Knauf, S., 'Harmonised test protocols for assessing AEM electrolysis
2134 components, cells and stacks in a wide range of operating temperature and pressure', ANIONE Deliverable D2.1,
2135 Consiglio Nazionale delle Ricerche, Centre national de la recherche scientifique, Pocelltech, PV3 Technologies
2136 Ltd, IRD Fuel Cells A/S, Hydrogenics Europe NV, 24 June July 2020. URL [https://anione.eu/wp-content/
2137 uploads/2020/07/D2.1-%E2%80%93Harmonised-test-protocols.pdf](https://anione.eu/wp-content/uploads/2020/07/D2.1-%E2%80%93Harmonised-test-protocols.pdf).
- 2138 Aricò, A. S., Briguglio, N., Siracusano, S., Baglio, V., Lister, R., Greenhalgh, D., Yeomans, K., Yu, H., van Dijk, N.,
2139 Bonelli, R., Subinas, J., Dupont, M., Bourgogne, D., Merlo, L., Moukheiber, E., Tsotridis, G., Malkow, T. and Pilenga, A.,
2140 'Protocols for Stack and System Characterisation', ELECTROHYPEM Deliverable D2.2, Consiglio Nazionale delle
2141 Ricerche, ITM Power plc, TRE SpA TOZZI Renewable Energy, Centre national de la recherche scientifique, Solvay
2142 Speciality Polymers Italy SpA, Joint Research Centre, 09 August 2013. URL [https://www.electrohypep.eu/
2143 data/D2-2_PROTOCOLS-FOR-STACK-AND-SYSTEM-CHARACTERISATION.pdf](https://www.electrohypep.eu/data/D2-2_PROTOCOLS-FOR-STACK-AND-SYSTEM-CHARACTERISATION.pdf).

- 2144 Aricò, A. S., Siracusano, S., Briguglio, N., Baglio, V., Van Dijk, N., Yildirim, H., Greenhalgh, D., Merlo, L., Tonella, S.,
2145 Grahl-Madsen, L., Kielmann, G. and Steinigeweg, S., 'Protocols for characterisation of system components and
2146 electrolysis system assessment', HPEM2GAS Deliverable D2.1, Consiglio Nazionale delle Ricerche - Istituto di
2147 Tecnologie Avanzate per l'Energia "Nicola Giordano", ITM Power (Trading) Limited, Solvay speciality Polymers
2148 Italy SpA, IRD Fuel Cells A/S, Stadtwerke Emden GmbH, Hochschule Emden/Leer, 30 September 2016. URL
2149 <https://cordis.europa.eu/project/id/700008/results>.
- 2150 Aricò, A. S., Siracusano, S., Briguglio, N., Trocino, S., Baglio, V., Greenhalgh, D., Hody, S., Oldani, C., Tonella, S.,
2151 Infantino, M. and Grahl-Madsen, L., 'Harmonised test protocols for assessing system components, stack and
2152 balance of plant in a wide range of operating temperature and pressures', NEPTUNE Deliverable D2.1, Consiglio
2153 Nazionale delle Ricerche, ITM Power plc, Engie, Solvay Speciality Polymers Italy SpA, EWII Fuel Cells A/S, 12 July
2154 2018. URL <https://cordis.europa.eu/project/id/779540/results>.
- 2155 Siracusano, S., Trocino, S., Briguglio, N., Baglio, V. and Aricò, A. S., 'Electrochemical impedance spectroscopy
2156 as a diagnostic tool in polymer electrolyte membrane electrolysis', *materials*, Vol. 11, No 8, 2018, p. 1368.
2157 doi:10.3390/ma11081368.
- 2158 ITM Power plc, 'Next Generation PEM Electrolyser under New Extremes', Project information, CORDIS, 2018.
2159 doi:10.3030/779540. URL <https://cordis.europa.eu/project/id/779540>.
- 2160 Khan, M. A., Al-Attas, T., Roy, S., Rahman, M. M., Ghaffour, N., Thangadurai, V., Larter, S., Hu, J., Ajayan, P. M.
2161 and Kibria, M. G., 'Seawater electrolysis for hydrogen production: a solution looking for a problem?', *Energy &*
2162 *Environmental Science*, Vol. 14, 2021, pp. 4831–4839. doi:10.1039/D1EE00870F.
- 2163 Malkow, K. T., 'One year time series of relative electric photovoltaic power dataset'. September 2023a. doi:
2164 10.5281/zenodo.8316473. URL <https://doi.org/10.5281/zenodo.8316473>.
- 2165 Malkow, K. T., 'One year time series of relative electric (onshore and offshore) wind turbine power datasets'.
2166 September 2023b. doi:10.5281/zenodo.8316692. URL <https://doi.org/10.5281/zenodo.8316692>.
- 2167 Malkow, T., 'Complex valued DRT explained - DRT estimation by deconvolution of EIS data'. 2021. doi:10.5281/
2168 zenodo.5718121. URL <https://doi.org/10.5281/zenodo.5718121>.
- 2169 Marciuš, D., Kovač, A. and Firak, M., 'Electrochemical hydrogen compressor: Recent progress and challenges',
2170 *International Journal of Hydrogen Energy*, Vol. 47, No 57, 2022, pp. 24179–24193. doi:10.1016/j.ijhydene.2022.
2171 04.134.
- 2172 Mayerhöfer, B., McLaughlin, D., Böhm, T., Hegelheimer, M., Seeberger, D. and Thiele, S., 'Bipolar membrane
2173 electrode assemblies for water electrolysis', *ACS Applied Energy Materials*, Vol. 3, No 10, 2020, pp. 9635–9644.
2174 doi:10.1021/acsaem.0c01127.
- 2175 Parache, F., Schneider, H., Turpin, C., Richet, N., Debellemanièrè, O., Éric Bru, Thieu, A. T., Bertail, C. and Marot, C.,
2176 'Impact of power converter current ripple on the degradation of pem electrolyzer performances', *membranes*,
2177 Vol. 12, No 2, 2022, p. 109. doi:10.3390/membranes12020109.
- 2178 Santoro, C., Lavacchi, A., Mustarelli, P., Di Noto, V., Elbaz, L., Dekel, D. R. and Jaouen, F., 'What is next in
2179 anion-exchange membrane water electrolyzers? bottlenecks, benefits, and future', *Chemistry-Sustainability-*
2180 *Energy-Materials*, Vol. 15, No 8, 2022, p. e202200027. doi:10.1002/cssc.202200027.
- 2181 Schmucker, M., Gully, T. A., AlexeiSchmidt, Schmidt, B., Bromberger, K., Disch, J., Butschke, B., Burgenmeister,
2182 B., Sonnenberg, K., Riedel, S. and Krossing, I., 'Investigations toward a non-aqueous hybrid redox-flow battery
2183 with a manganese-based anolyte and catholyte', *Advanced Energy Materials*, Vol. 11, No 24, 2021, p. 2101261.
2184 doi:10.1002/aenm.202101261.
- 2185 Strataki, E., 'Compliance test protocols and analytics', PRETZEL Deliverable D2.2, Centre for Research & Techno-
2186 logic, Hellas, 31 August 2018. URL <https://cordis.europa.eu/project/id/779478/results>.
- 2187 Szekeres, K. J., Vesztergom, S., Ujvári, M. and Láng, G. G., 'Methods for the determination of valid imped-
2188 ance spectra in non-stationary electrochemical systems: Concepts and techniques of practical importance',
2189 *ChemElectroChem*, Vol. 8, No 7, 2021, pp. 1233–1250. doi:10.1002/celec.202100093.
- 2190 VERBUND Energy4Business GmbH, 'Hydrogen meeting FUTURE needs of low carbon manufacturing value chains',
2191 Project information, CORDIS, 2017. doi:10.3030/735503. URL <https://cordis.europa.eu/project/id/735503>.
2192

2193 List of Abbreviations and Acronyms

2194	A/S Aktieselskab
2195	AAEMEC alkaline anion exchange polymer membrane electrolysis cell
2196	AAEMWE alkaline anion exchange polymer membrane water electrolyser
2197	AAS atomic absorption spectrometry
2198	AC alternating current
2199	AC/DC AC-to-DC
2200	AEC alkaline water electrolysis cell
2201	AEL alkaline water electrolysis
2202	AEM anion exchange polymer membrane
2203	AEMEC anion exchange polymer membrane water electrolysis cell
2204	AEMEL anion exchange membrane water electrolysis
2205	AEMWE anion exchange polymer membrane water electrolyser
2206	AG Aktiengesellschaft
2207	AI artificial intelligence
2208	ALT accelerated lifetime testing
2209	AMD amendment
2210	ANIONE Anion Exchange Membrane Electrolysis for Renewable Hydrogen Production on a Wide-Scale
2211	ANPR automatic number plate recognition
2212	ARMINES Association pour la Recherche et le Développement des Méthodes et Processus Industriels
2213	AS Aktsiaselts
2214	ASA Allmennaksjeselskap
2215	ASR area-specific resistance
2216	AST accelerated stress testing
2217	ATEX Appareils destinés à être utilisés en atmosphères explosibles
2218	AWE alkaline water electrolyser
2219	AWI approved working item
2220	biP bipolar plate
2221	BoL beginning-of-life
2222	BoP balance of plant
2223	BoT beginning-of-test
2224	BPMEL bipolar polymer membrane water electrolysis
2225	BPMWE bipolar polymer membrane water electrolyser
2226	BPMWEC bipolar polymer membrane water electrolysis cell
2227	BV besloten vennootschap
2228	BVBA Besloten Vennootschap met Beperkte Aansprakelijkheid
2229	CAPEX capital expenditure
2230	CC BY 4.0 Creative Commons Attribution 4.0 International
2231	CEA Commissariat à l'énergie atomique et aux énergies alternatives
2232	CERTH Centre for Research & Technology, Hellas
2233	CFA continuous flow analysis
2234	CGH₂ compressed gaseous hydrogen
2235	CH Switzerland
2236	CL catalyst layer
2237	Clean H₂ JU Clean Hydrogen Joint Undertaking
2238	CNLS complex non-linear least squares
2239	CNR Consiglio Nazionale delle Ricerche
2240	CNRS Centre national de la recherche scientifique
2241	CORDIS Community Research and Development Information Service
2242	CPE constant phase element
2243	CRM critical raw materials
2244	CSIC Consejo Superior de Investigaciones Científicas
2245	CSV consolidated version
2246	DAQ data acquisition
2247	DC direct current
2248	DC/DC DC-to-DC
2249	DER distributed energy resources
2250	DLR Deutsches Zentrum für Luft- und Raumfahrt e. V.
2251	DoE design of experiment
2252	doi digital object identifier

2253 **DRT** distribution of uncorrelated relaxation times

2254 **EC** European Commission

2255 **ECN** Stichting Energieonderzoek Centrum Nederland

2256 **EDTA** ethylenediaminetetraacetic acid

2257 **EEA** European Economic Area

2258 **EEC** equivalent electric circuit

2259 **EESS** electrical energy storage system

2260 **EIS** electrochemical impedance spectroscopy

2261 **ELECTROHYPEM** Enhanced performance and cost-effective materials for long-term operation of PEM water
electrolysers coupled to renewable power sources

2262 **EMC** electromagnetic compatibility

2263 **EN** English

2264 **ENSMP** École nationale supérieure des mines de Paris

2265 **End-of-test**

2266 **ES** energy storage

2267 **EU** European Union

2268 **EUR** European Union Report

2269 **EIEE** Εταιρεία Περιορισμένης Ευθύνης

2270 **FBK** Fondazione Bruno Kessler

2271 **FC** fuel cell

2272 **FCH2JU** Fuel Cells and Hydrogen second Joint Undertaking

2273 **FES** flame emission spectrometry

2274 **FHa** Fundación para el Desarrollo de las Tecnologías del Hidrógeno en Aragón

2275 **FIA** flow injection analysis

2276 **FZJ** Forschungszentrum Jülich GmbH

2277 **GC** gas chromatography

2278 **GDL** gas diffusion layer

2279 **GLP** good laboratory practice

2280 **GmbH** Gesellschaft mit beschränkter Haftung

2281 **GUM** Guide to the expression of uncertainty in measurement

2282 **H2FUTURE** Hydrogen meeting FUTURE needs of low carbon manufacturing value chains

2283 **H₂-to-I** hydrogen-to-industry

2284 **H₂-to-M** hydrogen-to-mobility

2285 **H₂-to-P** hydrogen-to-power

2286 **HER** hydrogen evolution reaction

2287 **HES** Home Electronic System

2288 **HHV** higher heating value

2289 **HPEM2GAS** High Performance PEM Electrolyzer for Cost-effective Grid Balancing Applications

2290 **HPLC** high-performance liquid chromatography

2291 **HPTLC** high-performance thin-layer liquid chromatography

2292 **HRFB** hybrid redox flow battery

2293 **IC** ion chromatography

2294 **ICT** Institut für Chemische Technologie

2295 **IEC** International Electrotechnical Commission

2296 **IEEE** Institute of Electrical and Electronics Engineers

2297 **IEM** ion exchange membrane

2298 **IEV** International Electrotechnical Vocabulary

2299 **ISBN** international standard book number

2300 **ISO** International Organization for Standardization

2301 **ISSN** international standard serial number

2302 **JCGM** Joint Committee for Guides in Metrology

2303 **JRC** Joint Research Centre

2304 **KG** Kommanditgesellschaft

2305 **KIST** Korea Institute of Science and Technology

2306 **KPI** key performance indicator

2307 **L** Luxembourg

2308 **LC** liquid chromatography

2309 **LH₂** liquid hydrogen

2310 **LHV** lower heating value

2311 **LT** low-temperature

2312 **LTWE** low-temperature water electrolyser

2313

2314 **LTWEL** low-temperature water electrolysis

2315 **LV** low-voltage

2316 **LVD** Low-Voltage Directive

2317 **ML** machine learning

2318 **MPL** micro-porous layer

2319 **MS** mass spectrometry

2320 **MV** medium-voltage

2321 **NC** national committee

2322 **NEPTUNE** Next Generation PEM Electrolyser under New Extremes

2323 **NEWELY** Next Generation Alkaline Membrane Water Electrolysers with Improved Components and Materials

2324 **NV** naamloze vennootschap

2325 **OCV** open circuit potential

2326 **OCV** open circuit voltage

2327 **OER** oxygen evolution reaction

2328 **OHS** occupational health and safety

2329 **OJ** Official Journal

2330 **P-to-C** power-to-chemical

2331 **P-to-F** power-to-fuel

2332 **P-to-G** power-to-gas

2333 **P-to-H₂** power-to-hydrogen

2334 **P-to-L** power-to-liquid

2335 **P-to-M** power-to-mobility

2336 **P-to-X** power-to-X

2337 **PAH** polycyclic aromatic hydrocarbons

2338 **PDF** portable document format

2339 **PED** Pressure Equipment Directive

2340 **PEM** proton exchange polymer membrane

2341 **PEMEC** proton exchange polymer membrane water electrolysis cell

2342 **PEMEL** proton exchange membrane water electrolysis

2343 **PEMWE** proton exchange polymer membrane water electrolyser

2344 **PFAS** perfluoroalkyl and polyfluoroalkyl substances

2345 **PFC** per- and polyfluorinated compounds

2346 **PFSA** perfluoro sulfonic acid

2347 **PGM** platinum-group metals

2348 **plc** public limited company

2349 **PoC** point of connection

2350 **PPS** polyphenylene sulfide

2351 **PRETZEL** Novel modular stack design for high pressure PEM water electrolyzer technology with wide operation range and reduced cost

2352 **PROMETH2** Cost-effective PROton Exchange MEmbrane WaTer Electrolyser for Efficient and Sustainable Power-to-H₂ Technology

2353 **PTL** porous transport layer

2354 **PV** photovoltaic

2355 **R&D** research and development

2356 **R&I** research and innovation

2357 **REACH** registration, evaluation, authorisation and restriction of chemicals

2358 **REF** renewable energy factor

2359 **RES** renewable energy source

2360 **RFB** redox flow battery

2361 **RLV** redline version

2362 **RTO** research and technology organisation

2363 **RUL** remaining useful life

2364 **S.L.** Sociedad Limitada

2365 **SA** Société anonyme

2366 **SARL** Société à responsabilité limitée

2367 **SAS** Société par actions simplifiée

2368 **SATP** standard ambient temperature and pressure

2369 **SCADA** supervisory control and data acquisition

2370 **SHE** standard hydrogen electrode

2371 **SI** Système International d'Unités

2372 **SINTEF** Stiftelsen for industriell og teknisk forskning

- 2375 **SoA** state-of-the-art
- 2376 **SpA** Società per azioni
- 2377 **SRIA** strategic research and innovation agenda 2021-2027 of the Clean Hydrogen Partnership for Europe
- 2378 **TC** Technical Committee
- 2379 **TEU** Treaty on European Union
- 2380 **TFEU** Treaty on the Functioning of the European Union
- 2381 **TIP** test input parameter
- 2382 **TNO** Nederlandse Organisatie voor Toegepast Natuurwetenschappelijk Onderzoek
- 2383 **TOP** test output parameter
- 2384 **TR** Technical Report
- 2385 **TRL** technology readiness level
- 2386 **TS** Technical Specification
- 2387 **UG** Unternehmersgesellschaft
- 2388 **URL** uniform resource locator
- 2389 **UV** ultraviolet
- 2390 **VRE** variable renewable energy
- 2391 **VSCHT** Vysoká Škola chemicko-technologická v Praze
- 2392 **WE** water electrolyser
- 2393 **WE system** water electrolyser system
- 2394 **WEC** water electrolysis cell
- 2395 **WEL** water electrolysis
- 2396 **WG** working group
- 2397 **WT** wind turbine

List of Symbols

Notation	Description
(aq)	subscript denoting aqueous phase
(ed)	subscript denoting electrode
(g)	subscript denoting gaseous phase
(l)	subscript denoting liquid phase
$ Y $	modulus of electrical admittance
Z^*	modulus of electrical impedance
A_{act}	active electrode area
$a_{\text{H}_2\text{O}}$	activity of liquid water
α	power exponent
α_{a}	anodic charge transfer coefficient
α_{c}	cathodic charge transfer coefficient
$\arg(Y)$	argument of electrical admittance
$\arg(Z)$	argument of electrical impedance
C	capacitance
C	carbon
$c_{\text{H}_2}^0$	equilibrium hydrogen concentration
$c_{\text{O}_2}^0$	equilibrium oxygen concentration
Ca	calcium
c_{Ca}	calcium concentration
c_{Cl}	chloride concentration
c_{Cu}	copper concentration
$C_{\text{dl,a}}$	anodic double layer capacitance
$C_{\text{dl,c}}$	cathodic double layer capacitance
c_{F}	fluoride concentration
c_{PAH}	PAH concentration
c_{PFAS}	PFAS concentration
c_{Fe}	iron concentration
c_{H_2}	hydrogen concentration
c_{K}	potassium concentration
Cl^-	chloride
c_{Mg}	magnesium concentration
c_{Na}	sodium concentration
c_{Ni}	nickel concentration
Co	cobalt
CO_2	carbon dioxide
c_{O_2}	oxygen concentration
CO_3	carbonate
c_{p}	specific heat capacity at constant pressure
c_{p}^i	specific heat capacity at constant pressure of fluid i
c_{p}^j	specific heat capacity at constant pressure of fluid j
Cu	copper
c_{V}^j	specific heat capacity at constant volume of fluid j
c_{Zn}	zinc concentration
d_{dl}	double layer length
$\Delta_{q_{\text{m,H}_2}}^k E$	total change of energy per unit of mass of hydrogen
$\Delta_{q_{\text{m,H}_2}}^k U$	total change of voltage per unit of hydrogen mass flow rate
$\Delta_{q_{\text{V,H}_2}}^k U$	total change of energy per unit of volume of hydrogen
$\Delta_{q_{\text{V,H}_2}}^k U$	total change of voltage per unit of hydrogen volumetric flow rate
$\Delta_{\text{rel}}^k \eta_{\text{HHV,e}}^0$	relative rate of change of energy efficiency based on HHV under SATP conditions of hydrogen
$\Delta_{\text{rel}}^k \eta_{\text{HHV,el}}^0$	relative rate of change of electrical efficiency based on HHV under SATP conditions of hydrogen
$\Delta_{\text{rel}}^k \eta_{\text{LHV,e}}^0$	relative rate of change of energy efficiency based on LHV under SATP conditions of hydrogen
$\Delta_{\text{rel}}^k \eta_{\text{LHV,el}}^0$	relative rate of change of electrical efficiency based on LHV under SATP conditions of hydrogen

Notation	Description
$\Delta_{\text{rel}}^k \text{MAE} \overline{U_{\text{cell}}}$	relative rate of change of mean absolute error average cell voltage
$\Delta_{\text{rel}}^k P$	relative rate of change of power
$\Delta_{\text{rel}}^k R_{\text{ASR}}$	relative rate of change of area-specific resistance
$\Delta_{\text{rel}}^k R_{\Omega}$	relative rate of change of ohmic resistance
$\Delta_{\text{rel}}^k \text{SD} \overline{U_{\text{cell}}}$	relative rate of change of standard deviation of average cell voltage
$\Delta_{\text{rel}}^k U$	relative rate of change of voltage
$\Delta_{\text{tot}}^k \eta_{\text{HHV,e}}^0$	total rate of change of energy efficiency based on HHV under SATP conditions of hydrogen
$\Delta_{\text{tot}}^k \eta_{\text{HHV,el}}^0$	total rate of change of electrical efficiency based on HHV under SATP conditions of hydrogen
$\Delta_{\text{tot}}^k \eta_{\text{LHV,e}}^0$	total rate of change of energy efficiency based on LHV under SATP conditions of hydrogen
$\Delta_{\text{tot}}^k \eta_{\text{LHV,el}}^0$	total rate of change of electrical efficiency based on LHV under SATP conditions of hydrogen
$\Delta_{\text{tot}}^k \text{MAE} \overline{U_{\text{cell}}}$	total rate of change of mean absolute error average cell voltage
$\Delta_{\text{tot}}^k P$	total rate of change of power
$\Delta_{\text{tot}}^k R_{\text{ASR}}$	total rate of change of area-specific resistance
$\Delta_{\text{tot}}^k R_{\Omega}$	total rate of change of ohmic resistance
$\Delta_{\text{tot}}^k \text{SD} \overline{U_{\text{cell}}}$	total rate of change of standard deviation of average cell voltage
$\Delta_{\text{tot}}^k U$	total rate of change of voltage
E	energy
e^-	electron
E_{compr}	pneumatic energy
E_{el}	electric energy
ε	absolute permittivity
E_{ramp}	ramp energy
U_{rev}	voltage under reversible (equilibrium) conditions
η	efficiency
η_{e}	energy efficiency
$\eta_{\text{HHV,e}}^0$	energy efficiency based on HHV under SATP conditions of hydrogen
η_{el}	electrical efficiency
$\eta_{\text{HHV,el}}^0$	electrical efficiency based on HHV under SATP conditions of hydrogen
$\eta_{\text{LHV,e}}^0$	energy efficiency based on LHV under SATP conditions of hydrogen
$\eta_{\text{LHV,el}}^0$	electrical efficiency based on LHV under SATP conditions of hydrogen
E_{th}	thermal energy
F	Faraday constant
F	fluorine
f	frequency
F^-	fluoride
f_{compr}	compression factor
Fe	iron
f_{max}	maximum frequency
f_{min}	minimum frequency
γ^j	isentropic expansion factor of fluid j
H	hydrogen
H^+	proton
H_2	molecular hydrogen or dihydrogen
H_2O	steam
H_3O^+	hydrated proton
HHV_{H_2}	higher heating value of hydrogen
I	current
i	imaginary unit
$I_{0,\text{a}}$	anodic exchange current
$I_{0,\text{c}}$	cathodic exchange current
I_{a}	anodic current
I_{c}	cathodic current
I_{dc}	direct current

Notation	Description
I_{in}	input current
I_{max}	maximum current
$\Im m Z$	imaginary part of electrical impedance
I_{nom}	nominal (rated) current
Ir	iridium
IrO_x	iridium oxide
I_{stack}	stack current
J	current density
J_{stack}	stack current density
K	potassium
KCl	potassium chloride
KOH	potassium hydroxide
L	inductance
LHV_{H_2}	lower heating value of hydrogen
$MAE \overline{U_{cell}}$	mean absolute error average cell voltage
Mg	magnesium
m_{H_2}	molar mass of hydrogen
Na	sodium
N_{cell}	number of cells
Ni	nickel
O	oxygen
O_2	molecular oxygen or dioxygen
OH^-	hydroxide ion
ω	angular frequency
P	power
p	pressure
p^0	standard ambient pressure
P_{compr}	power of compression
$P_{compr, in}$	input power of compression
P_{el}	electric power
$P_{el, d}$	electric power density
$P_{el, dc}$	DC power
$P_{el, d, stack}$	stack electric power density
$P_{el, in}$	input electric power
$P_{el, nom}$	nominal (rated) electric power
p_{H_2}	pressure of hydrogen
p_{H_2}	partial pressure of hydrogen
p_{H_2}	pressure of hydrogen
pH_{lye}	pH value of lye solution
pH_w	pH value of liquid water
p^j	pressure of fluid j
p_{O_2}	partial pressure of oxygen
P_{stack}	stack power
Pt	platinum
P_{th}	thermal power
$P_{th, in}$	input thermal power
q	flow rate
Q_C	non-ideal capacitance
Q_L	non-ideal inductance
q_m	mass flow rate
q_{m, H_2}	mass flow rate of hydrogen
q_m^i	mass flow rate of fluid i
q_n	molar flow rate
q_{n, H_2}	molar flow rate of hydrogen
q_n^j	molar flow rate of fluid j
q_{n, O_2}	molar flow rate of oxygen
$q_{n, out}$	product gas molar flow rate
q_{V, H_2}^{theo}	theoretical volumetric flow rate of hydrogen
q_{V, H_2}	volumetric flow rate of hydrogen

Notation	Description
R	resistance
R_0	zero-frequency resistance
R_{ASR}	area-specific resistance
$R_{ct, a}$	anodic charge transfer resistance
$R_{ct, c}$	cathodic charge transfer resistance
$\Re Z$	real part of electrical impedance
R_g	universal gas constant
R_{hf}	high-frequency resistance
R_∞	infinite-frequency resistance
R_{lf}	low-frequency resistance
R_Ω	ohmic resistance
R_{pol}	polarisation resistance
RuO_y	ruthenium oxide
$SD \overline{U_{cell}}$	standard deviation of average cell voltage
T	temperature
t	time
T^0	standard ambient temperature
t_0	time at beginning-of-test
$\tan(\Im m Z / \Re Z)$	tangent of loss angle of electrical impedance
t_{compr}	duration of the compressed operation profile
T_{H_2}	temperature of hydrogen
T^i	temperature of fluid i
Ti	titanium
TiO_x	titanium oxide
t_k	time at interval k
T_{in}^{lye}	input temperature of lye
t_{origin}	duration of the original operation profile
t_{resp}	response time
T_{stack}	stack operating temperature
T_w	water temperature
T_{in}^w	input water temperature
U	voltage
u	standard uncertainty
U_{act}	activation polarisation voltage
u_c	combined standard uncertainty
$\overline{U_{cell}}$	cell voltage
$\overline{U_{cell}}$	average cell voltage
$U_{cell, n}$	voltage of cell n
U_{conc}	concentration polarisation voltage
$U_{cut-off}$	cut-off voltage
U_{dc}	DC voltage
U_{in}	input voltage
U_{nom}	nominal (rated) voltage
U_{OCP}	open circuit potential
U_{OCV}	open circuit voltage
U_{rev}	reversible voltage
U_{stack}	stack voltage
U_{tn}	thermal-neutral voltage
U_{WEC}	water electrolysis cell voltage
V	volume
V_{m, H_2}	molar volume of hydrogen
X	reactance
x_{n, H_2}	molar concentration of hydrogen
x_{n, O_2}	molar concentration of oxygen
Y	electrical admittance
Y^*	complex conjugate of electrical admittance
Z	electrical impedance
z	number of electrons exchanged
Z^*	complex conjugate of electrical impedance

Notation	Description
\bar{Z}	average compressibility factor
\bar{Z}^j	average compressibility factor of fluid j
Zn	zinc
σ_{el}	electrical conductivity
$\sigma_{el,lye}$	electrical conductivity of lye solution
$\sigma_{el,w}$	electrical conductivity of liquid water
τ	time constant

2399 **List of Figures**

2400 **Figure 1.1.** Schematic of a WE system 5
2401 **Figure 5.1.** Schematic of the input and output streams of energy forms and substances of an AWE stack . 22
2402 **Figure 5.2.** Schematic of the input and output streams of energy forms and substances of an AEMWE stack 23
2403 **Figure 5.3.** Schematic of the input and output streams of energy forms and substances of a PEMWE stack 24
2404 **Figure 6.1.** Nyquist plot of the electrical impedance of a WEC 34
2405 **Figure 6.2.** Bode plot of the electrical impedance of a WEC 35
2406 **Figure 6.3.** Simplified EEC model of an electrolyser connected to a DC source 37
2407 **Figure 6.4.** Daily PV electric power derived operation profiles 38
2408 **Figure 6.5.** Yearly PV electric power derived operation profile 41
2409 **Figure 6.6.** Daily onshore and offshore WT electric power derived operation profiles 41
2410 **Figure 6.7.** Yearly onshore and offshore WT electric power derived operation profile 46

2411 **List of Tables**

2412 **Table 3.1.** Common advantages, disadvantages and main challenges of three major LTWEL technologies . 11
2413 **Table 6.1.** Recommended reference operating conditions for WE stacks 28
2414 **Table 7.1.** Test output parameter as test results 51

2415 **Annex A Test safety**

2416 In LTWE stacks, hazards arises from

- 2417 • generated hydrogen and oxygen gases,
- 2418 • use of alkaline solution,
- 2419 • temperature,
- 2420 • pressure and
- 2421 • voltage.

2422 During installation, commissioning, operation, quiescence, maintenance and decommissioning, the safety of
2423 persons requires due care and vigilance by all parties. Entities carrying out testing and chemical analysis
2424 should comply with the occupational health and safety (OHS) requirements of ISO 45001:2018 (ISO, 2018)
2425 and good laboratory practice (GLP). Tests on WE stacks shall be conducted in accordance with the applicable
2426 legislation, granted licenses and issued permits not to pose harm or unacceptable risk to humans, property and
2427 the environment.

2428 IEC published guidance on safety of electrical equipment (IEC, 2021b, IEC, 2018) and alkaline ES devices (IEC,
2429 1996). ISO published guidance on safety considerations for hydrogen systems (ISO, 2015) ⁽⁴⁴⁾. These guidances
2430 shall be observed when testing WE stacks ⁽⁴⁵⁾. IEC also published standards on FC safety (IEC, 2019a, IEC,
2431 2020b), which shall be applied by analogy. Additionally, IEC published guidance on the classification of areas
2432 where explosive atmospheres can occur (IEC, 2014a, IEC, 2013, IEC, 2017a, IEC, 2020a), which shall also be
2433 observed.

2434 In the European Economic Area (EEA) ⁽⁴⁶⁾, the ATEX Directives 2014/34/EU (EP and Council, 2014b) and
2435 94/9/EC (EP and Council, 1994) apply ⁽⁴⁷⁾. In addition, other EU legislation like the electromagnetic compatibility
2436 (EMC) Directive 2014/30/EU (EP and Council, 2014a) ⁽⁴⁸⁾, the Low-Voltage Directive (LVD) 2014/35/EU (EP and
2437 Council, 2014c) ⁽⁴⁹⁾, the general product safety Directive 2001/95/EC (EP and Council, 2001) ⁽⁵⁰⁾, the machinery
2438 Directive 2006/42/EC (EP and Council, 2006) ⁽⁵¹⁾ and the Pressure Equipment Directive (PED) 2014/68/EU (EP
2439 and Council, 2014d) ⁽⁵²⁾ apply. In principle, test items which do not conform to EU legislation shall not be used
2440 within the EEA.

⁽⁴⁴⁾ WG 29 of TC 197 currently reviews ISO/TR 15916:2015.

⁽⁴⁵⁾ WG 34 of TC 197 currently prepares the AWI entitled "ISO 22734-1 Hydrogen generators using water electrolysis - Industrial, commercial, and residential applications — Part 1: General requirements, test protocols and safety requirements".

⁽⁴⁶⁾ It comprises the EU territory according to Article 52 of the Treaty on European Union (TEU) and Article 355 of the Treaty on the Functioning of the European Union (TFEU), Iceland, Norway and Liechtenstein. It also applies to Switzerland under a mutual recognition agreement and Türkiye under a customs union agreement with the EU.

⁽⁴⁷⁾ The EC publishes guidance online at https://single-market-economy.ec.europa.eu/single-market/european-standards/harmonised-standards/equipment-explosive-atmospheres-atex_en.

⁽⁴⁸⁾ The EC publishes guidance online at https://single-market-economy.ec.europa.eu/sectors/electrical-and-electronic-engineering-industries-eei/electromagnetic-compatibility-emc-directive_en.

⁽⁴⁹⁾ The EC publishes guidance online at https://single-market-economy.ec.europa.eu/sectors/electrical-and-electronic-engineering-industries-eei/low-voltage-directive-lvd_en.

⁽⁵⁰⁾ The EC publishes guidance online at https://single-market-economy.ec.europa.eu/single-market/european-standards/harmonised-standards/general-product-safety_en.

⁽⁵¹⁾ The EC publishes guidance online at https://single-market-economy.ec.europa.eu/sectors/mechanical-engineering/machinery_en.

⁽⁵²⁾ The EC publishes guidance online at https://single-market-economy.ec.europa.eu/sectors/pressure-equipment-and-gas-appliances/pressure-equipment-sector/pressure-equipment-directive_en.

2441 **Annex B Test report**

2442 **B.1 General**

2443 The test report shall accurately, clearly and objectively present all relevant information to demonstrate the
2444 purpose(s) and objective(s) of the test. As a minimum requirement, the test report shall contain a title page
2445 (section B.2) and a summary (section B.3) with the measured or calculated TIPs and TOPs at least as mean
2446 values along with their (combined) standard uncertainties, whether absolute, relative or both. The test plan
2447 (section 6.6) forms part of the report. Calibration records or certificates of the measuring instruments shall be
2448 documented in the report and shall be available upon request.

2449 **B.2 Title page**

2450 The titlepage(s) shall present the following information:

- 2451 (a) Report identification, *i. e.* report number (optional),
- 2452 (b) Type of report (summary, detailed or full),
- 2453 (c) A reference to this document,
- 2454 (d) Author(s) of the report,
- 2455 (e) Entity issuing the report with name and address,
- 2456 (f) Date of the report,
- 2457 (g) Person(s) conducting the test when different from the reporting author(s),
- 2458 (h) Organisation conducting the test when different from report issuing entity,
- 2459 (i) Date and time per test run,
- 2460 (j) Location per test run when different from the address of the report issuing entity,
- 2461 (k) Descriptive name per test and
- 2462 (l) Identification (model name, serial number, type and specification) of the WE stack tested (including
2463 manufacturer).

2464 The titlepage(s) may be followed by a contents page before the summary report.

2465 **B.3 Summary**

2466 The summary shall include the following information:

- 2467 (i) test purpose(s) and objective(s),
- 2468 (ii) description of the test(s) with sufficient information on the test conduct and measurement set-up with
2469 test methods, measurement techniques (section 6.2) and test conditions (section 6.3),
- 2470 (iii) all relevant test parameters, namely TIPs and TOPs with uncertainties (section 7) and
- 2471 (iv) conclusion(s) with remark(s) and/or observation(s) as appropriate. Unless a full test report is to be issued
2472 where all test results shall also be presented graphically (section 7) and properly discussed, a brief
2473 discussion with graphical presentation of the main test results (section 7) supporting the conclusion(s)
2474 may be appended to the report.

GETTING IN TOUCH WITH THE EU

In person

All over the European Union there are hundreds of Europe Direct centres. You can find the address of the centre nearest you online (european-union.europa.eu/contact-eu/meet-us_en).

On the phone or in writing

Europe Direct is a service that answers your questions about the European Union. You can contact this service:

- by freephone: 00 800 6 7 8 9 10 11 (certain operators may charge for these calls),
- at the following standard number: +32 22999696,
- via the following form: european-union.europa.eu/contact-eu/write-us_en.

FINDING INFORMATION ABOUT THE EU

Online

Information about the European Union in all the official languages of the EU is available on the Europa website (european-union.europa.eu).

EU publications

You can view or order EU publications at op.europa.eu/en/publications. Multiple copies of free publications can be obtained by contacting Europe Direct or your local documentation centre (european-union.europa.eu/contact-eu/meet-us_en).

EU law and related documents

For access to legal information from the EU, including all EU law since 1951 in all the official language versions, go to EUR-Lex (eur-lex.europa.eu).

Open data from the EU

The portal data.europa.eu provides access to open datasets from the EU institutions, bodies and agencies. These can be downloaded and reused for free, for both commercial and non-commercial purposes. The portal also provides access to a wealth of datasets from European countries.

Science for policy

The Joint Research Centre (JRC) provides independent, evidence-based knowledge and science, supporting EU policies to positively impact society



EU Science Hub

joint-research-centre.ec.europa.eu



@EU_ScienceHub



EU Science Hub - Joint Research Centre



EU Science, Research and Innovation



EU Science Hub



@eu_science

